

VL6™

spot luminaire



The VARI*LITE® VL6™ spot luminaire uses the Philips MSR 400W short arc lamp in a cold mirror reflector. The luminaire is small, lightweight, and virtually silent.

Two wheels for interchangeable dichroic color and gobo selections, and three available lenses make the luminaire completely user-configurable. The VL6 supports a wide variety of "rental access" colors and gobos. "Purchase only" and custom gobos are also available.

The VL6 luminaire can be controlled from any VARI*LITE console, or can be controlled from a wide variety of DMX consoles.

Description

SOURCE:	Philips MSR 400 SA, 400W, 6000°K.
POWER AND DIMMING REQUIREMENTS:	Lamp power from the APS6™ module in the Modular Power Distribution Rack at 85 to 265 VAC, 50/60 Hz, 2.5 to 5A depending on line voltage. Luminaires are powered through the Smart Repeater™ processing unit.
REFLECTOR:	Precision glass reflector with dichroic cold mirror coating. The source may be adjusted in the reflector to peak or flatten the projected beam field.
LENS:	Standard is NFOV. Optional MFOV and WFOV lenses are available.
OPERATIONAL TEMPERATURE:	-20° to 120°F (-29° to 49°C).
COOLING:	Forced air.
CONTROL:	Completely compatible with either the VARI*LITE automated lighting system, featuring the Artisan®Plus or mini-Artisan®2 control console, or consoles with DMX-512 output.
MOUNTING POSITION:	The VL6 spot luminaire can be mounted and operated in any orientation.
SPACING:	Hangs 16.5 in. (419 mm) centers.
WEIGHT:	22 lbs (10 kg).

Programmable Functions

INTENSITY CONTROL:	Full field dimming designed for both smooth timed fades and strobe effects.
COLOR AND GOBO WHEELS:	Two rotating wheels, each providing eleven easily loaded positions for user-selectable color and gobo choices.
EDGE AND PATTERN FOCUS:	Variable beam focus to soften edges of gobos or spots.
BEAM SIZE CONTROL:	A mechanical iris provides continuous beam size control for both rapid changes and smooth timed beam angle changes.
PAN AND TILT:	Smooth, time controlled continuous motion by way of a digital servo system.
RANGE:	Pan - 360°, Tilt - 270°.
MAX VELOCITY:	240° per second.
ACCURACY:	0.3° resolution.

Accessories

71.2528.0400	400W Short Arc Lamp
22.9630.0081	Standard Lens (NFOV)
28.9638.0250	Optional MFOV Lens Kit
21.9638.0191	Optional WFOV Lens Kit
22.9634.0217	Series 300™ Truss Hook
22.9634.0145	Series 300 Safety Cable
22.9634.0161	Series 300 Floor Stand
25.7040.0006	6 ft. Shielded Series 300 Lamp Cable
25.7040.0012	12 ft. Shielded Series 300 Lamp Cable
25.7040.0020	20 ft. Shielded Series 300 Lamp Cable
25.7040.0050	50 ft. Shielded Series 300 Lamp Cable
25.7040.0100	100 ft. Shielded Series 300 Lamp Cable
25.7040.XXX	Custom Length Shielded Series 300 Lamp Cable*
	*Cannot exceed 300 ft. in length.
20.9625.0018	Series 300 Molded Plastic Six Luminaire Case
20.9625.0024	Series 300 Molded Plastic Work Trunk
22.5011.0063	Spare Components Set
22.5011.0067	Spare Assemblies Set

VL6 spot luminaire

Specifications

The unit shall be an integrally designed, remote controlled motorized spot luminaire. The housing and yoke shall be constructed of aluminum alloy and steel for lightweight strength and shall be forced-air cooled using two virtually silent fans. The rear lamp cap shall be removable, providing ease of access to the lamp for replacement and beam field adjustment.

Two enclosed, high torque servomotors shall be provided to permit movement of the head on a horizontal plane of 360° and on a vertical plane of 270°. Control cabling shall be run internally to prevent tangling. The low voltage motors shall be belt driven, providing positional resolution and repeatability of 0.3° on either axis. Manual override under power shall result in no harm to the drive mechanism.

Each unit shall be equipped with an on-board microprocessor providing diagnostic and self-calibration functions. In the event the luminaire encounters any physical obstruction during calibration, the pan and tilt motors will automatically be disabled preventing damage to the mechanisms.

The unit shall contain two rotating, easily removable filter wheels. Each wheel shall be capable of holding up to eleven, easily changeable, user-selectable dichroic color or gobo choices. Gobos shall be easily removable from unit, without the need to power down or lower the lighting system. Two motors provide independent drive regardless of direction of movement. Positional accuracy of the filter frame in reference to the beam shall be ensured by the microprocessor, which maintains count of both stepper motors and optical sensors that defines the open white positions. Wheels may also spin continuously.

The unit shall contain an aluminum bladed dimmer mechanism that provides full field dimming and allows for smooth timed fades and fast blackouts. A mechanical iris shall provide continuous beam size control for both rapid changes and smooth timed beam angle changes. Variable beam focus shall be provided to soften edges of gobos or spots and provide gobo crossfades. Three easily removable lenses shall be available for luminaire: narrow field of view (NFOV), medium field (MFOV), and wide-field (WFOV) lens.

Control cable to luminaire shall provide both digital control signal and power from power supply box. A safety cable shall be provided with unit, and a floor stand shall be available. Exterior finish shall be black epoxy coat. Total weight shall not exceed 22 lbs (10 kg). The unit shall be UL and C-UL listed and CE-marked.

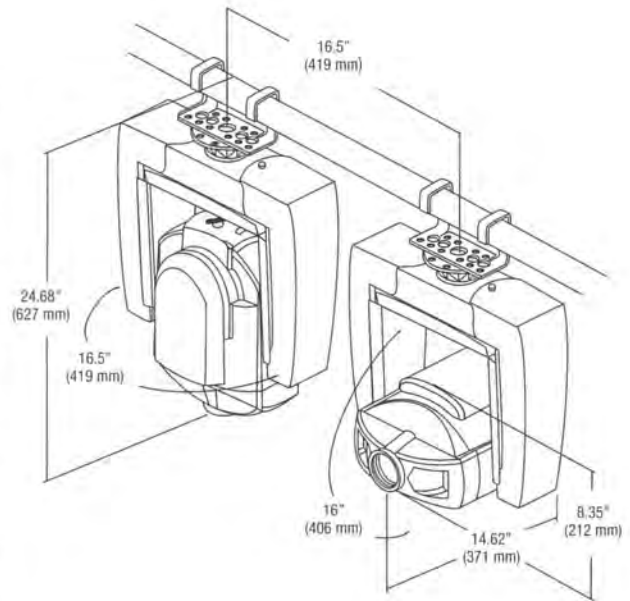

Photometric Data

VL6 Wash Luminaire - 400W Metal Halide						
LENS	DIFFUSION	CANDELA (cd)	BEAM ANGLE (DEGREES)	BEAM DIAMETER TN ¹	FIELD ANGLE (DEGREES)	FIELD DIAMETER TN ¹
NFOV (Peak Field)	Spot	520,000	6	.10	15	.25
	Flood	344,000	8	.13	17	.30
NFOV (Flat Field)	Spot	256,000	10	.17	18	.32
	Flood	128,000	14	.24	19	.33
MFOV (Peak Field)	Spot	216,064	8	.13	21	.37
	Flood	165,120	10	.17	23	.41
MFOV (Flat Field)	Spot	109,312	11	.19	22	.39
	Flood	46,272	14	.24	24	.42
WFOV (Peak Field)	Spot	91,520	12	.21	35	.63
	Flood	70,400	15	.25	36	.65
WFOV (Flat Field)	Spot	42,240	19	.33	41	.74
	Flood	23,616	27	.48	48	.89

¹ Multiply distance by Tn to determine coverage.

To calculate Illuminance (I) at a specific distance (D): $I = \frac{cd}{D^2} (\cos \theta)$