

SILHOUETTE 1000 'REPertoire'

The most versatile profile spot luminaire in a demanding industry



**NO SCREWS
NO BOLTS
NO FUSS**

**THE CASSETTE LENS TUBES SIMPLY SLOT
INTO POSITION WITHOUT DE-RIGGING**

A selection of four lens tubes equipped with the Silhouette variable beam facility offering a range of beam angles between 12° and 47° with hard or soft edge.



CCT

REPERTOIRE at the NATIONAL

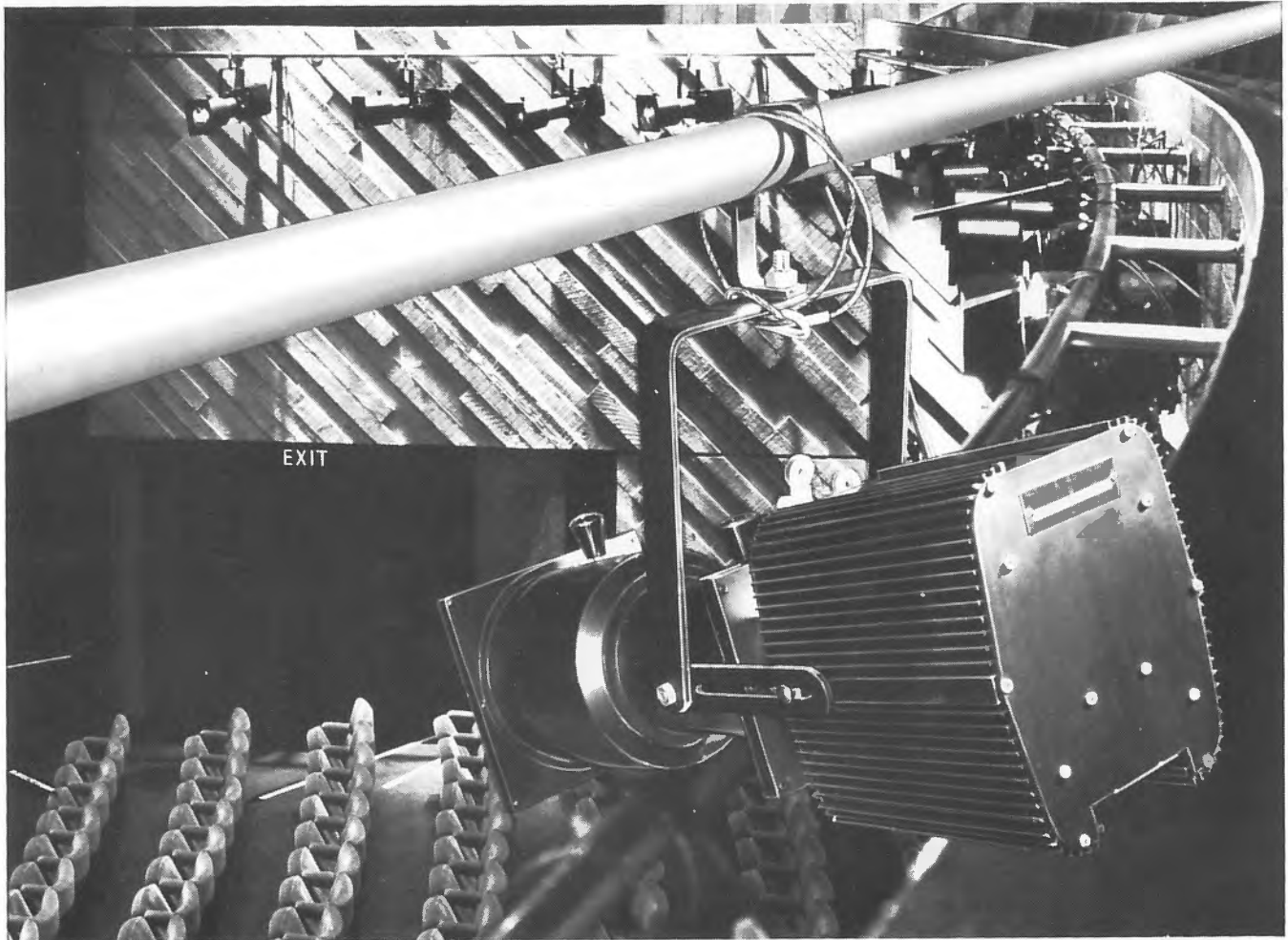

Repertoire Silhouettes installed at the Lyttelton Theatre, South Bank.

The Silhouette 'Repertoire' is a light portable luminaire ideally suitable for use as a touring lantern where the variable beam facility adapts easily to the different lengths of throw in any new venue situation.

The quick-change lens tubes may be mounted in the conventional manner with the lens slide controls beneath the lantern or easily reversed for access to the focus controls from above.

The shutter sets provided are lockable and will allow pre-set beam shaping or removal for storing.

A useful accessory is the drop-in Iris, slotting into the gate to reduce the beam to a pin-spot or together with a rear handle, converting the luminaire into an economical follow-spot, the gate will also accept a Gobo to project a sharply defined image of a selected subject.

The sturdy colour frame runners mounted on the front of the lens tube are double ended for reversal and will accept two DIN standard book form colour filter frames, lugged to prevent sliding through the open ended runners.

The lens tubes are safely secured by a spring clip in the cassette mounted on the lamp housing and may be quickly changed in the rigged position.

The Silhouette 'Repertoire' is 1.4 Kg heavier than the conventional version.

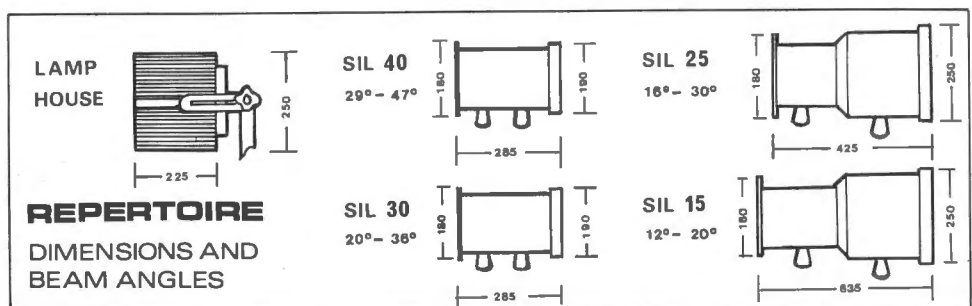

theatre lighting limited

11 MANOR ROAD WALLINGTON SURREY SM6 0BW TELEPHONE: 669 3167/7711 TELEX: 646648