

765

1000W C.S.I./C.I.D. Follow Spot 220/240V 50Hz

This Follow Spot is specially designed to use the robust, single-ended 1000W compact source discharge lamp which is between three and four times more efficient than a tungsten halogen filament lamp. This superior light source complete with the efficient reflector collection and large diameter lenses ensures that the model 765 provides exceptional performance.

This luminaire is fully equipped for ease of operation with adjustments for optimum balance and with all the beam-shaping facilities essential for a Follow Spot including a built-in, side-operated iris diaphragm and blackout disc, and both horizontal and vertical stripping shutters – a convenience notably absent from some others which are mere adaptations of Profile Spots with four push shutters.

There is now a choice of single-ended compact source lamps – the original C.S.I. with a colour temperature of 4100°K which tones in with tungsten lighting, and the relatively new Compact Source Daylight (C.I.D.) lamps with a much higher colour temperature of 5500°K nominal. The C.I.D. lamp has a lower lumen output but, to the human eye, appears to be much brighter and whiter due to colour contrast with tungsten lighting.

Order Codes

Model 765 1000W CSI/CID Follow Spot (incl. external regulation unit)	21 051 04
Folding, braced stand, for TV spigot	26 897 04
1000W C.S.I. 4100°K lamp, G.22 base 90,000 lm, 500 hr. obj. life	34 213 07
1000W C.I.D. 5500°K lamp, G.22 base 70,000 lm, 500 hr. obj. life	34 227 06



Rank Strand

21 051 04

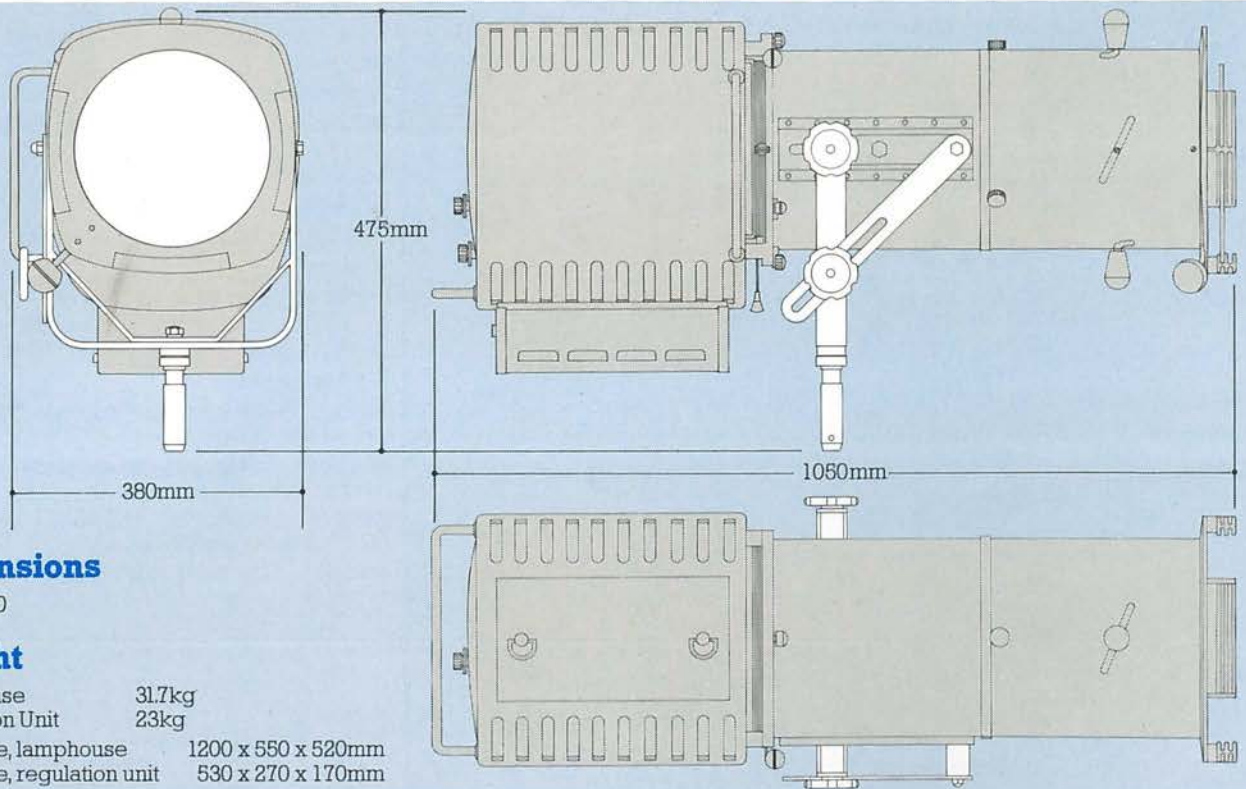

Dimensions

Scale 1:10

Weight

Lamphouse	31.7kg
Regulation Unit	23kg
Crate size, lamphouse	1200 x 550 x 520mm
Crate size, regulation unit	530 x 270 x 170mm



Rank Strand 765

Performance

Typical performance based upon 1000W C.S.I. lamp, 4100°K, 90,000 lm, 500 hour

Cut-off angle 14°

½ peak angle 11°

770,000 peak candela (cd)

With 1000W C.I.D. lamp, 5,500°K 70,000 lm, 500 hr peak intensity reduced to 600,000 cd, but when superimposed upon tungsten lighting appears brighter due to colour contrast.

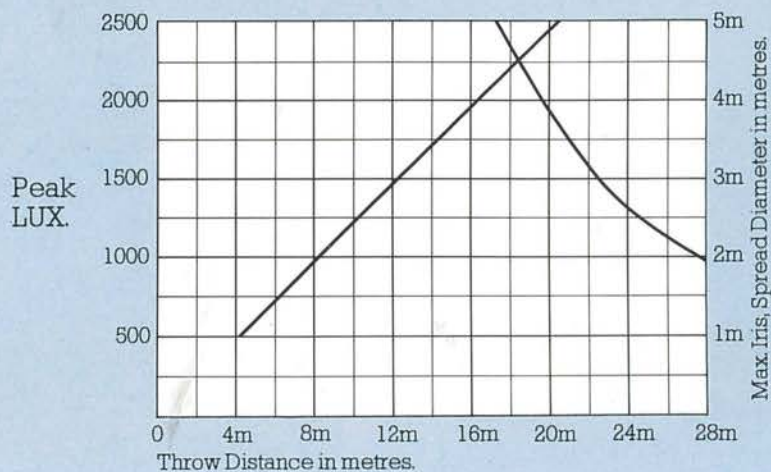
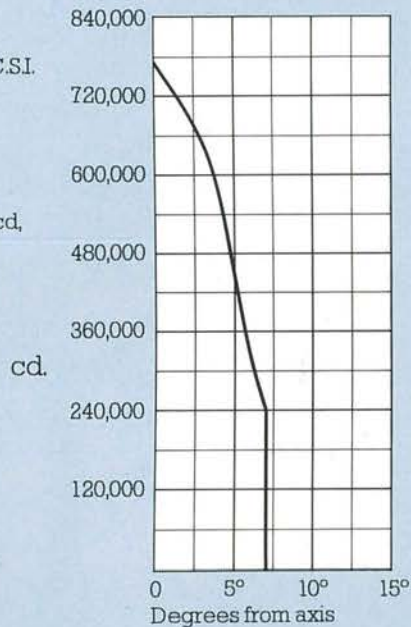

The company reserves the right to make any variation in design or construction to the equipment described.

Specification

Lamphouse

Zinc-coated, deep drawn steel pressings. Removable top, for interior access, secured by two captive fasteners. Handles at rear, side and on rigid lens front.

Mounting

Steel fork with special TV spigot for swivel and tilt clamp handwheel for slotted locking bar. Tilt pivot axis position adjustable laterally to allow balance to be maintained when accessory added to lens front.

Lampholder

Special EHT G.22 medium bipost mounted along optical axis.

Control Gear

All EHT starting circuitry contained within lamphouse including on/off switch, cartridge fuse, earth/ground continuity indicator and starting switch. 3 metres external length of 3-conductor cable fitted for 220/250V 50Hz supply. External compact regulation unit supplied has fixed connector to link with 2m long loop cable and mating connector from lamphouse.

Reflector

210mm diameter conic section near-ellipsoidal of polished anodised aluminium.

Gate Assembly

Built-in 18-leaf iris diaphragm with blackout disc with optional engagement at smallest iris aperture. Pair of horizontal and pair of vertical strip shutters each mechanically linked for parallel movement by a heat-resisting knob. Strip shutter assembly rotatable through 30° around optical axis to compensate for off-centre projection.

Lens

Twin 250 x 1015mm plano-convex, mounted in internal lens tube sliding helically in four slots in the fixed outer tube, moved and locked by two heat-resisting knobs. Outer tube constructed in two sections, for internal access, joined by an alloy casting.

Accessory Runners

Double 150mm long die-cast runners fitted to die-cast lens front, one 300mm square colour frame for 'Cinemoid' supplied.

Finish

High temperature stoved, powder-coated black.

Lamps

1000W max. G.22 base, 63.5mm l.c.l.
Compact Source Iodide (C.S.I.) 4100°K nom. or
Compact Iodide Daylight (C.I.D.) 5500°K nom.

Accessories

Folding, braced stand for TV spigot	26 897 04
Net weight 6.5kg	
Mechanical dimming shutter assembly (to fit front accessory runners)	23 740 06
Hand-operated 4-colour magazine (to fit front accessory runners)	23 636 07
Additional 'Cinemoid' colour frame	27 061 0T

Rank Strand
PO Box 51, Great West Road
Brentford, Middlesex TW8 9HR, United Kingdom
Telephone 01-568 9222. Telex 27976.