



OUTLOOK

Manual and Preset Lighting Control

Features:

- ❑ Simple network control wiring
- ❑ Each system can control up to 16 rooms
- ❑ 8 Preset scenes plus On and Off per room
- ❑ Manual sliders for direct control of individual circuits
- ❑ Choice of 3, 6, 9 or 12 control channels per room
- ❑ Record facility to store slider settings for future pushbutton recall
- ❑ LCD Display Station for custom preset labels
- ❑ 1, 4 and 8 Preset Remote Pushbutton station options
- ❑ Audio Visual Interface and Infra Red Remote Controls
- ❑ Programmable fade times of between 0 and 4 minutes
- ❑ Record Lockout facility for playback-only operation
- ❑ Room Combine Stations for room partitioning
- ❑ Portable station options
- ❑ Designed for use with Digital Environ, LD90, CD80SV and SLD dimmers
- ❑ Digital Network Interface available for using Outlook with other dimmers

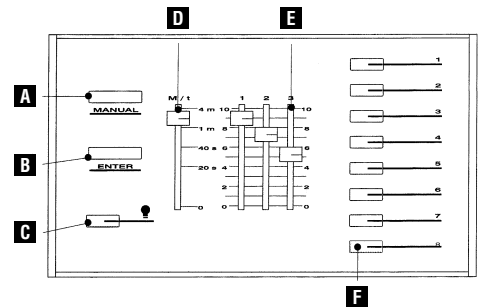

Outlook Master Station

- A Manual – Activates local sliders
- B Enter – Records slider settings into a preset
- C Off – Selects black-out
- D Master Slider – Overall control of slider levels and for setting fade times
- E Channel Sliders – Individual control of lighting levels
- F Preset Pushbuttons – For recall of 8 preset lighting scenes with fade times

Outlook Typical Schematic

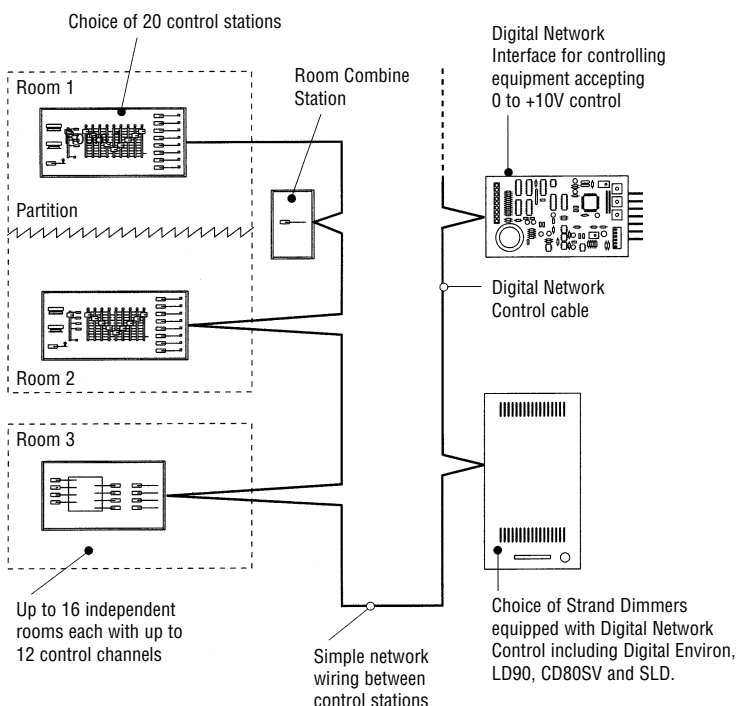

A Guide to Outlook

Outlook is a comprehensive family of control stations designed for architectural applications where a simple, flexible control solution with minimal installation and cabling cost is needed. Outlook is specifically designed for use with Strand Lighting Digital Environ™, LD90™, CD80SV™ and SLD dimmer cabinets.

The control stations access, modify and recall lighting levels stored in the dimmer cabinets via a common digital communication network cable without the need for an external central processor.

Control stations are available in various configurations and can be used in any combination to suit the user's requirements. During installation, an internal 16 position switch on the station determines the room to be controlled. Each of the possible 16 rooms can have up to 12 channels of control and 8 preset lighting scenes in addition to On and Off functions.

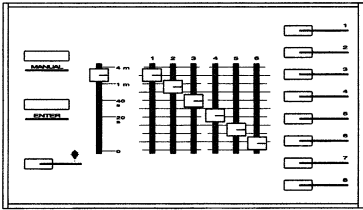

Master Stations

The Master Station is the most versatile station in the Outlook range combining the benefits of both preset and slider control.

Master Stations have 3, 6, 9 or 12 sliders plus proportional master, activated by a Manual button, providing full control of the lighting.

8 Preset pushbuttons enable the recall of 8 presets with programmable fade times up to 4 minutes. There is also the provision of an Off button.

An Enter button enables the slider settings and fade time to be recorded into a preset.

Master Stations provide the following additional functions:

- Record Lockout – to prevent unauthorized modification of presets from the local station
- Total Lockout – for disabling all other stations in the same room except the local station to prevent changes to the lighting.
- Preset Mastering – to proportionally master the level of a selected preset.
- Manual Fade Time – programmed for each room. When selecting Manual, the lighting fades to the levels set on the local sliders.
- Record Blind – to set up and record a preset lighting state from the manual slider settings without modifying the current lighting levels.

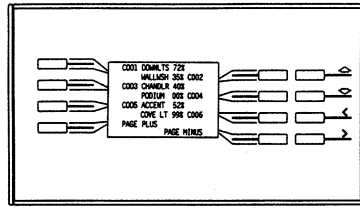

Display Station

The Outlook Display Station has 8 backlit LCD display used for labeling adjacent pushbutton functions.

The station has a “Set-up” or “Configuration” menu for selecting one of two* modes of operation during installation:

1. Preset Recall

Pushbuttons enable the recall of 8 labeled presets with programmed fade times. Raise and Lower buttons provide proportional mastering of the current preset, and an Off button fades lights off.

In this mode of operation, the Display Station provides the following additional functions:

- Custom label editing – 11 character labels for presets and 7 character labels for channels can be locally programmed.
- Channel level control – channel levels can be modified prior to recording a preset.
- Fade time programming – a fade time up to 4 minutes can be programmed for each preset.
- Record Lockout – to prevent local unauthorized modification of presets.
- Total Lockout – for disabling all other stations within the same room to prevent changes to the lighting.
- Clone – for copying labels to other Display Station in the same room to minimize programming.

2. Room Combination

Pushbuttons with custom room labels enable the user to combine, cancel and preview room combinations. Up and Down scroll buttons allow up to 16 rooms to be accessed.

In this mode of operation, the Display Station provides the following additional functions:

- Custom label editing – 11 character labels for rooms can be locally programmed.
- Clone – for copying room labels to other Display Station in this mode of operation to minimize programming.

A third operational mode configures the station for “System Wide Control” operation. Refer to the “System Wide Control” Datasheet for further information.

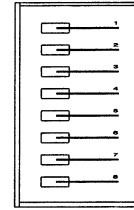

Remote Preset Stations

Preset Stations are available in versions with 1, 4 or 8 preset pushbuttons, for simple recall of pre-programmed lighting scenes within a room. Each pushbutton can be toggled to fade between its preset and Off.

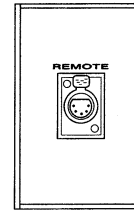

Receptacle Station

The Receptacle Station provides a socket to connect a portable Master, Remote Preset, or Slider Station to the communication network.

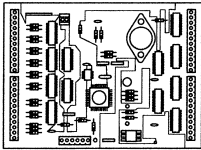

Audio Visual Interface

The A/V interface allows lighting presets to be selected automatically from external equipment such as slide projector controls, and sound systems. Each A/V Interface has 10 inputs with mimic outputs that accept a momentary contact closure to select one of the 8 presets, Off or On.

An additional input accepts a maintained contact closure to select the Total Lockout function (used to temporarily disable control from other stations within the room).

The A/V Interface is supplied as a printed circuit board for installation in equipment enclosures or with custom control panels. An external 18-24 volt dc power supply is required for the A/V Interface.

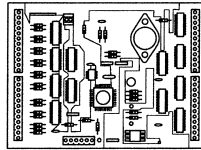

Room Combine Interface

The Room Combine Interface is supplied as a printed circuit board which can be used either:

1. With partition switches, to automatically combine rooms when partitions are moved.
2. With a custom control and mimic panel for manually selecting, cancelling and pre-viewing multiple combinations of rooms.

An external 18-24 volt dc power supply is required for the Room Combine Interface.

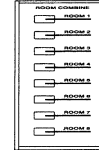

Room Combine Stations

Room Combine Stations for 2, 3 or 8 rooms, allow the user to combine, cancel and pre-view a combination.

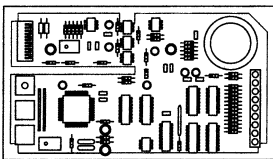

Digital Network Interface

The Digital Network Interface enables the Outlook range of control stations to be used with dimming systems that do not directly support Outlook's Digital Network Control protocol. Each interface provides the necessary support for Outlook stations and so may be used for stand alone operation. The interface provides 6 analog 0 to +10 volt dc outputs for controlling external equipment. Refer to the "Outlook Digital Network Interface" Data Sheet for further details and a full specification.

Dimming Options and Configuration with Outlook

Lighting Loads

Outlook Control Stations are designed for use with Digital Environ, LD90, CD80SV and SLD dimmer cabinets which have the capability of providing intensity control for tungsten, tungsten halogen, low voltage (transformer fed), fluorescent, neon and cold cathode lighting loads. Dimmers should be selected appropriate to the type of light source, load rating and the installation requirements. Alternative dimmers may be controlled from Outlook via the Digital Network Interface.

Strand Lighting Fact Sheets available include: "A Guide to Fluorescent Dimming" and "Dimming Transformer Fed Loads".

Note: Digital Environ and CD80SV are designed to North American standards, LD90 is designed to European standards. SLD meets all global standards.

Digital Environ, LD90, CD80SV and SLD Dimmers

Using the dimmer cabinet keypad and display during set-up, each individual dimmer circuit is assigned to a control channel in one of the possible 16 rooms.

A Power Supply (Part No. 66100 or 66101) is required when using Outlook control stations with LD90 dimmers.

Digital Environ has a power supply for up to 20 Outlook stations fitted as standard.

Room Combination

Ballroom and meeting areas in Hotels and Conference Centers often have the requirement to partition the space to create different combinations of rooms. For lighting control to accommodate partitioning of the space and provide both separate room control and control of combined areas, a Room Combine Station or Interface is also required. Refer also to the "Display Station" which can be used for room combination.



Faceplate Sizes

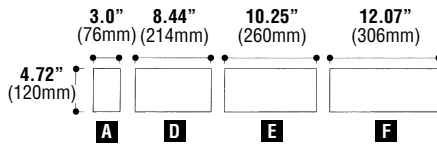

Faceplate Side Detail

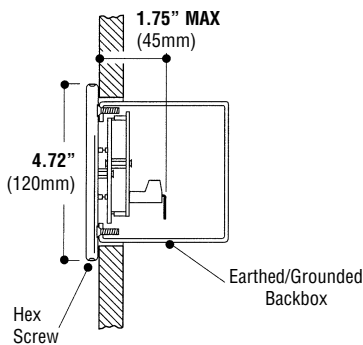

Supplementary Power Supply Unit

(Cat. No. 66100)

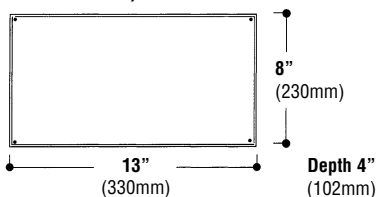

Back Box Sizes

All masonry back boxes are 3.5" (89mm) deep and all are 3.75" (95.3mm) high.

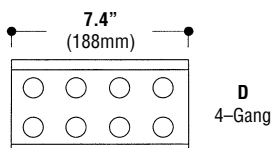

- A* 1-Gang 1.97" (50mm)
- D 4-Gang 7.4" (188mm)
- E 5-Gang 9.22" (234mm)
- F 6-Gang 11.03" (280mm)

Ordering Information

Cat. No.	Description	Faceplate/ Back box	Cat. No.	Description	Faceplate/ Back box
63003	Outlook – 3 Channel Master Station	D	66100	Outlook/Microcontrol Power Supply with Enclosure	–
63006	Outlook – 6 Channel Master Station	D	66101	Outlook (DIN Rail) Power Supply (LD90)	–
63009	Outlook – 9 Channel Master Station	E	66711	Portable Enclosure Kit (A-size)	–
63012	Outlook – 12 Channel Master Station	F	66714	Portable Enclosure Kit (D-size)	–
63030	Outlook – Display Station	D	66715	Portable Enclosure Kit (E-size)	–
63021	Outlook – 1 Preset Remote Station	A	66716	Portable Enclosure Kit (F-size)	–
63024	Outlook – 4 Preset Remote Station	A	66800	† 1-Gang Masonry Back Box (A-size)	–
63028	Outlook – 8 Preset Remote Station	A	66804	† 4-Gang Masonry Back Box (D-size)	–
63041	Outlook – Receptacle Station	A	66805	† 5-Gang Masonry Back Box (E-size)	–
63044	Outlook – Audio Visual Interface (excludes back box or custom enclosure)	–	66806	† 6-Gang Masonry Back Box (F-size)	–
63031	Outlook – 2 Room Combine Station	A	63040	Digital Network Interface	–
63033	Outlook – 3 Room Combine Station	A			
63038	Outlook – 8 Room Combine Station	A			
63039	Outlook – Room Combine Interface (excludes back box or custom enclosure)				

- Stations supplied with back box to order only.
- Bronze tinted Plexiglass locking covers are available to order for all Outlook Stations.
- † Portable Enclosure kits enable standard stations to be converted to portable units. Kits are supplied complete with 25ft (8m) cable and mating connectors.

*Note: Back boxes are subject to regional supply variations. Dimensions given are for guidance only and refer to Raco 690/960 series. Refer to your local Strand Representative for further details.

Strand Lighting Ltd

Unit 3 Hammersmith Studios, Yeldham Road,
Hammersmith, London W6 8JF United Kingdom
Tel: +44 (020) 8735 9790
Fax: +44 (020) 8735 9799

Strand Lighting GmbH

Ullsteinstrasse 114-142 D-12109
Berlin, Germany
Tel: +49 (0) 30/70 79 51 0
Fax: +49 (0) 30/70 79 519 9

Strand Lighting Italia srl

Via delle Gardenie 33 00040
Pomezia-Roma, Italy
Tel: +39 06 919631
Fax: +39 06 9147136

Strand Lighting Asia

20/F Delta House, 3 On Yiu Street
Shatin, N.T. Hong Kong
Tel: (852) 2757 3033
Fax: (852) 2757 1767



The Company reserves the right to make any variation in design or construction to the equipment described.
© Strand Lighting Ltd. 2002

Strand™, Strand Lighting™, Strand Quartzcolor™ are trademarks of Strand Lighting Limited and Strand Lighting Inc.