

DIMMEX™ w/Multi-Link™ (and/or Analog)

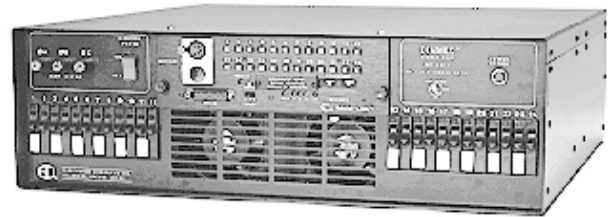

Dimmex 12-2



Dimmex 24-1

User Manual

Introduction

This User's Manual is supplied with your Dimmex. Copies of this manual may be obtained from Electronics Diversified, Inc., for a nominal charge. It is recommended that you copy those portions of this manual applicable to your present use in the installation, maintenance or repair and preserve the original in a safe place.

Copyright 1998, by Electronics diversified, Inc. All rights reserved.

No part of this Manual may be reproduced by any means, graphic, electronic, or mechanical, including photocopying, recording, taping, or information storage and retrieval systems, without the express written permission of Electronics Diversified, Inc., except in connection with installation, repair and maintenance of installed *Dimmex™ Dimmer Packs.

Table of Contents

Description	2
Front Panel	3
Rear Panel	4
Input Power Wiring	4
Three-Phase Wiring	4
Single-Phase Wiring	4
Input Control Connections	5
Analog Control	5
Analog Connector	5
Analog Wiring Connections	5
Multiplex Control	5
Dimmer Pack Address Table	5
*Multi-Link Connectors	6
USITT DMX-512 Digital Multiplex	6
USITT AMX-192 Analog Multiplex	6
*Fiber-Link Optical Multiplex	6
Multiplex Cables	6
Self Test	6
Dimmer Output Test	6
Lamp Preheat	6
Calibration	7
Wall Mounting	7
Dimmer Phasing Table	7
Solid-State Relay Replacement	8
Troubleshooting Guide	9
Service	9
Registration	10

Description

The Dimmex Multi-Link™ dimmer pack is a compact lighting control system providing twelve 2400 watt, or twenty-four 1200 watt, solid-state dimmers. With the Multi-Link control module, a variety of control formats are supported.

It is recommended that you read the following instructions before operating your dimmer pack for the first time.

Location: Although very efficient, solid-state dimmers generate heat . Be sure a free flow of air is allowed through the ventilation openings on the front and rear of the cabinet. Locate the dimmer pack close to the power source. Either avoid long power cable runs or increase the input power wire size.

Dimmer Type: This dimmer is designed to properly dim 120VAC incandescent or quartz lamps. Low voltage lamps operated through a standard (non-electronic) transformer with a 120VAC primary may also be operated. Do Not connect any other type of load such as motors or fluorescent lamps to this dimmer.

Power Source: This dimmer is designed to operate on 120 volts, 60Hz, AC power. This dimmer should be connected to a molded-case circuit breaker properly sized for the load.

Supply Cord: The dimmer power cord is not supplied. Refer to the INPUT Power Wiring section for proper wiring.



WARNING:

Maximum ambient operation and storage environment for this equipment is 104°F (40°C), with 90% humidity, non-condensing. Extreme caution is advised when having liquids, food and cigarettes around any equipment. During severe electrical storms, equipment should be disconnected. Failure to adhere to these requirements may result in malfunction or serious damage.

TO REDUCE THE RISK OF FIRE OR ELECTRICAL SHOCK, DO NOT EXPOSE THIS UNIT TO WET LOCATIONS.



CAUTION:

TO PREVENT THE RISK OF ELECTRICAL SHOCK. DO NOT REMOVE COVER. NO USER SERVICEABLE PARTS INSIDE. REFER SERVICING TO QUALIFIED SERVICE PERSONNEL.

Do not connect this Dimmer to other than the specified voltage, or to direct current.



Front Panel

1. **Input Power Error Indicator:**
This indicator will light if there is voltage between the neutral conductor and the dimmer chassis.
- IMPORTANT!**

If this indicator is on, disconnect power immediately and check for improper input power wiring. Refer to the INPUT POWER WIRING section.
2. **Dimmer Circuit Breakers:**
One fully magnetic circuit breaker is supplied for each dimming circuit. Turn off the corresponding breaker when re-lamping or connecting loads.
 3. **Control Power Switch:**
Turn on this switch to power the control electronics. When this switch is off, the dimmer will not respond to any external control signals and the dimmer preheat is off.
 4. **Power Indicators:**
These green indicators will light when power is applied to the corresponding phases. All three indicators should light on three-phase dimmers, and indicators 1 and 3 should light on single-phase dimmers.
 5. **Control Power Fuses:**
These three fuses protect the Multi-Link control module.
 6. **Dimmer Output Test Buttons & Status Indicators:**
Each yellow indicator will light as bright as the output of that individual dimmer. When the button is pressed in, the corresponding dimmer will be forced to full output and the yellow indicator will be at maximum brightness.
 7. **Analog Control Input:**
Connect the analog cable from an analog 0- +10 Volt controller here.

8. **Multiplex Signal Format Switch:**
Set this switch to "D" for USITT DMX-512 digital, or "A" for AMX-192 control formats.
9. **Dimmer Pack Number:**
These two thumbwheel switches select the dimmer pack address for multiplexed dimmer formats.
10. **Configure Button:**
This pushbutton is used to enter new multiplex data formats, self-test patterns, or different dimmer pack addresses. Press this pushbutton after any change is made in multiplex data formats, self-test patterns, or dimmer pack addresses.
11. **Multiplex control Input:**
Connect the multiplex cable from the control console here.
12. **Multiplex Control Output:**
This connector is paralleled to the Multiplex Control Input connector. Use this connector to add additional dimmers.
13. **Multiplex Signal Presence Indicator:**
The yellow indicator lights when a valid multiplex signal is received.
14. **Dimmer Overtemp Indicator:**
This red indicator will light when the dimmer pack is shut down due to an over-temperature condition. The dimmer pack will re-energize when it has cooled down to an acceptable temperature.
15. **Preheat Level:**
This control is used to set the preheat level of the lamps. Turn it clockwise to increase the preheat level.
16. **Calibration Access Plate:**
Removal of this plate allows access to calibration potentiometers and test points. Refer to Calibration section.

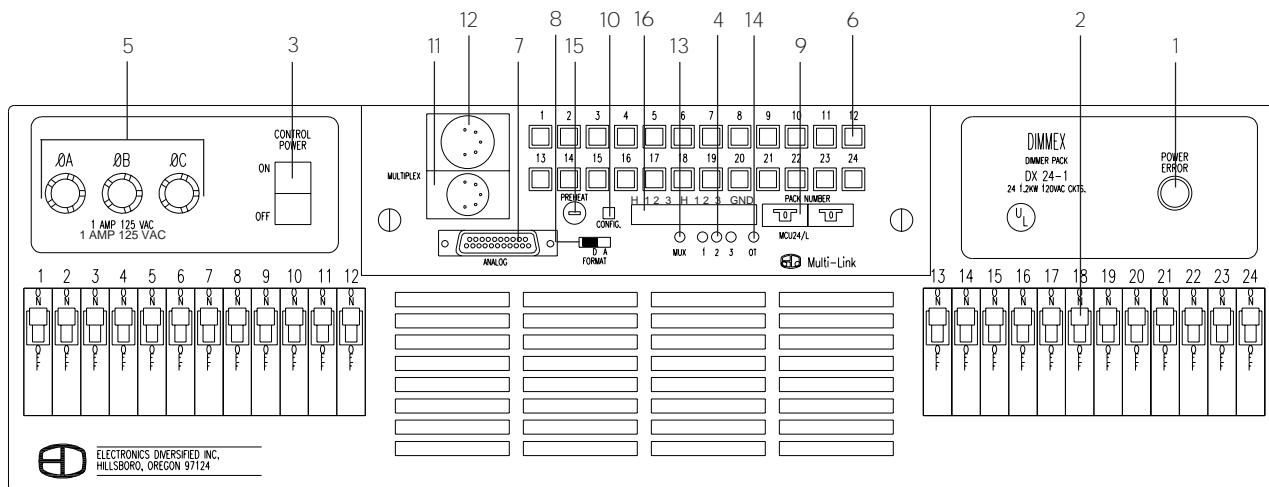

Rear Panel

1. Convenience Outlet:
External devices of up to 20 amps may be connected here.
2. Circuit Breaker:
This circuit breaker controls power to the convenience outlet.
3. Input Power Cable Clamp:
The input power cables are inserted here and secured by the clamp.
4. Dimmer Outputs:
Loads should be at least 25 watts.

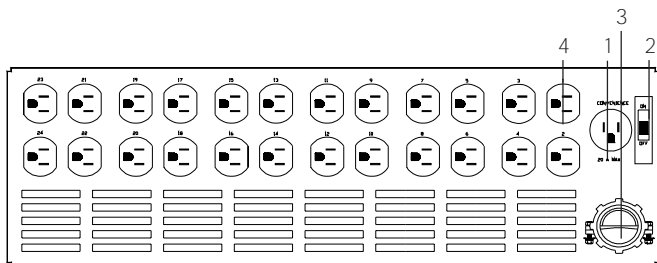

IMPORTANT!
Turn off the corresponding circuit breaker when re-lamping or connecting loads.

Input Power Wiring

It is strongly recommended that the input power wiring be installed by a qualified electrician.

This unit must be connected to a grounded power source! If a grounded power source is not available, contact a qualified electrician.

IMPORTANT!
Before connecting the input power, make sure the power source is *turned off*.
Set all breakers and the control power switch to the *off position*.
Unscrew and remove the dimmer cover. The line input terminal block is located on the right side of the dimmer.

Route the feed cable through the cable clamp and make the required connections to the terminal block and ground lug inside. Snug down all terminal and ground lug screws firmly, watching for stray wire strands which could cause shorts. Replace the cover and tighten the cable clamp.

The Dimmex Mult-Link dimmer can be operated on single- or three-phase power. Each is connected in a different way. Refer to the following instructions for proper connections.

IMPORTANT!
Solid-state dimmers are sensitive to resistance and the resulting voltage drops in the power feed cable. Excessive voltage drops may cause the dimmers to interact and flicker. This is especially true of the neutral conductor. The neutral conductor must be at least the same size as the line conductors. EDI recommends that the size of the neutral conductor be 125% of the line conductors.

Three-Phase Wiring -- 120/208 VAC

Three-phase wiring has three separate hot wires and a neutral.

1. Connect the Ground wire to the lug next to the terminal block. This unit must be grounded.
2. Connect the Neutral wire to the "N" terminal.
3. Connect the Phase A wire to the "Ø A" terminal. Connect the Phase B wire to the "Ø B" terminal. Connect the Phase C wire to the "Ø C" terminal.

IMPORTANT!
Do not connect this dimmer pack to Delta configuration three-phase power sources. The input power requirement for this unit is 80 amperes per phase.

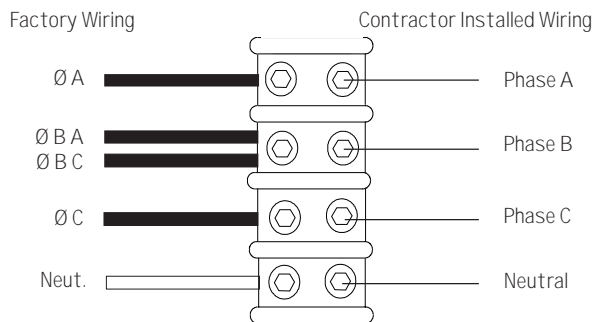

Double-check all connections, and make sure all terminals are tightly secured before replacing cover. Tighten the cable clamp and connect the cable to a suitable power source.

Apply power to the dimmer and check the Input Power Error Indicator. If it is on, the dimmer is miswired. Turn off power immediately and check the input power wiring.

Turn on the Control Power switch and check the three green power indicators. All three indicators should light.

Connect the loads and turn on all of the circuit breakers. The dimmer is now ready to use.

Single-Phase Wiring -- 120/240 VAC

Single-phase wiring has two separate hot wires and a neutral.

1. Connect the Ground wire to the lug next to the terminal block. This unit must be grounded.
2. Connect the Neutral wire to the "N" terminal.
3. Connect the hot wires to the Line 1 and Line 2 terminals.



Single-Phase Wiring -- 120/240 VAC (cont'd)

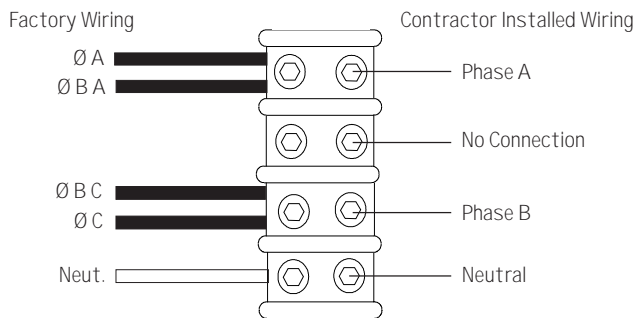

IMPORTANT!
 The dimmer pack is intended to be operated from a 120/240 VAC power source (2 hots and 1 neutral). Do not connect this dimmer to a single 120 volt power source (1 hot and 1 neutral).
 The single-phase input power requirement for this unit is 120 amperes per phase.

Double-check all connections and make sure all terminals are tightly secured before replacing cover. Tighten cable clamp and connect cable to power source.

Apply power to the dimmer and check the Input Power Error Indicator. If it is on, the dimmer is miswired. Turn off power immediately and check the input power wiring.

Turn on the Control Power switch and check the three green power indicators. Indicators 1 and 3 should light. Indicator 2 should be off.

Connect the loads and turn on all of the circuit breakers. The dimmer is now ready to use.

Input Control Connections

This dimmer may be controlled by either an analog output controller 0 - +10 volt D.C., or one of three multiplexed output controllers. The following sections describe all control formats.

Analog Control

This dimmer is equipped with a male 25-pin "D" connector for operation from 0 to +10 Volt D.C. analog control voltages.

1. Connect the analog cable to the analog input connector.
2. Set the pack address switches to 00 to disable the self-test and multiplex input features.
3. Press the **Configure** button.

NOTE: If you are using the analog and multiplex controls at the same time, ignore steps 2 and 3.

Analog Connector 25-pin D type

Female mating connector: Cannon #DB-25S

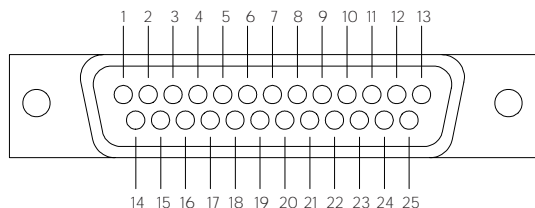

Analog Wiring Connections

Dimmer Number	Control Pin
1	1
2	2
3	3
4	4
5	5
6	6
7	7
8	8
9	9
10	10
11	11
12	12

Dimmer Number	Control Pin
13	13
14	14
15	15
16	16
17	17
18	18
19	19
20	20
21	21
22	22
23	23
24	24
Control Ground	25

Multiplex Control

The Multi-Link controller may be configured for different control formats. When using the multiplex control option, the dimmer "Pack Number" thumbwheels must be set to the proper value.

NOTE: Dimmer pack numbers are in groups of twelve. Pack number 01 is for dimmers 1-12, 02 is for dimmers 13-24, and so on.

Usually, the first dimmer pack (dimmers 1-12) is set to **01**, the second dimmer pack (dimmers 13-24) to **02**, and so on. On 24 dimmer models, each dimmer pack uses two numbers. The first pack should be set to **01** (dimmers 1-24), the second pack to **03** (dimmers 25-48), etc.

Table 1 gives the corresponding dimmer numbers for all valid dimmer pack addresses.

TABLE 1
Dimmer Pack Address Table
 (12- and 24- dimmer models)

Pack Address	Beginning Dimmer #	Pack Address	Beginning Dimmer #
00	NONE	22	253
01	1	23	265
02	13	24	277
03	25	25	289
04	37	26	301
05	49	27	313
06	61	28	325
07	73	29	337
08	85	30	349
09	97	31	361
10	109	32	373
11	121	33	385
12	133	34	397
13	145	35	409
14	157	36	421
15	169	37	433
16	181	38	445
17	193	39	457
18	205	40	469
19	217	41	481
20	229	42	493
21	241		

Whenever the dimmer pack number is changed, the **Configure** button must be pressed to enter the change.

If a pack is set to 00, the Multiplex signal is disabled.



Multi-Link Connectors

5-pin XLR type mating connectors:

Female connector
(to next dimmer pack)
Switchcraft No. A5F

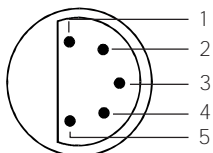

Male connector
(from console)
Switchcraft No. A5M

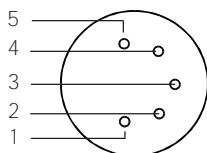

Wiring Connections:

- | | |
|------------------|---------------------|
| 1. Analog Ground | 4. Analog Multiplex |
| 2. Clock/Data - | 5. Overtemp |
| 3. Clock/Data + | |

USITT DMX-512 Digital Multiplex

The USITT DMX-512 Digital multiplex format will allow up to 512 dimmers to be controlled from a single cable. In addition to the digital signal, the Dimmex Multi-Link sends an overtemp signal to the control console in the event of an overtemp condition.

1. Set the multiplex signal format switch to **D** (for Digital multiplex).
2. Set the desired pack number (see Multiplex Control section).
3. Press the **Configure** button.
4. Connect a USITT DMX-512 compatible control cable from the control console to the multiplex control input connector.

USITT AMX-192 Analog Multiplex

The Multi-Link AMX-192 analog multiplex format will allow up to 192 dimmers to be controlled from a single cable.

1. Set the multiplex signal format switch to **A** (for Analog multiplex).
2. Set the desired pack number. The AMX-192 standard will only support 192 dimmers. The maximum pack address number that can be used is 16.
3. Press the **Configure** button.
4. Connect an AMX-192 adapter control cable from the control console to the multiplex control input connector.

Fiber-Link Optical Multiplex (Optional)

The Fiber-Link multiplex format will allow up to 512 dimmers to be controlled from a single fiber-optic cable.

1. Set the desired pack number (see Multiplex Control section).
2. Press the **Configure** button.
3. Connect a Fiber-Link multiplex cable from the control console to the fiber-optic receiver (labeled **IN**).
4. Additional dimmer packs may be daisy-chained by running a Fiber-Link multiplex cable from the fiber-optic transmitter (labeled **OUT**) to the fiber-optic receiver (labeled **IN**) on the next dimmer.

NOTE: If the control power switch is off, or power is disconnected to the dimmer pack, the Fiber-Link signal received at the IN connector will not be transmitted by the OUT connector.

In order to use the Fiber-Link multiplex format, an optional Fiber-Link module must be installed. This module has only fiber-optic connectors, not Multi-Link connectors. Therefore, Multi-Link and Fiber-Link dimmers may not be interchanged unless the control console has dual output.

Multiplex Cables

Standard Multi-Link Cable is used to connect the dimmer pack to USITT DMX-512 or Multi-Link compatible consoles. This cable is also used to interconnect packs for all multiplex formats.

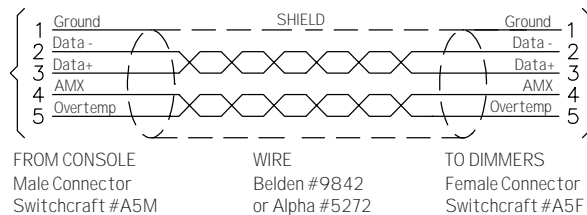

Strand CD 80 to Multi-Link Adapter Cable

Strand CD-80 to Multi-Link adapter cable is required for Strand consoles with smaller 4-pin MINI-XLR-type connectors. Use this adapter to connect the first dimmer pack to the console. Additional dimmer packs may be added by using standard Multi-Link cables.

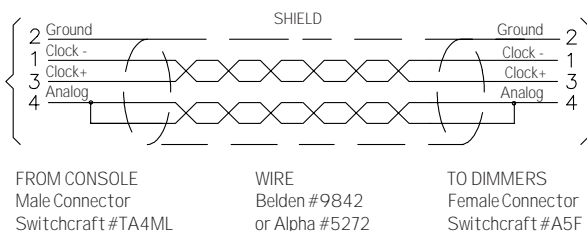

Self Test

The Multi-Link system has three built-in test patterns. The patterns are enabled by selecting dimmer pack numbers of 50, 60, and 70.

To enable a self-test pattern,

1. Select the desired pattern:
 - 50 - One dimmer on at a time.
 - 60 - Build (starts with dimmer 1 and adds on additional dimmers).
 - 70 - All dimmers on at once.
2. Press the **Configure** button. The self-test will start immediately. The right hand thumbwheel switch may be changed to vary the speed of the test.
 - 0** is the fastest, **9** is the slowest.

Dimmer Output Test

There is a yellow button on the front panel for each dimmer channel. Pressing it in will cause that dimmer to immediately go to full intensity. Pressing the button again will resume normal operation of that channel. The yellow indicator inside each test button shows the same percentage of brightness as the corresponding output.

Lamp Preheat

The lamp preheat adjustment allows a small amount of current flow through the lamp filaments at all times. This preheat (warming current) reduces the shock to the filaments when the lamps are suddenly turned on to full. Increasing the preheat level will significantly increase lamp life, especially in applications where the lamps are rapidly flashed on and off.



Lamp Preheat (cont'd)

Turn the lamp preheat clockwise to increase the lamp preheat and counter-clockwise to reduce it. For optimum preheat adjustment, turn the control all the way clockwise and then slowly turn it counter-clockwise until the lamps stop glowing.

Calibration

This dimmer has been factory calibrated and should never require additional calibration. Before calibration is attempted, make sure that all other equipment has been checked for failure or malfunction, especially the control console.

If the dimmer is ghosting (all lamps glowing), turn the preheat control counter-clockwise.

The Dimmex Multi-Link is designed to be calibrated for a 0- +10 volt analog control signal. If the dimmer is calibrated for other analog control levels, the digital formats (including the test modes) will not work properly.

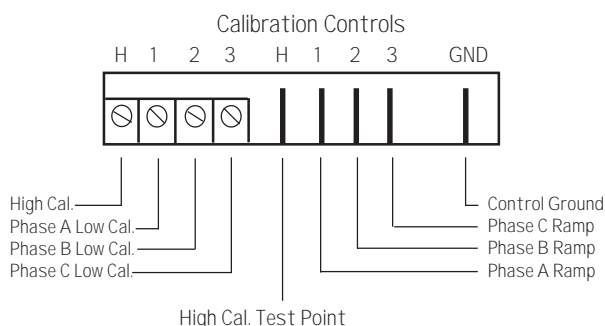

High End Calibration

Remove the calibration access plate. Connect a digital voltmeter between the test point labeled **H** (high cal.) and **GND**. Adjust the **H** calibration potentiometer so meter indicates exactly +9.3 volts.

Low End Calibration

Set the preheat control to ¼ of the way from full counter-clockwise. Connect identical 100-500 watt clear lamps to dimmers 1, 5, and 8 (on six-dimmer models, use 1, 3, 5; on 3-dimmer models, use 1, 2, and 3).

Adjust low cal. potentiometer **1** until the lamp connected to dimmer **1** barely glows.

Adjust low cal. potentiometer **2** until the lamp connected to dimmer **5** glows at the same intensity as the lamp connected to dimmer **1**.

Adjust low cal. potentiometer **3** until the lamp connected to dimmer **8** glows at the same intensity as the lamps connectd to dimmers **1** and **5**. Reset the preheat control for the desired preheat level.

The dimmer is now properly calibrated.

Wall Mounting

Mount the dimmer to the wall with the front panel facing either right or left as shown.

Allow 6" clearance on all sides, and 12" in front (circuit breaker) side to allow the dimmer control module to be removed. Do not block any of the ventilation openings.

Do not use aluminum wire.

Do not run the control wiring and the line (or load) wiring together or in the same conduits.

Avoid running common neutrals to the load wiring.

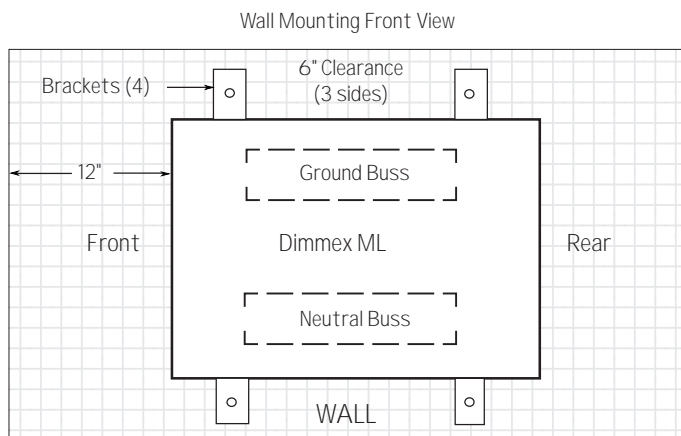

Wall Mounting (Side View)

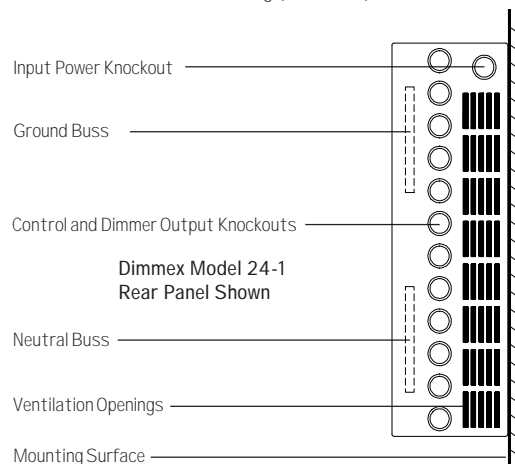

If common load neutrals absolutely must be run (retrofit situations), do not connect circuits of the same phase to the same common neutral wire. Do not run more than three dimmers (three-phase) or two dimmers (single-phase) on a common neutral wire. Choose the size of the neutral wire to handle 120% of the rated dimmer load.

Refer to Table 2 for normal dimmer phasing.

TABLE 2
Dimmer Phasing

Dimmer Number	Three-Phase	Single Phase	Dimmer Number	Three-Phase	Single Phase
1	Phase A	Line 1	13	Phase A	Line 1
2	Phase A	Line 1	14	Phase A	Line 1
3	Phase A	Line 1	15	Phase A	Line 1
4	Phase A	Line 1	16	Phase A	Line 1
5	Phase B	Line 1	17	Phase B	Line 1
6	Phase B	Line 1	18	Phase B	Line 1
7	Phase B	Line 2	19	Phase B	Line 2
8	Phase B	Line 2	20	Phase B	Line 2
9	Phase C	Line 2	21	Phase C	Line 2
10	Phase C	Line 2	22	Phase C	Line 2
11	Phase C	Line 2	23	Phase C	Line 2
12	Phase C	Line 2	24	Phase C	Line 2



Solid-State Relay Replacement

Determine which dimmer needs repairing. The solid-state relays are mounted on the heatsink.

1. Note the arrangement of the power connections (factory installed wires) on the defective solid-state relay, then unplug the connections.
2. Note the orientation of the control connector, then unplug the connector.
3. Remove the relay by removing the two screws which secure it to the heatsink.

4. Apply a thin coating of heatsink compound to the bottom of the new solid-state relay and replace by following steps 1-3 in reverse order.

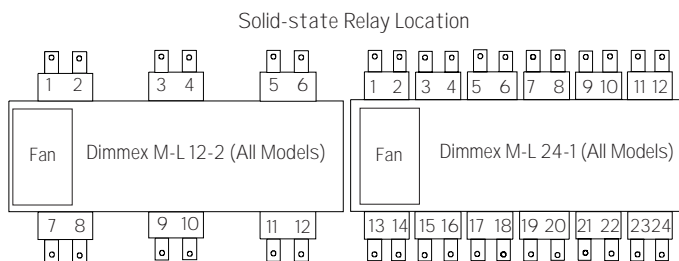

Troubleshooting Guide

Symptom	Possible Cause	Remedy
Nothing works, green indicators 1, 2, and 3 are dark.	Control power switch is off. Input power source is off.	Turn on control power switch. Check input power source.
Nothing works, green indicator 1 is dark, 2 and 3 are on.	Phase A (Line 1) fuse blown. Phase A (Line 1) power source off.	Replace fuse. Check input power source.
Dimmers 5, 6, 7 & 8 don't dim correctly, or snap on instead of dimming.	Phase B fuse blown. Phase B power source off. Single-phase dimmer pack wired to three-phase power.	Replace fuse. Check input power source. Connect dimmer to single-phase power source.
Green indicator 2 is off.	Three-phase dimmer pack wired to single-phase power.	Connect dimmer to three-phase power source.
Dimmers 9, 10, 11 or 12 don't dim correctly, or snap on instead of dimming.	Phase C (Line 2) fuse blown.	Replace fuse.
Green indicator 3 is off.	Phase C (Line 2) power source off.	Check input power source.
A dimmer channel is always on and the corresponding output status indicator is on.	Dimmer channel in test mode. Defective solid-state relay.	Depress the corresponding button to clear the test. Replace the solid-state relay.
A dimmer channel is always on and the corresponding output status indicator is off.	Defective solid-state relay.	Replace the solid-state relay.
A dimmer channel is always off and the corresponding output status indicator is off.	The solid-state relay control connector is loose, unplugged, or plugged in backwards. Defective solid-state relay.	Check control wiring connector to solid-state relays. Replace the solid-state relay.
A dimmer channel is always off, but the corresponding output status indicator operates properly.	Defective lamp fixture plugged into dimmer. Dimmer circuit breaker is off. Dimmer circuit breaker is tripped. Defective solid-state relay.	Check the load with a known good fixture. Turn on the circuit breaker. Reset the circuit breaker by turning off and then on. Replace the solid-state relay.
All of the lamps "ghost" (glow).	Lamp preheat set too high. Dimmer out of calibration.	Rotate the preheat control counterclockwise. Recalibrate the dimmer.
Lamps plugged into dimmers 1 - 4, or 5 - 8, or 9 - 12 ghost.	The corresponding phase low end calibration is out of adjustment.	Recalibrate the dimmer.
The multiplex signal indicator flashes, lamps flicker, or dimmers refuse to respond to multiplex signal.	Dimmer address set to 00. Bad multiplex cable. Multiplex format set to wrong setting.	Set the dimmer pack address to a valid number. Check the dimmer pack with a known good cable. Set the format switch to the proper format.

(cont'd)



Troubleshooting Guide (cont'd)

Lamps flash, flicker, or sequence.	Dimmer address set to test modes. (50-70) Bad multiplex cable. Multiplex format set to wrong setting.	Set the dimmer pack address to a valid number. Check the dimmer pack with a known good cable. Set the format switch to the proper format.
The dimmer pack overheats.	The cooling vents are blocked. The dimmer pack is full of dust. The dimmer is in a very warm location.	Clear any obstructions to the cooling vents. Carefully remove dust and dirt with compressed air or a vacuum cleaner. Relocate the dimmer to a cooler location.
Lamps go out before the console sliders reach zero.	The analog control console is not set for 0 - +10V output. The low-end calibration is out of adjustment.	Check the output from the console. Recalibrate the dimmer.
Lamps are on full before console sliders reach full.	The analog control console is not set for 0 - +10V output. The high-end calibration is out of adjustment.	Check the output from the console. Recalibrate the dimmer.
Input power error light on.	Faulty or incorrect input power wiring.	Do not touch the dimmer pack or anything connected to it. Check for voltage between the ground and neutral conductor. Disconnect the power source and check all input power wiring.

Service

EDI offers a 24 hour Service / Support Network.
 For technical questions about this product or operational assistance, ask for Customer Service at: 1-800-547-2690
 You may communicate by FAX: 1-503-629-9877
 After Hours Emergency contact: 1-503-645-5533
 Ask for Emergency Assistance.
 Internet: www.edionline.com
 Internet E-Mail: service@edi.online.com

If your Dimmex needs repair, call 503-645-5533 for a Return Materials Authorization number, and a **shipping address** will be furnished.



Electronics Diversified, Inc.
 1675 N.W. Cornelius Pass Road
 Hillsboro, Oregon, 97124
 Ph: (503) 645-5533 Fax: (503) 629-9877



Attention Dimmex M-L dimmer pack owners!

Please return this registration card immediately.

Your prompt attention to this matter will ensure your receiving updated technical information for this product as it becomes available. Please complete all information. Look for acknowledgment of your registration within 6-8 weeks.

Name: _____

Title: _____

Facility and/or Company: _____

Street Address: _____

City: _____ State: _____ Zip: _____

Phone: _____

Fax: _____

E-mail: _____

Web site: _____

CUT ALONG DOTTED LINE



Mail to:
EDI User Manual Registration
1675 NW Cornelius Pass Road
Hillsboro, Oregon 97124

or FAX to: (503) 629-9877

