



CONTROL STATION OPERATION WITH INFRARED REMOTE CONTROL

Preset Recall

To recall a preset from any station simply select the desired preset button and the station will playback the levels recorded for that scene. The Raise lower keys can then be used to master the entire preset proportionally raising and lower all of the levels. To restore to the recorded levels simply select the desired preset again.

Control Stations within the same room will automatically track each other. Selecting a preset from any station will take local control and select the desired preset.

Recording Presets

Each Accent station is supplied with a hand held infrared control unit. The Infrared remote control is used to program the Accent 2, 4 or 8-button control stations. The IR remote works by using a low frequency light beam. This beam is so low that the human eye cannot see it, but the IR receiver in the Accent control station can detect it.

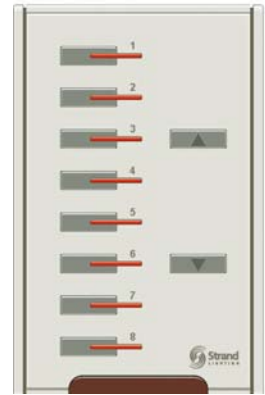

Typical Accent Control Station

Infrared Remote Operation

There are 8 dedicated scene pushbuttons (marked 1, 2, 3, 4, 5, 6, 7, 8). There are also raise & lower keys (marked ▲ for “raise” and ▼ for “lower”) on the center of the remote unit. Their function is identical to the raise & lower keys on the Accent control station. At the bottom is a command group of buttons (AND, CHAN, LEVEL, FADE, TO, RECORD, 1, 2, 3, 4, 5, 6, 7, 8) for manipulating channel levels and fade times.

To Enter Programming Mode

To enter programming mode, press and hold the ▲ and ▼ buttons simultaneously on the control station (not the ▲ and ▼ buttons on the infrared remote control) for approximately 3 seconds until all the control station scene LED's and IR LED start blinking. The blinking LED's indicate that the control station is now in programming mode. Release the ▲ and ▼ buttons. The LED's will stop flashing and turn off. The control station is now in programming mode.



Infrared Remote

Basic Button Syntax

Select the scene number button to be changed from the remote unit and then enter the new data in the following sequence:

CHAN, XX, TO (or AND), XX, LEVEL, YY, FADE, ZZ, RECORD

Please note that **XX** and **ZZ** can be either single or double digits (Channel 1 can be entered as 01 or just 1), but **YY** must be entered as double digits (a 9% level must be entered as 09).

Example 1 – Recording A Scene

This example will record scene 1 to contain channel 1 and 47 at a 55% level with a 5 second fade time.

Press the scene 1 button on the top of the remote control to select scene 1 (please note that the LED for scene 1 will blink continuously), followed by: CHAN, 1, AND, 4, 7, LEVEL, 5, 5, FADE, 5, RECORD

Example 2 – Modifying A Channel Level Via The Command Pad.

This example will change channels 5 through 10 to a 0% level without changing the fade time on Scene 4.

Press the scene 4 button on the top of the remote control to select scene 4 (please note that the LED for scene 4 will blink continuously), followed by: CHAN, 5, TO, 10, LEVEL, 0, 0, RECORD

Example 3 – Modifying A Channel Level Via the ▲ and ▼ buttons.

This example will adjust the level of channel 3 & 7 in scene 4.

Press the scene 4 button on the top of the remote control to select scene 4 (please note that the LED for scene 4 will blink continuously), and then press CHAN, 3, AND, 7 and either the ▲ or ▼ level keys until they reach the desired level, then press RECORD.

Example 4– Setting A Fade Time

This example will set the fade time to 10 seconds (the default time for Accent is 3 seconds) on scene 2.

Press the scene 2 button on the top of the remote to select scene 2 (please note that the LED for scene 2 will blink), follow by: FADE, 1, 0, RECORD

Exiting Program Mode

To exit programming mode, press and hold the ▲ and ▼ buttons simultaneously on the control station (not the ▲ and ▼ buttons on the infrared remote control) for approximately 3 seconds until all the control station scene LED's and IR LED start blinking. Then release the ▲ and ▼ buttons. When the station resumes normal operation all LED's will be off, however the last programmed scene (even without a record operation) will still be live. Select any preset from either the control station or the infrared remote control.



ACCENT 2, 4 and 8 BUTTON STATION REAR VIEW

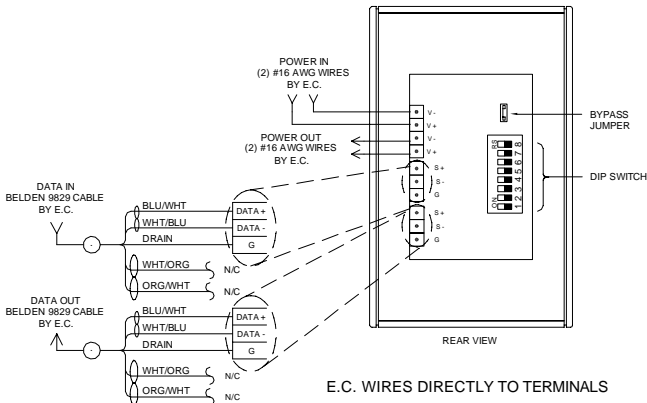

For ease of installation each Accent control station uses separate terminals for input and output daisy chain wiring. There is no need to install multiple conductors under the same terminal block, unless you are utilizing CAT5 cabling.

The BYPASS JUMPER (located at J1) should always be installed. Removing the bypass jumper disables the station in the control chain.

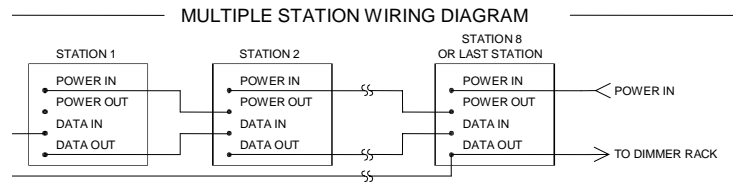

Important Note: In order for proper station operation, please be sure that the data in and out pairs “swap” between stations. This will maintain the proper transmit and receive connections required for inter-station communication.

Additionally, a cable must “loop” back from the last station in the chain, to the first station in the chain. This is required for inter-station communication.

Station Switch Settings

Station ID Selection

Station ID	Switch 5	Switch 6	Switch 7
0	OFF	OFF	OFF
1	ON	OFF	OFF
2	OFF	ON	OFF
3	ON	ON	OFF
4	OFF	OFF	ON
5	ON	OFF	ON
6	OFF	ON	ON
7	ON	ON	ON

Station DMX Range addressing

Room #	Switch 1	Switch 2	Switch 3	Switch 4	Channels	DMX512
1	ON	OFF	OFF	OFF	1-48	1-48
2	OFF	ON	OFF	OFF	1-48	49-96
3	ON	ON	OFF	OFF	1-48	97-144
4	OFF	OFF	ON	OFF	1-48	145-192
5	ON	OFF	ON	OFF	1-48	193-240
6	OFF	ON	ON	OFF	1-48	241-288
7	ON	ON	ON	OFF	1-48	289-336
8	OFF	OFF	OFF	ON	1-48	337-384

For additional information including a full manual for this product, , service or support contact your nearest Strand Lighting office or service center. This information is available at www.strandlighting.com.

