



PROFESSIONAL SHOW LIGHTING

TORNADO

HMI 575

INSTRUCTION MANUAL

IMPORTANT: Read carefully. It is essential for the correct and safe use of the equipment that erectors and operators should be fully conversant with the information and instructions given in this manual.

1 INSTALLING THE PROJECTOR

• Unpacking

Open the wooden box, unscrew the two transport screws (1), remove the projector from the packing and place it on a flat horizontal surface.

Unpack the standard accessories supplied with the fixture.

Inspect the lamp change label (2) and replace it with one of the optional language versions if necessary.

Make certain that the lamp change label is never removed, as it displays important safety information.

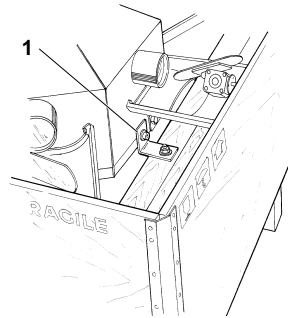

• Initial assembly operations

Fix the bracket (3) with the screws (4) and secure it by tightening the knobs (5).

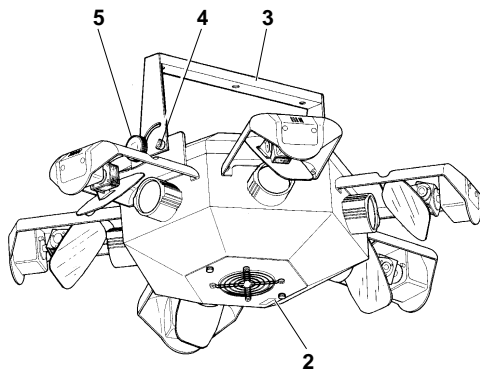

• Fitting the lamp

Refer to the directions for replacement of the lamp given under heading 5 MAINTENANCE.

• Installing the projector

The projector can be mounted in any position without its operating characteristics being affected.

IMPORTANT: fix the projector in the desired position utilizing the holes in the bracket. Secure preferably using two \varnothing 12 mm bolts complete with nuts and lock washers.

Make certain that the anchorage is stable before positioning the projector.

• Minimum distance from target objects

The projector must be positioned in such a way that objects struck by the beam are separated from the lens by a distance of at least 0.5 m. (1' 8")

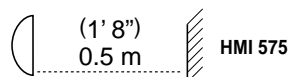

• **Minimum distance of inflammable objects from any part of the equipment:** 70 mm. (3')



The fixture may be mounted on surfaces rated normally inflammable.

IMPORTANT: For better and more reliable operation of the projector, the ambient temperature must not exceed 35° C (95° F). Protection factor IP 20: the fixture is protected against penetration of solid bodies more than 12 mm (0.5") in diameter (first digit 2), but can be damaged by spray, jet, drip or rain water (second digit 0).

2 POWER SUPPLY AND INTERFACE

• Connecting to the electrical power supply

The operations described in this heading must be carried out by a licensed electrician. The projector must be wired up to the electrical power supply using the special socket connector provided. It is good policy to connect projectors to the power supply by way of dedicated switches, so that each can be turned on and off individually from a remote station.

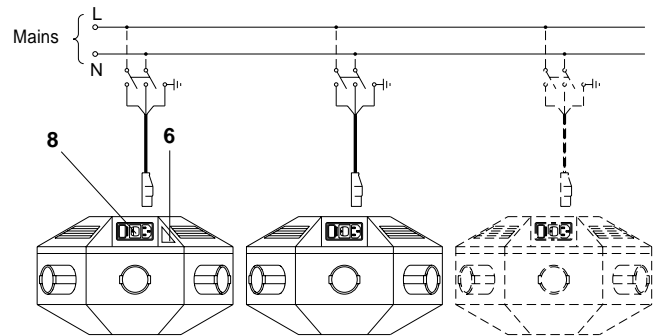

The projector is designed to operate at the voltage and frequency indicated on the electrical data plate (6) affixed to the rear end. Check that these two values correspond to the mains voltage and frequency.

IMPORTANT: the projector must be connected to a power supply circuit having a proper earth system (Class I appliance).

• Connecting the control signals: RS 232/423(PMX) - DMX 512

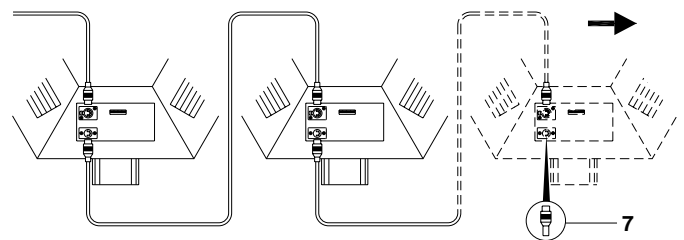

Projectors are wired up to the controller and one to the next using two-core screened cable and Cannon 5 pin XLR type plug/socket connectors. To connect a DMX line, a terminating plug (7) with a 100 Ω resistor wired between pins 2 and 3 must be fitted to the last projector connected in series; the plug is not required when using an RS232/423(PMX) signal.

The wires must not come into contact with each other or with the metal casing of the plug.

The casing of the plug/socket must be connected to the screen and to pin 1 of the connectors.

Having completed the operations described above, press the on/off switch (8). Check that the lamp comes on and that the auto-reset sequence starts.

• **Projector address codes**

Each TORNADO projector uses 8 control channels. To ensure that different projectors are addressed correctly by the controller, a code must be assigned to each one. This operation is carried out on each TORNADO by setting the microswitches as indicated in the table below.

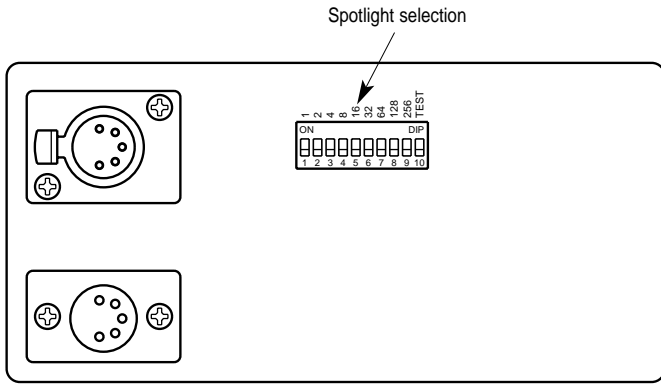

CODE	1	2	4	8	16	32	64	128	256	TEST
Projector 1- Channels 1-8	ON	▲	▼	▼	▼	▼	▼	▼	▼	▼
Projector 2- Channels 9-16	ON	▲	▼	▼	▲	▼	▼	▼	▼	▼
Projector 3- Channels 17-24	ON	▲	▼	▼	▲	▲	▼	▼	▼	▼
Projector 4- Channels 25-32	ON	▲	▼	▼	▲	▲	▼	▼	▼	▼
Projector 5- Channels 33-40	ON	▲	▼	▼	▼	▲	▼	▼	▼	▼
Projector 6- Channels 41-48	ON	▲	▼	▼	▲	▲	▼	▼	▼	▼
Projector 7- Channels 49-56	ON	▲	▼	▼	▲	▲	▼	▼	▼	▼
Projector 8- Channels 57-64	ON	▲	▼	▼	▲	▲	▼	▼	▼	▼
Projector 9- Channels 65-72	ON	▲	▼	▼	▼	▲	▼	▼	▼	▼
Projector 10- Channels 73-80	ON	▲	▼	▼	▼	▲	▼	▼	▼	▼
	ON	▲	▼	▼	▼	▼	▼	▼	▼	▼
	OFF	▼	▲	▲	▼	▼	▼	▼	▼	▲

Setting the TEST switch to the ON position for a few seconds with the projector powered-up, an auto-reset routine is carried out. Leaving the TEST switch at the ON position for a longer period, a full self-test program will be completed; once the operation has terminated, return the switch to the OFF position.

3 CHANNEL FUNCTIONS

CHANNEL	FUNCTION
1	COLOUR CHANGE
2	DIMMER/STOPPER/STROBE
3	PAN (mirrors 1 & 4)
4	TILT (mirrors 1 & 4)
5	PAN (mirrors 2 & 5)
6	TILT (mirrors 2 & 5)
7	PAN (mirrors 3 & 6)
8	TILT (mirrors 3 & 6)

• **COLOUR CHANGE channel 1**

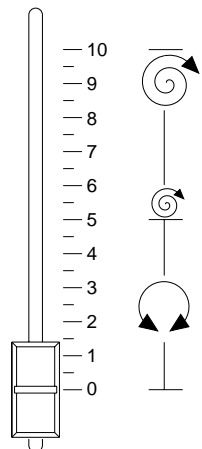

In the 0% to 50% range of adjustment, the change of colour in response to movement of the potentiometer is linear and continuous. From 50% to 100% the wheel rotates continuously at increasingly high speed.

• **DIMMER / STOPPER / STROBE - channel 2**

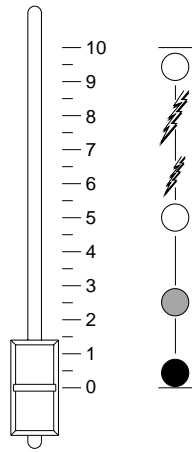

In the 0% to 50% range of adjustment the dimmer opens gradually to maximum aperture. Strobe effect is produced from 54.7% to 95% with frequency increasing from 1 flash/1.5 seconds to 5 flashes/second. The aperture remains fixed from 95% to 100%.

• **PAN - channel 3 (5) (7)**

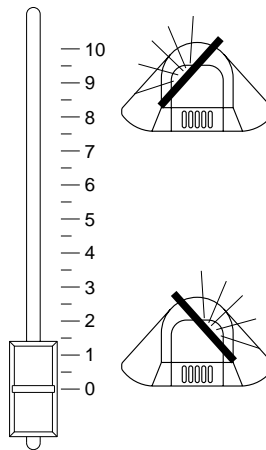

Horizontal movement of the mirrors (Pan) is linear and continuous in response to the movement of the slider from the zero position to the opposite limit of excursion. The mirrors can be stopped at any intermediate position.

• **TILT - channel 4 (6) (8)**

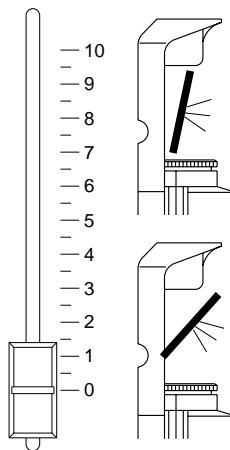

Vertical movement (Tilt) of the mirrors is linear and continuous in response to movement of the slider from the zero position to the opposite limit of excursion. The mirrors can be stopped at any intermediate position.

4 LENS UNITS

GRAPHS SHOWING BEAM DATA AND ILLUMINATION VALUES

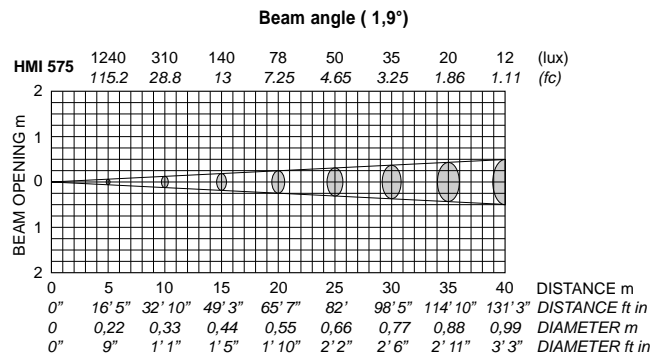

5 MAINTENANCE

IMPORTANT: isolate the projector from the electrical power supply before commencing maintenance work of any description. The maximum temperature on the outer surface of the projector under normal operating conditions is 80° C (176° F). After switching off, do not remove any part of the projector for at least 7 minutes, as indicated on the lamp change label (2). Once this time has elapsed, the risk of a lamp exploding is practically zero. If the lamp needs changing, wait a further 15 minutes to avoid the risk of burns. In the event of a lamp exploding, the projector is designed to prevent fragments of glass from being scattered. The lenses supplied with the projector must be fitted at all times, and if visibly damaged, must be replaced with genuine spares.

• Changing the lamp

Unscrew the two knobs (9) and remove the lamp change cover (10). Loosen the nut (11) of the lamp to be replaced and remove it from plate (12) gripping it by attachment (13). Remove the new lamp from its box, remove the nut (14) and loosen the other nut (11). Screw the lamp directly into plate (12) gripping it by attachment (13). Fit metal strip (15) onto attachment (16) and fully tighten nut (11). Refit cover (10) tightening knobs (9) fully.

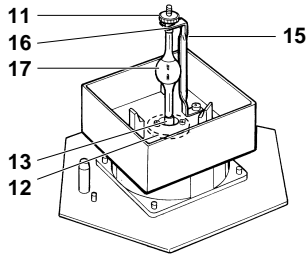
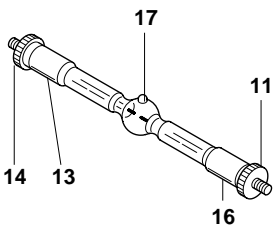
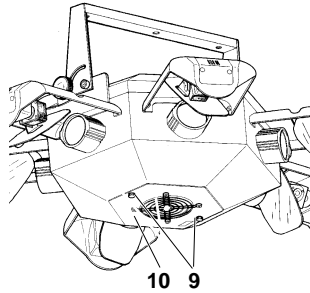

IMPORTANT: for uniform distribution of the light beam, the lamp must be positioned so that the glass pip (17) on the bulb does not coincide with any of the six optical axes of the projector.

CAUTION: The projector uses a high pressure lamp with external starter.

- When fitting a new lamp, read the manufacturer's instructions carefully.
- The lamp must always be changed without delay if damaged or deformed by heat.

• Replacing fuses

To replace the fuses, press the tab (18) and pull out the fuse holder (19). Replace any blown fuse with one of the same type and rating as indicated on the label (20) attached to the holder (19). Insert the fuse holder and push in to engage the tab (18).

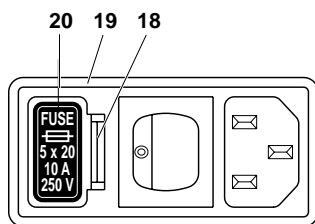

• Routine cleaning

To maintain the light output of the projector undiminished, parts that tend to accumulate dust and grease must be cleaned periodically. The projector will give long and trouble-free service if these simple guidelines are followed. To remove dirt from the lenses and filters, use a soft cloth moistened with any liquid detergent suitable for cleaning glass.

IMPORTANT: do not use solvents or alcohol

- Parts that need cleaning frequently
- Parts that need cleaning monthly

Internal components should be cleaned once a year by dislodging dust and dirt with a brush and removing it simultaneously with a vacuum cleaner.

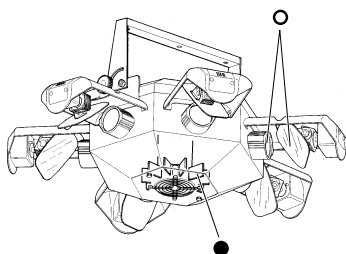

6 TROUBLESHOOTING

THE PROJECTOR DOES NOT LIGHT UP			ANOMALIES
ELECTRONICS NOT WORKING			
PROJECTION FAULTY FAULTS			
REDUCED BRIGHTNESS			CHECKS AND REMEDIES
POSSIBLE CAUSES			
●		No electrical power supply.	Check that the power supply is available at the mains socket and/or that the fuses are intact.
●	●	Lamp expended or faulty.	Change lamp (see instructions).
●		Signal transmission cable short-circuiting or disconnected.	Change cables.
●		Address codes incorrect.	See projector coding instructions.
●		Defect in electronic circuits.	Contact an authorized technician.
	●	Lenses broken.	Contact an authorized technician.
	● ●	Deposit of dust or grease.	Clean (see instructions).

7 TECHNICAL DATA

ELECTRICAL / MECHANICAL SPECIFICATIONS

- Power supply**
- 220 - 240V 50Hz
 - 200 - 220V 60Hz

Lamp

- Metal halide type with special built-in power supply unit.
- Type HMI 575W
 - Cap SFc 10-4
 - Colour temperature 6000 K
 - Luminous flux 49000 lm
 - Average life 750 h

- Power consumption**
- 1500 VA at 230V 50Hz

Motors

- N. 14 microstepping motors with full microprocessor control.

CONTROL SYSTEMS

Channels

- N. 8 control channels.

Inputs

- TORNADO is set up to accept digital control signals from controllers or computers.
- Digital serial input RS232/423(PMX) or DMX 512

MIRROR HEADS

- In diecast aluminium with epoxy powder coating.
- Very high luminous efficiency mirrors.

Movement

- Produced by two microprocessor controlled microstepping motors.
- Infinitely variable speed of rotation; maximum values:
 - PAN = 0.4 sec (150°)
 - TILT = 0.3 sec (110°)
- Continuous and uniform movement. Resolution:
 - PAN = ±0.3° (150°)
 - TILT = ±0.2° (110°)

CONSTRUCTION FEATURES

Safety devices

- Power supply shuts off automatically in the event of overheating or cooling system failure.
- Power shuts off automatically when cover is opened.

Cooling

- Forced ventilation cooling system using axial flow fans.

Housing

- In steel sheet with epoxy powder coated finish.

Mounting

- Steel bracket with epoxy powder coated finish.
- Bracket adjustable through 95°.

Operating position

- Will function in any position.

Weights and dimensions

- Weight: 35 kg (77 lbs)

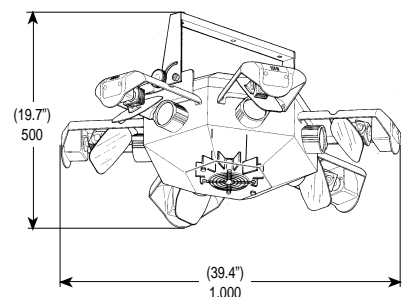

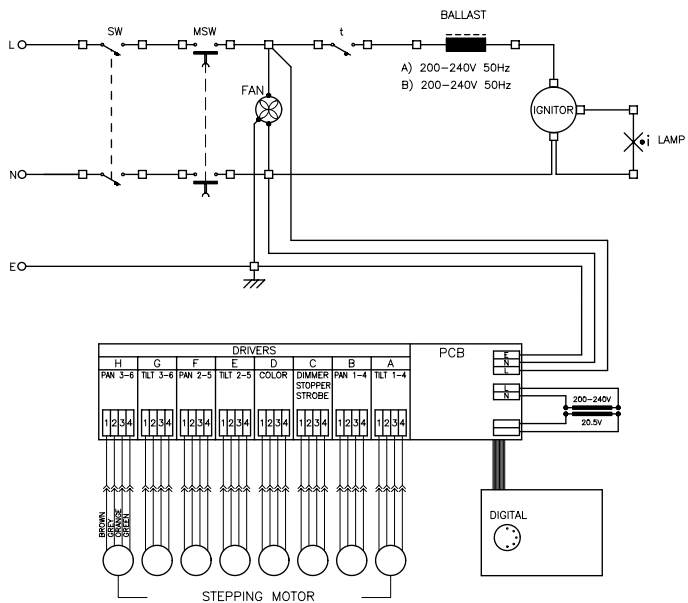

The specifications published in this manual are not binding, and may be revised or updated at any time by Clay Paky without notice in the interests of improving product quality.



The products referred to in this manual comply with EC Directives on:

- Low Voltage 73/23
- Electromagnetic Compatibility 89/336