

**GENERAL INFORMATION**

Lighting control console with 108 hands-on submasters, preset operation, moving light capability, and industry-acclaimed ETC Expression software and functionality.

- APPLICATIONS**
  - TV Studio
  - University
  - Regional Theatre
  - Special Event
  - Touring Show
- FEATURES**
  - 1536 DMX dimmers/attributes
  - 512 channels
  - 10 pages of 108 submasters
  - 100 Focus points
  - 600 Cues
  - 500 Groups
  - 2000 Macros
  - Moving Light controls
  - LTP (latest takes precedence) Channels
  - Spreadsheet Editing
  - Ethernet for DMX, Video and other signal distribution
  - SMPTE, MIDI Timecode
  - MIDI, MIDI Show Control
  - Supports ETCLink Dimmer feedback
  - Optional Full Tracking Backup
- ACCESSORIES**
  - ETC Net2 Video Node
  - ETC Net2 DMX Nodes
  - Remote Focus Unit (RFU)
  - Expression Off-Line for Windows®
  - Insight 3 LPC
  - Designers Worksheet
  - Alpha-Numeric Keyboard

**ORDERING INFORMATION**

**Insight 3**

Model#	Description
INST3	Insight 3
LPC/512	Insight 3 LPC

**Insight 3 Accessories**

Model#	Description
DNODE-RF	DMX Node - rack mount front entry
DNODE-RB	DMX Node - rack mount rear entry
DNODE-W	DMX Node - wallbox mount
VNODE-R	Video Node
RFU	Remote Focus Unit
M218	VGA Color Monitor
M219	LCD Flat Screen Display
4000A4003	Monitor Dust Cover
EOL	Expression Off Line
DWS	Designers Worksheet
M813	Alpha Numeric Keyboard - Compact



## SPECIFICATIONS

<b>SYSTEM CAPACITY</b>	1,536 DMX512 dimmers/attributes 512 control channels 600 cues 500 groups 100 preset focus points Effects with up to 100 steps each 2,000 macros/regions 108 overlapping submasters/ten pages of memory Two timed/manual fader pairs Diskette drive Dual VGA outputs
<b>DISPLAY FUNCTIONS</b>	<b>Playback Monitor</b> Fader status Cue List SMPTE Event List <b>Command Monitor</b> Stage Blind Spreadsheet Cue, Submaster and Group Lists Preset focus points Fader A/B fader C/D fader Both faders DMX512 Input Tracksheet Patch Proportional levels 32 User-definable profiles A/B Dimmer Doubling ML Patch Factory set ML personalities Park Channel or dimmer Setup Expand Flexichannel (displays only used channels)
<b>PLAYBACK CONTROLS</b>	<b>Faders</b> Two timed/manual fader pairs with Go, Hold, Rate, Clear, and Back keys Individual last action fade capability for each channel <b>Submasters</b> 108 submasters with bump buttons and integral LEDs <b>Rate wheel</b> <b>Level wheel</b> <b>Master slider</b> <b>Blackout button</b>
<b>INTERFACES</b>	DMX512 Input DMX512 Outputs (3) Ethernet ETCLink MIDI MIDI Show Control MIDI Time Code Remote Focus Unit (RFU) Remote Macro/Go SMPTE

<b>CONTROL KEYPAD FEATURES</b>	<b>Cue attributes</b> Cues from .1 to 999.9 Split up/down fade times Wait times Follow time Link to cue or macro Modified rate Label Eight-part multipart cues Selective cue recording <b>Channel Functions</b> Lists constructed with +, -, And, Thru Sneak sets channel to discrete or fader level in default/specified time. Only and Except features for group and channel manipulation Channel Attribute Display Independent channel capability Flip provides inversion of pan/tilt or lamp/scroller programming. Last Action Channels Dual fader wheels and five encoders control attributes for moving lights. <b>Moving Light Functions</b> Six pages of attribute encoders 100 Focus points 16-bit fade resolution Pop-up displays ML Patch <b>Group Functions</b> 500 groups with labels Any cue or submaster may be accessed as a group. <b>Submaster Functions</b> Ten pages of 108 submasters with labels, timing and rate attributes. Bump buttons may be enabled, disabled or solo. Range editing of submaster attributes in submaster list. Submasters 74-108 may be individually changed between pile-on and inhibitive. <b>Effect Functions</b> Live effects editing 100 steps each Step times In/Dwell/Out step times High/Low levels In/Dwell/Out effect times Effects may be recorded as cues and loaded to submasters. Range editing of effect step values and attributes <b>Subroutines</b> 100 steps with level and timing attributes Two step types Four playback styles <b>Macros</b> 2,000 macros Macros may activate any key on the console. Live Learning mode Blind editing Macros assignable to regions on Designer's Worksheet <b>Time Clock Event Programming</b> 500 events Events can be programmed for playback at specific times and days or relative to sunrise/set.
--------------------------------	--

**Note:** Not all functions described in this brochure are necessarily available immediately. Some functions that are available may be modified over the life of the product. In addition, functions not described here may also be added.



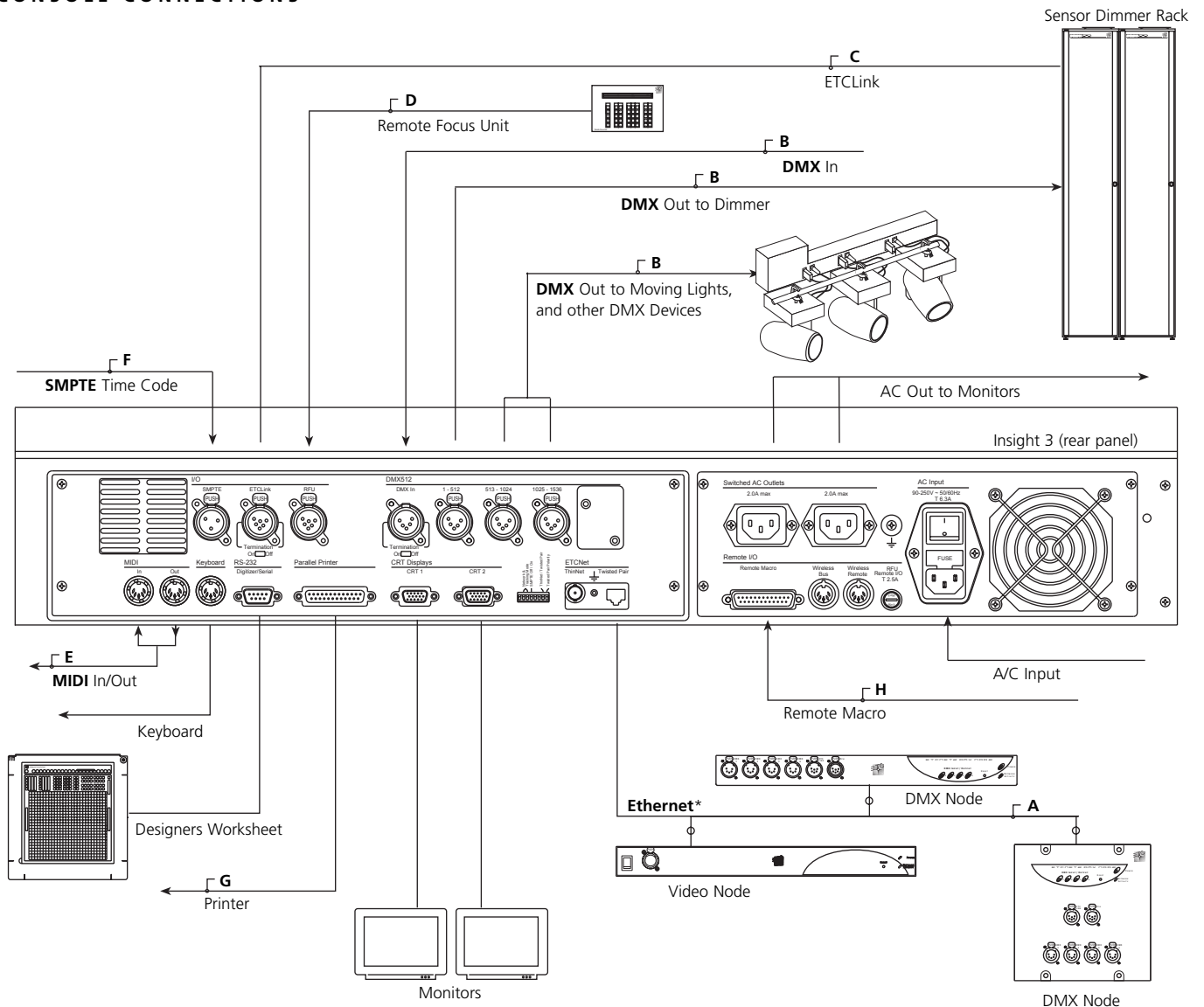

In order to maintain the highest possible standards, ETC reserves the right to change specifications without notice.



### CONSOLE CONNECTIONS

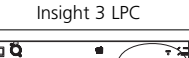
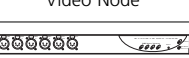

\*Ethernet distribution equipment required

### Wire Types for Insight 3 with....

Device	Wire Type	
 Insight 3	<b>Category 5 Ethernet (RJ45)</b> (1) Belden 1583A (UTP)	<b>A</b>
 Insight 3 LPC	<b>Category 5 Ethernet (RJ45)</b> (1) Belden 1583A (UTP)	<b>A</b>
 Video Node	<b>Category 5 Ethernet (RJ45)</b> (1) Belden 1583A (UTP)	<b>A</b>
 DMX Node rack mount	<b>Category 5 Ethernet (RJ45)</b> (1) Belden 1583A (UTP)	<b>A</b>
 DMX Node wall mount	<b>Category 5 Ethernet (RJ45)</b> (1) Belden 1583 (UTP) (2) #16 AWG Stranded	<b>A</b>
MIDI	Standard <b>MIDI</b> Cables 5 Pin Din Connector	<b>E</b>

Device	Wire Type	
SMPTE	<b>SMPTE (XLR3)</b> Consult Manual or ETC Technical Services for details	<b>F</b>
DMX (In + Out)	<b>DMX (XLR5)</b> Belden 9729	<b>B</b>
Printer - Parallel	Standard Parallel Printer Cable	<b>G</b>
Remote Macro	DB 25 Consult Manual or ETC Technical Services for details	<b>H</b>
 RFU	<b>RFU (XLR6)</b> (1) Belden 9728 (2) #16 AWG Stranded	<b>D</b>
 Sensor Racks	<b>DMX (XLR5)</b> (1) Belden 9729 <b>ETCLink (XLR6)</b> (1) Belden 9729 (2) #16 AWG Stranded	<b>C</b>

# Insight™ 3

## Insight Console Series

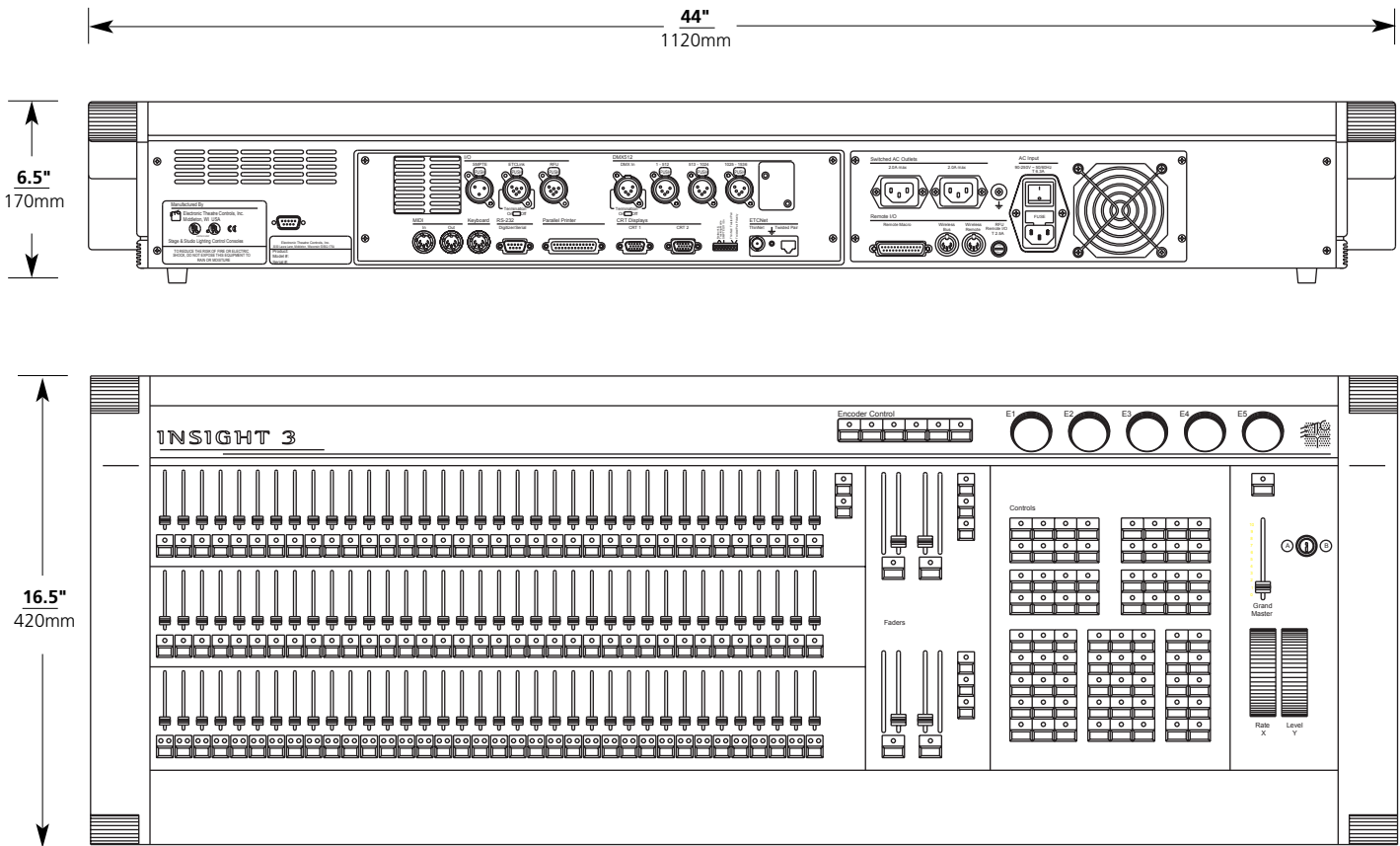

### PHYSICAL

#### Insight 3 Dimensions

Model	Height		Width		Depth	
	inches	mm	inches	mm	inches	mm
Insight 3	6.5	170	44.0	1120	16.5	420

#### Insight 3 Accessories Dimensions\*

Model	Height		Width		Depth	
	inches	mm	inches	mm	inches	mm
Insight 3 LPC	7.0	180	19.0	480	15.0	380
DMX Node - rack	1.8	45	17.0	432	12.5	320
DMX Node -wallbox	8.0	203	8.0	203	4.1	105
Video Node	1.8	45	17.0	432	12.5	320
Remote Focus Unit	1.4	34	8.5	250	5.5	140

\* Weights + Dimensions Typical

#### Insight 3 Weights\*

Model	Weight		Shipping Weight	
	lbs	kgs	lbs	kgs
Insight 3	42.2	19.2	57.0	25.8

#### Insight 3 Accessories Weights\*

Model	Weight		Shipping Weight	
	lbs	kgs	lbs	kgs
Insight 3 LPC	17.5	8.2	32.0	14.5
DMX Node - rack	8.0	3.6	18.0	8.2
DMX Node -wallbox	2.2	1.0	10.0	4.5
Video Node	8.0	3.6	18.0	8.2
Remote Focus Unit	3.0	1.4	5.0	2.3



**Americas** ■ 3030 Laura Lane, P.O. Box 620979, Middleton, WI 53562-0979 USA ■ Tel: +1 608 831 4116 ■ Fax: +1 608 836 1736 ■ Toll free: 800 688 4116 ■ Toll free fax: 800 555 8912

**Europe** ■ Unit 5, Victoria Industrial Estate, Victoria Road, London W3 6UU, UK ■ Tel: +44 (0)20 8896 1000 ■ Fax: +44 (0)20 8896 2000

**Asia** ■ Room 605-606, Tower III Enterprise Square, 9 Sheung Yuet Road, Kowloon Bay, Kowloon, Hong Kong ■ Tel: +852 2799 1220 ■ Fax: +852 2799 9325

**Web:** www.etcconnect.com ■ **Email:** (US) mail@etcconnect.com ■ (UK) mail@etc europe.com ■ (Asia) mail@etcasia.com

Copyright © 2002 ETC, Inc. All Rights Reserved. All product information and specifications subject to change. 4171L1001 Rev. B Printed in USA 03/02