



Type(s)  
Project  
Date  
Notes

**GENERAL INFORMATION**

ColorSource Linear combines the bright, bold output of the ColorSource family with a sleek linear design to create a versatile and affordable strip light. Whether being used to create a stunning wash of light on your stage or a wall, the ColorSource Linear uses ETC’s unique RGB-L color system to provide beautiful LED lighting.

**APPLICATIONS**

- Theatres and performance spaces
- Houses of worship
- Universities and schools
- Hospitality
- Retail
- Exhibition centers
- Meeting rooms
- Clubs
- Cafeteriums

**PRODUCT FEATURES**

- Available in three lengths
  - Linear 1 (0.5 meters) - one cell of control
  - Linear 2 (1 meter) - two cells of control
  - Linear 4 (2 meters) - four cells of control
- ETC’s RGB-L array (red, green, blue and lime)
  - Also available in Deep Blue, which replaces the blue LEDs with indigo for rich, saturated blues and magentas
- Homogenized optics
- Simple user interface with seven-segment display
- powerCON® in and thru power connections
- DMX in and thru (5-pin XLR)
- RDM or local configuration
- LED droop compensation for consistent output
- Optically calibrated
- Tour-ready, aluminum housing

**ORDERING INFORMATION**

**ColorSource Linear**

MODEL	DESCRIPTION	ETL PART NUMBER	CE PART NUMBER	
CSLINEAR1	ColorSource Linear 1	7414A1000	7414A1200	
CSLINEAR1DB	ColorSource Linear 1 Deep Blue	7414A1040	7414A1240	
CSLINEAR2	ColorSource Linear 2	7414A1001	7414A1201	
CSLINEAR2DB	ColorSource Linear 2 Deep Blue	7414A1041	7414A1241	
CSLINEAR4	ColorSource Linear 4	7414A1002	7414A1202	
CSLINEAR4DB	ColorSource Linear 4 Deep Blue	7414A1042	7414A1242	

Color Options: Fixtures ship standard in black. For additional colors please use the below color code suffix:

-1 for white, -5 for silver or -8 for custom

Notes: ColorSource Linear luminaires ship with a pair of trunnions and a power cable with connector of choice. C-clamps are not included. See Power Input Cables on page 8 for connector options.



PRODUCT SPECIFICATIONS

Source

LED details	40 Lumileds LUXEON® Z LEDs (per segment)
Max lumens	Linear 1: 3,039 Linear 1 DB: 2,978
Lumens per watt	Linear 1: 28.1 Linear 1 DB: 27.6
L70 rating (hours to 70% output)*	55,000 hours

Color

Colors used	Linear 1: Red, green, blue, lime Linear 1 DB: Red, green, indigo, lime
Color temperature range	Color mixing fixture
Calibrated array	Yes
Red shift	No

Optical

Beam angle range	15.6° (Secondary lenses available for multiple beam-spread options)
Gate size	N/A
Aperture size	7.5 in / 190 mm
Pattern projection	No
Pattern size	N/A
Camera flicker control/Hz range	1,200 Hz (default) and 25,000 Hz (via RDM)

Control

Input method	DMX512 via 5-pin XLR connector
Protocols	DMX512, RDM
Modes (footprint)	4 modes, see page 8
RDM configuration	Yes
UI type	Seven-segment, three-button interface
Local control	Yes
Onboard presets	Yes (12)
Onboard sequences	Yes (5)
Onboard effects	No
Fixture-to-fixture control	Yes
Notes	15-bit virtual dimming engine

**\*Note about LED luminaire lifetime:** ETC utilizes a nationally recognized third-party lab for luminaire testing according to IES LM-84. See [etcconnect.com/About/News/ETC-Fixture-Ratings-and-Warranties-Extended.aspx](http://etcconnect.com/About/News/ETC-Fixture-Ratings-and-Warranties-Extended.aspx).

All LED sources experience some lessening of light output and some color shift over time. LED output will vary with thermal conditions. In individual situations, LEDs will be used for different durations and levels. This can eventually lead to minor alterations in color performance, necessitating slight adjustments to presets, cues or programs.

Electrical

Voltage range	100–240 VAC 50/60 Hz
Input method	powerCON in and thru
Inrush (First half-cycle)	35 A / 35.6 A / 67.5 A at 120 V 49 A / 85.6 A / 153 A at 240 V
Fixtures per circuit*	9 cells (15 A power thru connector) or 10 cells (R20 module or similar)
Wattage (120 V / 240 V)	Linear 1: 115 W / 112 W Linear 2: 218 W / 213 W Linear 4: 438 W / 426 W Linear 1 DB: 110 W / 108 W Linear 2 DB: 218 W / 214 W Linear 4 DB: 440 W / 428 W
Current draw (120 V / 240 V)	Linear 1: 0.95 A / 0.48 A Linear 2: 1.82 A / 0.91 A Linear 4: 3.68 A / 1.82 A Linear 1 DB: 0.92 A / 0.46 A Linear 2 DB: 1.82 A / 0.91 A Linear 4 DB: 3.70 A / 1.83 A

\*Note: All measurements are for 120 V, 60 Hz. Results may vary in different regions.

Thermal

Ambient operating temp	0°–40° C (32°–104° F)
Fan (controllable)	Yes (No)
Droop compensation	Yes
dB range (average at 1 m)	Linear 1: 24.8 dBA Linear 2: 28.4 dBA Linear 4: 31.0 dBA
BTUs/hour (120 V / 240 V)	Linear 1: 392.38 / 382.14 Linear 2: 743.82 / 726.76 Linear 4: 1,494.46 / 1,453.51 Linear 1 DB: 375.32 / 368.50 Linear 2 DB: 743.82 / 730.19 Linear 4 DB: 1,501.28 / 1,460.34

Physical

Materials	Die-cast aluminum
Color options	Black, white, silver, or custom color
Mounting options	Yoke (1 cell - optional), trunnions
IP rating	IP20
Weight	2.9 / 9.12 / 17.01 kg (6.4 / 20.10 / 37.50 lb)
Included accessories	Power cable, trunnions

Warranty

Fixture	5 years
LED array	10 years

Regulatory and Compliance

Approved regulatory standards	cETLus Listed Conforms to UL 1573 Certified to CSA C22.2 No. 166 CE Compliant EAC Compliant
-------------------------------	---

PRODUCT FEATURES



**RGB-L COLOR MIXING**  
The custom four-color blend of LEDs incorporates a hint of lime to increase spectral reach and color depth.



**AVAILABLE IN THREE LENGTHS**  
With half meter, one meter, and two meter options, there is a ColorSource Linear for every application.



**SIMPLE USER INTERFACE**  
The simple seven-segment display and navigation buttons enable quick setup and recall of built-in presets.

COLOR METRIC INFORMATION

ColorSource Array options – Original vs. Deep Blue

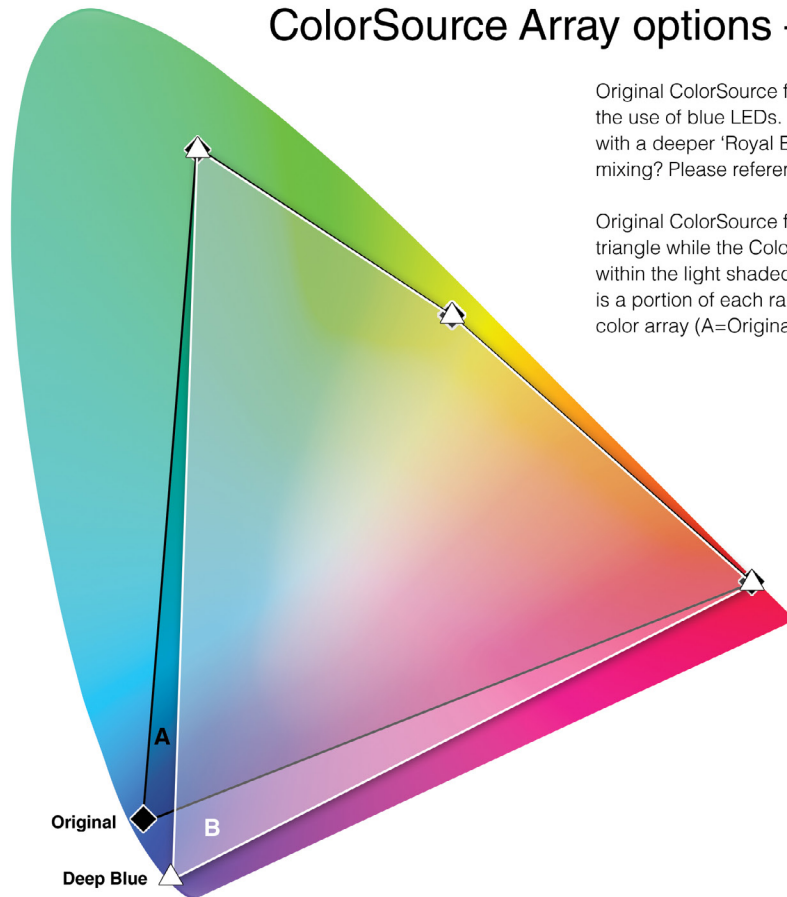

Original ColorSource fixtures use an RGB-L array where the 'B' represents the use of blue LEDs. ColorSource Deep Blue replaces those blue LEDs with a deeper 'Royal Blue' (indigo) LED. How does this impact your color mixing? Please reference the color chart.

Original ColorSource fixtures can reach any color within the dark shaded triangle while the ColorSource Deep Blue fixtures can reach any color within the light shaded triangle. While much of these areas overlap, there is a portion of each range that can only be reached by the respective color array (A=Original, B=Deep Blue).

**Common gels found in original ColorSource**

- Roscolux 095, 075, 076
- Lee 363, 119, 721, 722, 132, 141, 183, 172, 325

**Common gels found in ColorSource Deep Blue**

- Roscolux 384, 385, 382, 059, 358, 347, 049, 349, 046, 124, 027, 120
- Lee 126, 049, 798, 707, 181, 071, 120, 716

COLOR METRIC INFORMATION

COLORSOURCE LINEAR 3200 K TM-30-18

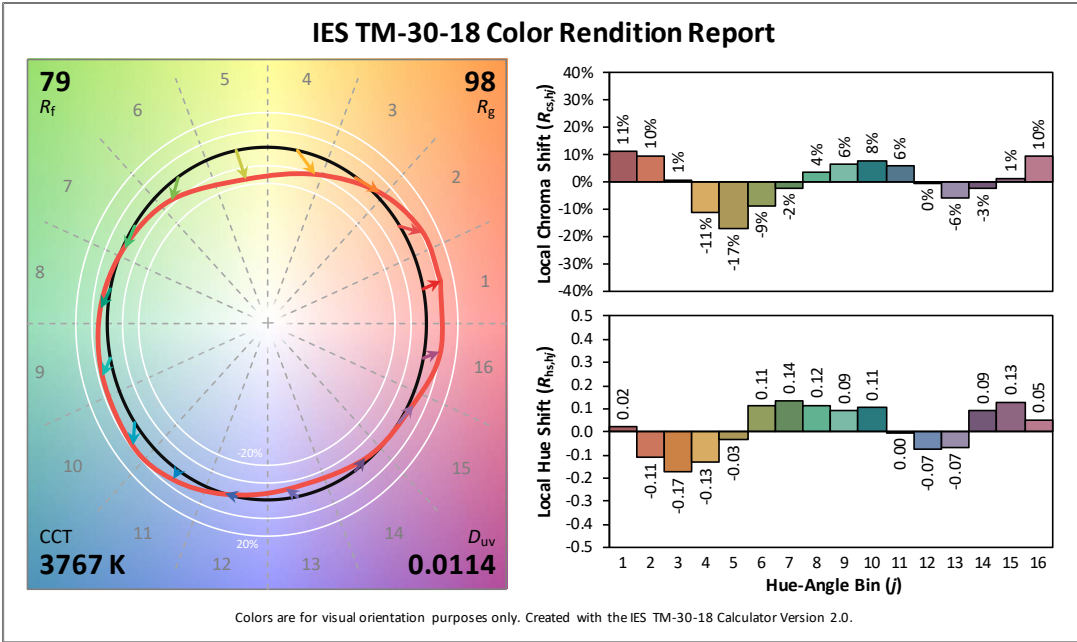

COLORSOURCE LINEAR 5600 K TM-30-18

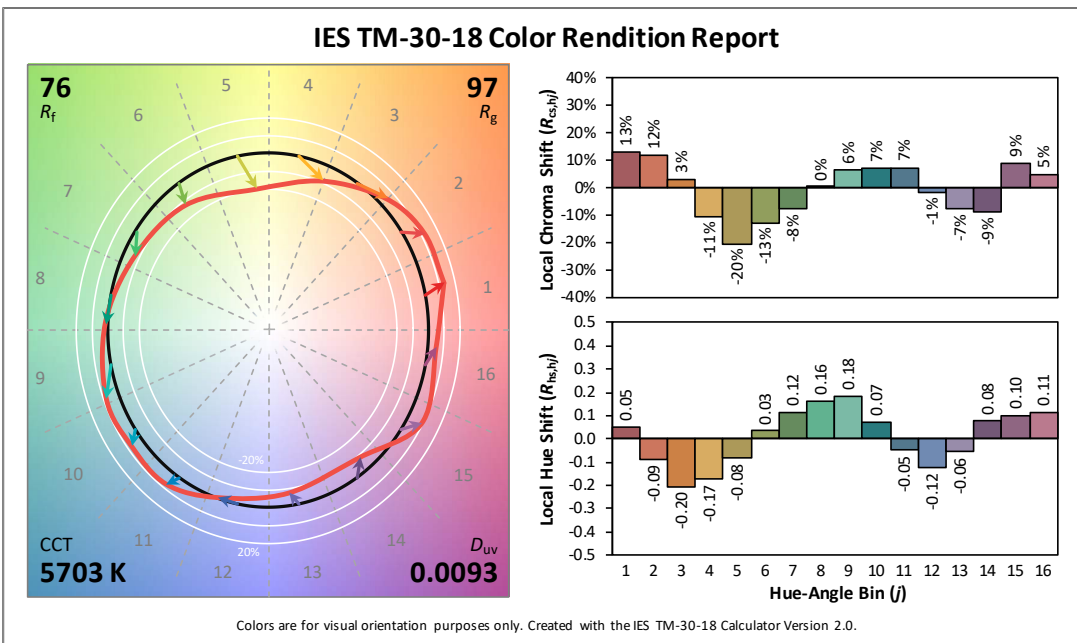

**PHOTOMETRY INFORMATION**

The photometry information shown below is for the Linear 1 (0.5 meter) fixture. Each longer Linear fixture is made up of multiple half-meter sections.

When calculating photometry for the Linear 2 multiply the information shown below by two. When figuring photometry for the Linear 4, multiply the information below by four.

Due to the physical properties of linear products, this is the best method for determining photometry for longer fixtures.

For a detailed explanation of linear photometry, please see the ETC white paper *The Validity of ColorSource Linear IES Files* at [etcconnect.com](http://etcconnect.com).

For .ies files or lensing information, use the ColorSource PAR files and assume that you have multiple fixtures (for the Linear 2 and the Linear 4) that are hung 0.5 meters on center.

**ColorSource Linear 1**

Mode	Degree	Candela	Field Lumens	Beam Lumens	Power Consumption	Lumens Per Watt
Full / RGB	27.6	35,621	2,481	1,382	93.2	26.6
Full / Direct	27.6	53,456	3,039	1,905	104	28.1
3200 K / RGB	27.6	41,323	2,380	1,494	78.9	32.9
5600 K / RGB	27.6	51,389	2,941	1,831	93.9	28.9
Red / RGB	27.6	8,190	568	305	27.8	20.4
Green / RGB	27.6	11,073	699	366	30.4	23.0
Blue / RGB	27.6	3,369	225	121	32.9	32.9

Metric conversions: For meters, multiply feet by 0.3048.  
For lux, multiply footcandles by 10.76.

**Candela Plot**

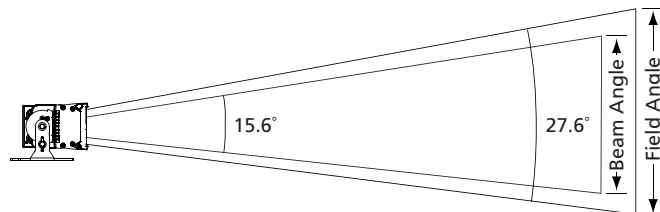
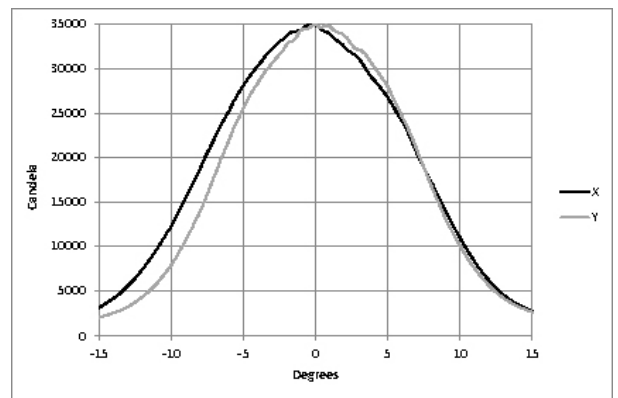

**Iso-Illuminance Diagram (Flat Surface Distribution)**

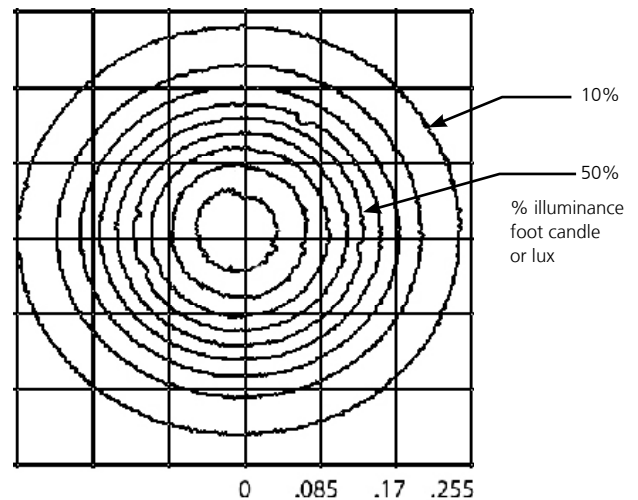

<b>Throw Distance (d)</b>	10 ft 3.0 m	15 ft 4.6 m	20 ft 6.1 m	25 ft 7.6 m	188.7 ft 57.5 m
<b>Field Diameter</b>	4.9 ft 1.5 m	7.4 ft 2.2 m	9.8 ft 3.0 m	12.3 ft 3.7 m	-
<b>Illuminance (fc)</b>	356	158	89	57	1
<b>Illuminance (lux)</b>	3,834	1,704	959	613	10.76

To determine center beam illumination in footcandles at any throw distance, divide candela by the throw distance squared.

For field diameter at any distance, multiply distance by 0.491.

For beam diameter at any distance, multiply by 0.274.

PHOTOMETRY INFORMATION

ColorSource Linear 1 Deep Blue

Mode	Degree	Candela	Field Lumens	Beam Lumens	Power Consumption	Lumens Per Watt
Full / RGB	27.2	31,917	2,141	1,173	71.8	29.8
Full / Direct	27.2	50,156	2,978	1,874	101.7	27.6
3200 K / RGB	27.2	46,653	2,772	1,738	77.5	38.3
5600 K / RGB	27.2	46,273	2,273	1,706	71.6	26.8
Red / RGB	27.2	8,221	566	308	27.5	27.5
Green / RGB	27.2	11,022	675	354	30.3	30.3
Blue / RGB	27.2	27	81	44	31.2	31.2

Metric conversions: For meters, multiply feet by 0.3048.  
For lux, multiply footcandles by 10.76.

Candela Plot

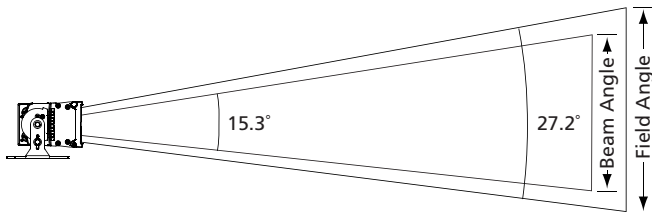
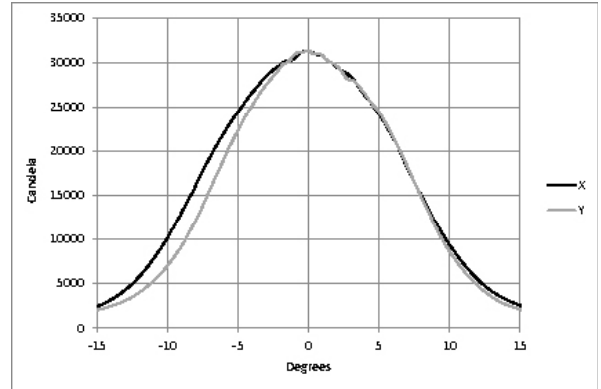

<b>Throw Distance (d)</b>	10 ft 3.0 m	15 ft 4.6 m	20 ft 6.1 m	25 ft 7.6 m	178.7 ft 54.5 m
<b>Field Diameter</b>	4.8 ft 1.5 m	7.3 ft 2.2 m	9.7 ft 2.9 m	12.1 ft 3.7 m	-
<b>Illuminance (fc)</b>	319	142	80	51	1
<b>Illuminance (lux)</b>	3,436	1,527	859	550	10.76

To determine center beam illumination in footcandles at any throw distance, divide candela by the throw distance squared.

For field diameter at any distance, multiply distance by 0.484.  
For beam diameter at any distance, multiply by 0.269.

Iso-Illuminance Diagram  
(Flat Surface Distribution)

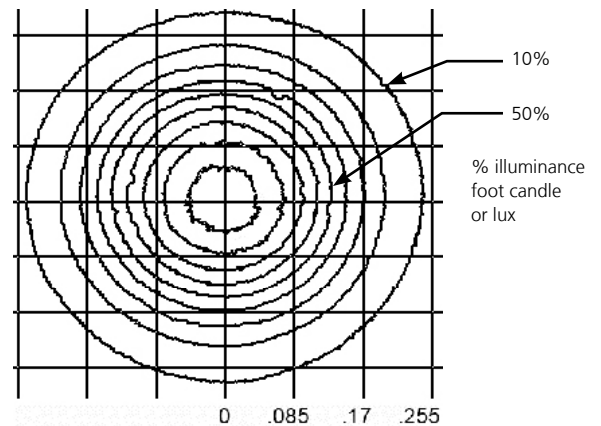

## ORDERING INFORMATION

**Secondary Lens Options**

The following lenses are cut for ColorSource luminaires and create round, linear or oblong field patterns as described below. These lenses are not sized for use in Selador Classic fixtures. Linear lenses may be combined to create desired field size.

MODEL	DESCRIPTION	PART NUMBER	
<b>HORIZONTAL</b>			
CSLNLH.5	Narrow linear horizontal lens	7414K1003	
CSLMLH.5	Medium linear horizontal lens	7414K1005	
CSLWLH.5	Wide linear horizontal lens	7414K1007	
CSLXWLH.5	Extra wide linear horizontal lens	7414K1009	
<b>VERTICAL</b>			
CSLNLV.5	Narrow linear vertical lens	7414K1004	
CSLMLV.5	Medium linear vertical lens	7414K1006	
CSLWLV.5	Wide linear vertical lens	7414K1008	
CSLXWLV.5	Extra wide linear vertical lens	7414K1010	
<b>ROUND</b>			
CSLNR.5	Narrow round lens	7414K1012	
CSLMR.5	Medium round lens	7414K1013	
CSLWR.5	Wide round lens	7414K1014	
CSLXWR.5	Extra wide round lens	7414K1015	

## ADDITIONAL ORDERING INFORMATION

**Power Input Cables**

Use information below to order 5 ft power input leads with factory-fitted connectors. CE Fixtures ship with powerCON to bare end cables in the box.

MODEL	DESCRIPTION	PART NUMBER (NOT CE)	
DPA-A	5 ft / 1.5 m powerCON to parallel blade U-ground (Edison) connector	7410B7037-A	
DPA-B	5 ft / 1.5 m PowerCON to 20 A two-pin and ground (stage-pin) connector	7410B7037-B	
DPA-C	5 ft / 1.5 m PowerCON to grounded 20 A twistlock connector	7410B7037-C	
DPA-X	5 ft / 1.5 m PowerCON to bare-end power input lead	7410B7037-X	

**Power-Thru Jumpers**

Note: Power-thru jumpers connect to luminaire's output (thru) connector to provide link to successive luminaires.

MODEL	DESCRIPTION	PART NUMBER	
DPJ-5	5 ft PowerCON to PowerCON fixture-to-fixture jumper	7410B7020	
DPJ-10	10 ft / 3.0 m PowerCON to PowerCON fixture-to-fixture jumper	7410B7010	

**Luminaire Accessories**

MODEL	DESCRIPTION	PART NUMBER	
CSL1Y	ColorSource Linear 1 yoke	7414K1017	
CSL1DY	ColorSource Linear 1 double-yoke	7414K1018	
CSLBD	ColorSource Linear barn door (2x 0.5 m sections)	7414K1020	
CSLL	ColorSource Linear louver (0.5 m section)	7414K1019	
400CC	C-clamp (does not ship with fixture)	7060A2009 (not CE)	
400SC	Safety cable (32 in)	7060A1022	
DPSJ-25	25 ft PowerCON-to-Edison input power cable with inline switch	7400B7030 (not CE)	

## CONTROL

**DMX Input Channel Profiles**

DMX Profile	DMX Channels	Channel Assignments	Notes
5ch (Default)	5	1-Intensity 2-Red 3-Green 4-Blue 5-Strobe	Lime is mixed automatically.
RGB	3	1-Red 2-Green 3-Blue	
1ch	1	1-Intensity	This mode controls the intensity of Preset 1.
Dir	6	1-Intensity 2-Red 3-Green 4-Blue/Indigo* 5-Lime 6-Strobe	*Original ColorSource Linear fixture uses blue in channel 4. Deep Blue ColorSource Linear fixture uses indigo in channel 4..



PHYSICAL

ColorSource Linear Dimensions\*

MODEL	HEIGHT		WIDTH		DEPTH	
	in	mm	in	mm	in	mm
Linear 1	4.29	109	19.61	499	6.04	153
Linear 2	4.29	109	39.37	1000	6.04	153
Linear 4	4.29	109	78.40	1991	6.04	153

\*Does not include mounting hardware.

ColorSource Linear Weights\*

MODEL	WEIGHT*		SHIPPING WEIGHT	
	lb	kg	lb	kg
Linear 1	11.20	5.10	12.80	5.81
Linear 2	20.10	9.12	23.50	10.66
Linear 4	37.50	17.01	39.87	18.08

\*Does not include mounting hardware.

COLORSOURCE LINEAR 1

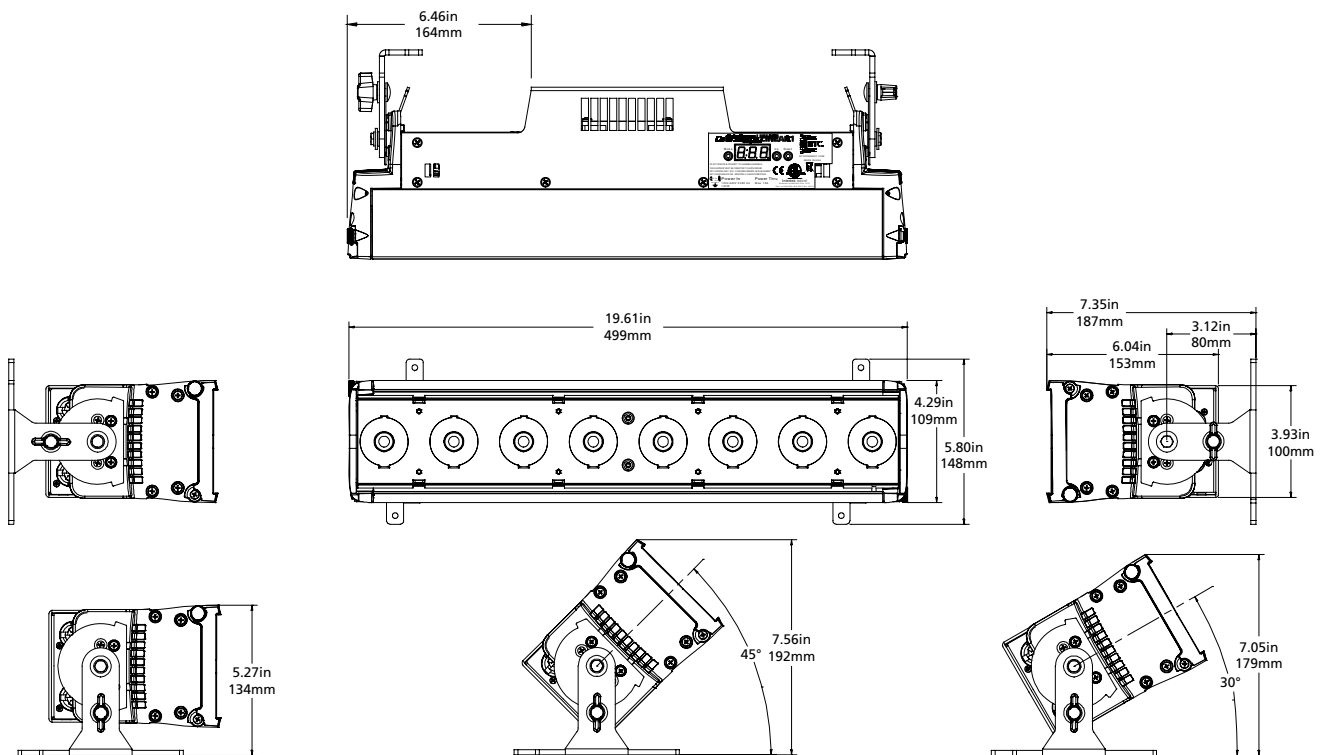

PHYSICAL

COLORSOURCE LINEAR 2

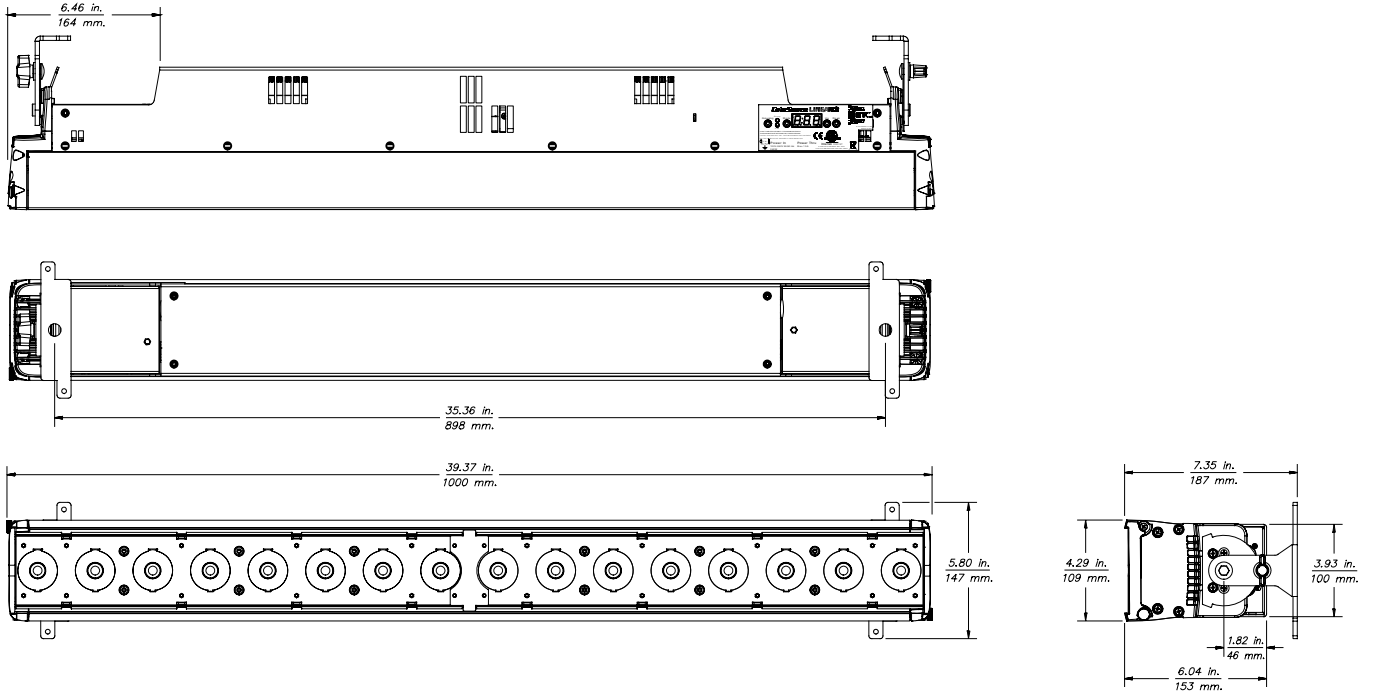

COLORSOURCE LINEAR 4

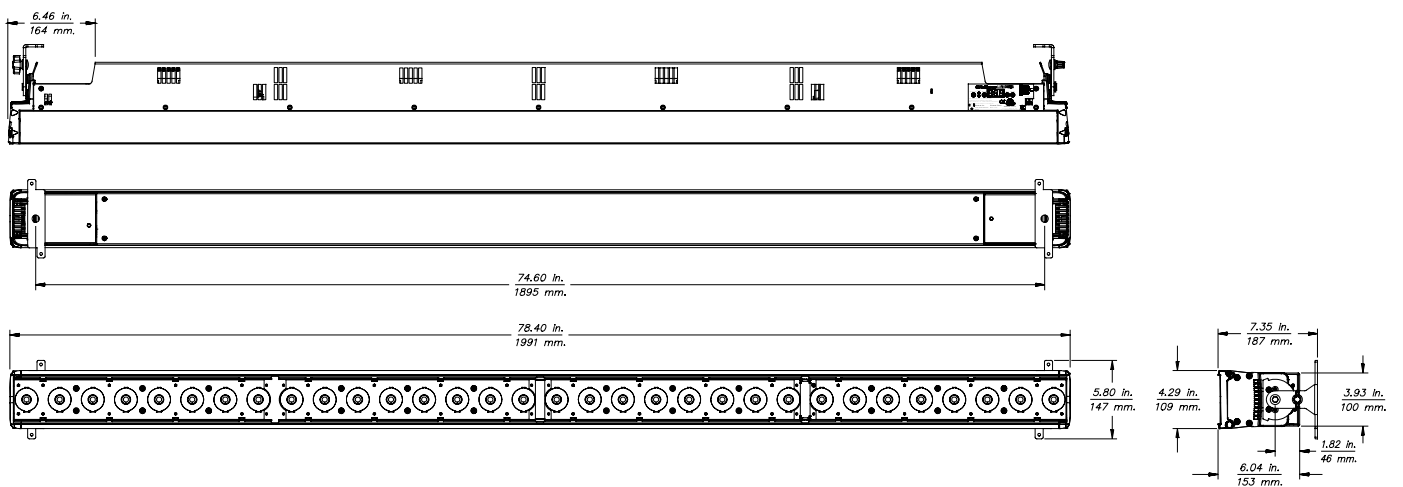

Corporate Headquarters • Middleton, WI USA  
 Global Offices • London, UK • Rome, IT • Holzkirchen, DE • Paris, FR • Hong Kong  
 Dubai, UAE • Singapore • New York, NY • Orlando, FL • Los Angeles, CA • Austin, TX  
 Copyright©2021 ETC. All Rights Reserved. All product information and specifications subject to change. Rev K 2021-09  
 \*Trademark and patent info: [etconnect.com/IP](http://etconnect.com/IP)

[etconnect.com](http://etconnect.com)