

MOUNTING

The Coda Backdrop/Cyclight is designed for interior use only. Ensure that water or condensation cannot splash onto the lamp, as this may cause it to shatter.

These units are supplied with an M.10 Bolt, Washer and Wingnut for compact suspension by a Hook clamp; the washer should be fitted immediately under the wingnut.

CODA II is designed to be used with the lamp in a horizontal position.

CODA II may also be used at stage level, e.g., as part of a ground-row lighting a cyclorama or backdrop. The construction of the lantern body gives a natural angle of 30°; the mounting fork may be used as a foot to adjust the tilt.

Always use a safety chain (order code 82000) in addition to the primary suspension; each unit has a second clip-hook to engage in the safety bond anchorage provided at the rear of the luminaire. The other end of the safety chain should be secured so that there is just sufficient free length to allow swivel and tilt adjustments. Any safety chain which has been stressed by fulfilling its function (or through misuse) must be discarded and replaced if either the links or hooks have been deformed.

Do not mount on or near a combustible surface; in extreme cases parts of the housing can reach 190°C after prolonged use. Do not use in explosive or flammable atmospheres.

CONNECTION

The Coda Backdrop/Cyclight is fitted with a short length of high temperature 3-core cable. This should be fitted with a suitable connector and connected to a mating socket to permit disconnection when relamping. When connected to the Mains

Supply, ensure that the luminaire is effectively earthed, that the Mains Supply is at the rated voltage for the equipment, and that the correct polarity is observed.

LAMP

ALWAYS DISCONNECT THE POWER BEFORE INSTALLING OR CHANGING THE LAMP.

Do not directly handle the envelope of tungsten-halogen lamps; finger prints can cause de-vitrification of the quartz, resulting in premature lamp failure. Use the protective cover supplied in the lamp carton. The cover also gives protection against flying fragments if the lamp should shatter.

To fit the lamp, loosen the screw on the Mesh Guard and remove it. Then insert one end into either of the two spring loaded lampholders; push against the spring until the other end can be inserted into the second lampholder. Take care not

to break off the ceramic end caps. When the lamp has been inserted, replace the Mesh Guard ensuring the guard is properly located in the slot in the reflector end plate and tighten the screw.

Quartz envelope tungsten-halogen lamps remain hot for a considerable time after switching off, or after filament failure, and are dangerous to handle in this condition. Allow to cool for at least five minutes before removing. Wrap the lamp in a dry cloth when removing; this will protect the hand if the envelope should still be hot and will also retain any fragments if the quartz should shatter.

ADJUSTMENT

CODA has an asymmetrical output characteristic which permits even coverage of a large area with the lanterns positioned only along one edge, e.g. at the bottom or top. They must be arranged with the flatter part of the reflector facing across the face of the illuminated area, i.e. downwards when used as a top-light and upwards when used in a "ground-row."

For optimum results CODA must not be too close to the surface to be lit; lanterns should be mounted 1.75 metres from

a 6 metre backdrop to provide a complete even coverage of the backdrop. Placing the luminaire closer to the backdrop, a vertical gradation will result. In all cases, the tilt angle must be adjusted to obtain the best result.

To avoid dark areas between adjacent luminaries (of the same colour) the maximum spacing should be the same as the distance from the backdrop.

COLOUR FRAME

Each CODA II Backdrop/Cyclight is supplied with a folded metal colour-frame.

The colour frames slide into place in the front of the lantern, the four corners engaging on lugs at the front of the housing. A small bracket is provided on one side of the frame to assist removal; this should always be on the outside when the frame

is inserted.

The frame has serrated teeth at the open end which give a soft edge to the light; the frame is reversible to allow either the top or bottom edge to have this characteristic.

Extra colour frames are available, Order Code 18123

SPARE LAMPS

The recommended lamp type is:

K1 frosted 500 Watt

Always use a lamp of the correct type and voltage rating.

Do not fit lamps of higher wattage than the recommended

maximum. It is recommended that frosted lamps be used rather than clear, because under some circumstances the shadows of the filament support on the latter may be visible, interfering with the even flood of light.

ASSEMBLY

Single unit yoke installation

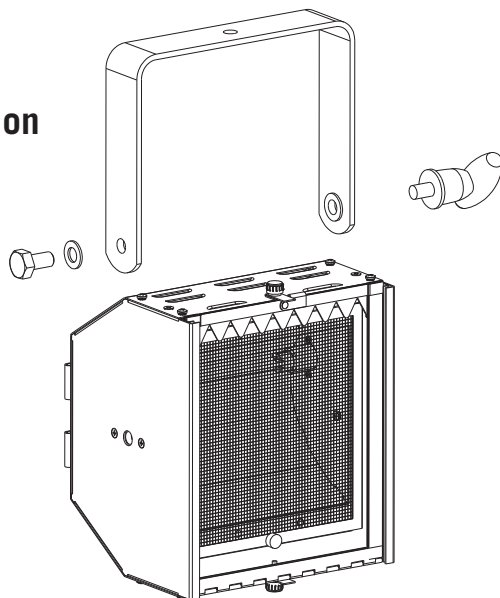

Linking multiple units

Up to 4 Coda II cyclights may be linked to form a single multi-cell/multi-colour unit by linking them using the rear brackets and top and bottom link fasteners supplied as part of each light. A single arm yoke is also provided with each light to provide hanging arms for multi-cell assemblies.

When joining adjacent units linking brackets must be installed on the top and bottom of each unit as shown here.

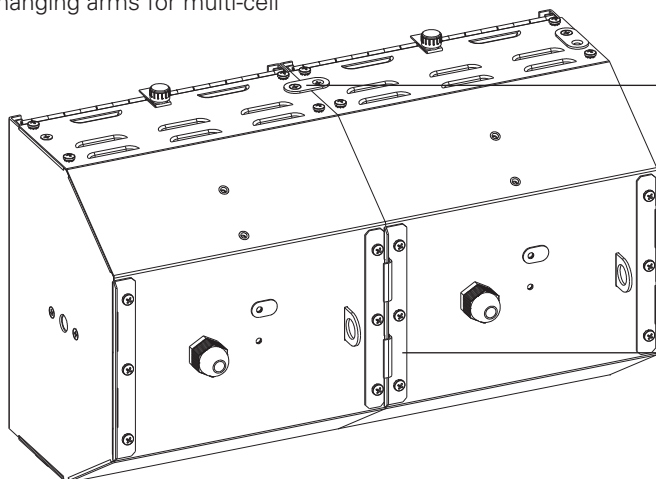

When joining adjacent units each unit must be locked into the unit next to it using this hinge assembly. A maximum of 4 units may be linked in this manner.

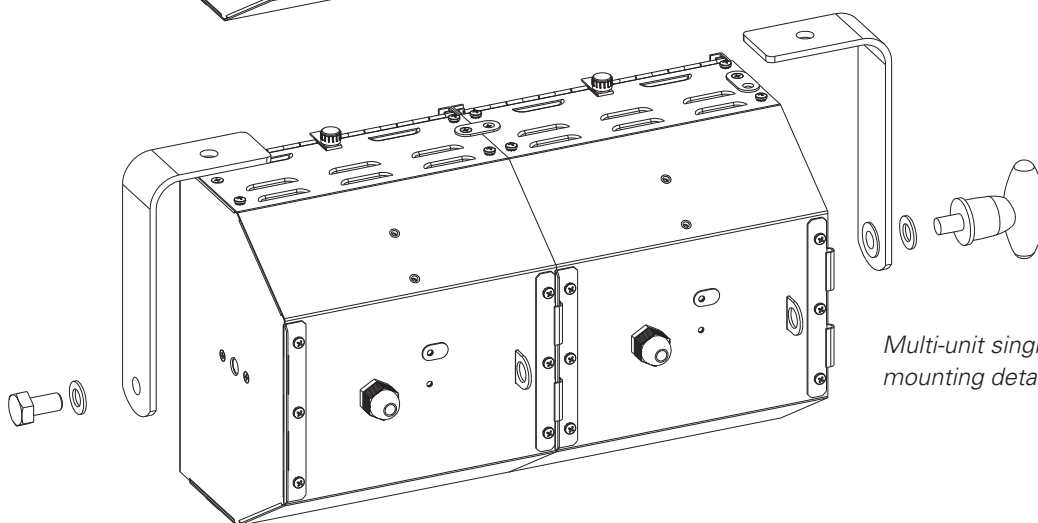

Multi-unit single arm yoke mounting detail

Strand Lighting Europe Limited

Unit 2 Royce Road, Fleming Way
Crawley, West Sussex RH10 9JY
Tel: + 44 (0) 1293 554010
Fax: + 44 (0) 1293 554019

Strand Lighting Asia Limited

20/F Delta House,
3 On Yiu Street
Shatin, N.T. Hong Kong
Tel: +852 2757 3033
Fax: +852 2757 1767

Strand Lighting, Inc.

6603 Darin Way
Cypress, CA 90630
Tel: (714) 230-8200
Fax: (714) 899-0042

www.strandlighting.com

Strand Lighting

a Genlyte company

The Company reserves the right to make any variation in design or construction to the equipment described. E&OE
© Strand Lighting Inc. 2008
Strand™ and Strand Lighting™ are trademarks of Strand Lighting Inc.