

Lekolite® Spotlight

4½" x 6½" (114mm x 165mm)
Lenses, 500W, 750W, 1000W

- ◀ Die-cast housing accepts a wide range of tungsten-halogen lamps, axially mounted for higher output
- ◀ Die-cast socket assembly allows total lamp position adjustment without tools
- ◀ Double flatted specular Alzak reflector
- ◀ Heavy gauge stainless steel shutter blades in separate planes

Specifications:

The unit shall be a 500W, 750W, 1000W ellipsoidal reflector spotlight with a medium two pin socket to accommodate an axially mounted tungsten-halogen lamp, a double flatted ellipsoidal, specular Alzak process aluminum reflector, four push shutters and a template slot, all mounted within a die-cast aluminum housing. The two 4½" x 6½" (114mm x 165mm) ground and polished borosilicate glass plano-convex lenses shall be mounted in a die-cast aluminum lens tube, designed to provide for sharp or soft definition of the beam without allowing the passage of stray light rays or extraneous internal reflections from the lens tube. This tube shall be fitted with heavy duty color frame holders. A spring-loaded latch shall permit hinged upward opening of the rear portion of the unit for reflector cleaning, without allowing accidental opening. The shutters and gate assembly shall be .049" type 302 stainless steel, and the shutters shall operate in four independent planes. Adequate ventilation shall be provided in the form of openings in the body completely surrounding the reflector and lens tube, with proper baffling to prevent light leaks. Further reduction of the temperature shall be accomplished through the use of a die-cast, finned heat sink around the lamp receptacle.

Lamp focusing shall be accomplished without the use of tools, and shall be continuously variable. Focusing shall be accomplished by moving the socket assembly axially to vary the light distribution across the field, and in a transverse plane to center the lamp. These actions shall be separate and non-interactive. The socket assembly shall be removable from the unit without tools, but shall have a stop to prevent accidental removal.

Each unit shall be supplied with a malleable iron C-clamp to grip up to 2" pipe, a die-cast aluminum yoke with locking clutch handle and three 3' (0.9m) SF2 leads in fiberglass sleeving. Exterior finish shall be baked black enamel. Overall length of the unit shall not exceed 18" (457mm). Weight shall not exceed 15½ lbs. (7kg). Entire unit shall be U.L listed and CSA approved in Canada.

The unit shall have a 42° ½-peak angle and a 65° cut-off angle, and shall produce 65 footcandles maximum at 20 feet (750 lux at 6m) using an FEL lamp set for cosine distribution for average conditions. For special applications, the lamp shall be readily adjustable to produce peak distribution with a 21° ½-peak angle and a 44° ¼-peak angle, and 205 footcandles maximum at 20 feet (2285 lux at 6m).

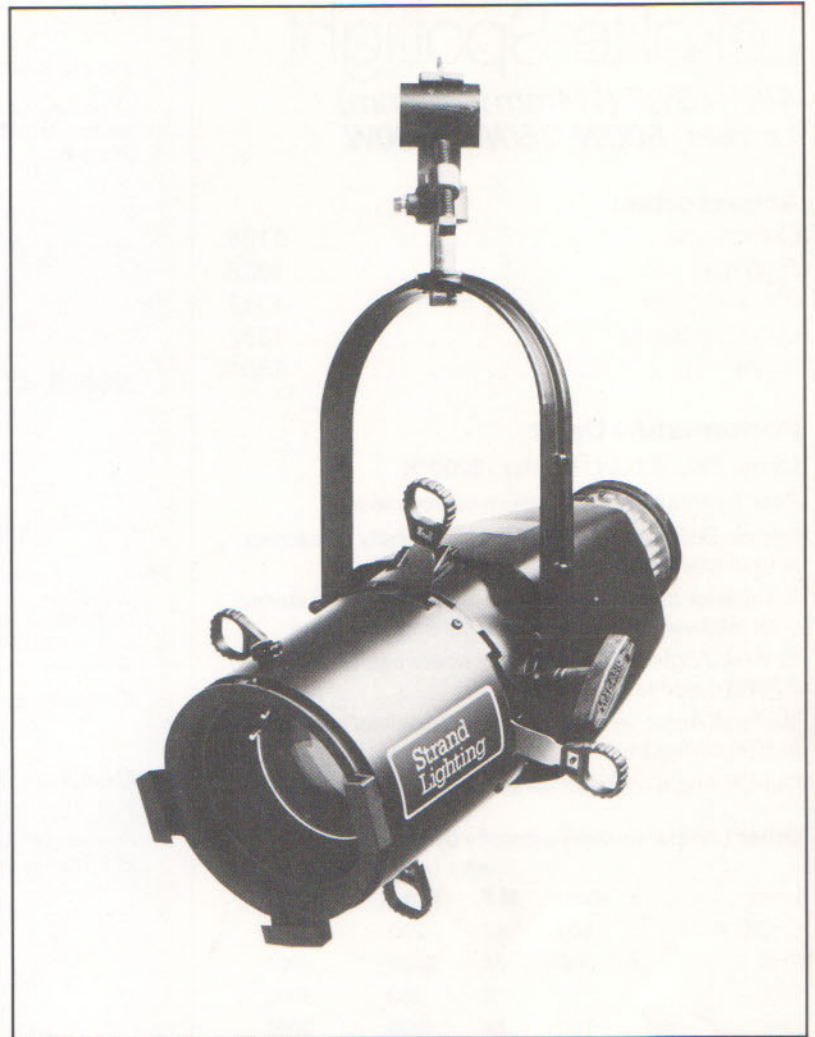

Dimensions:

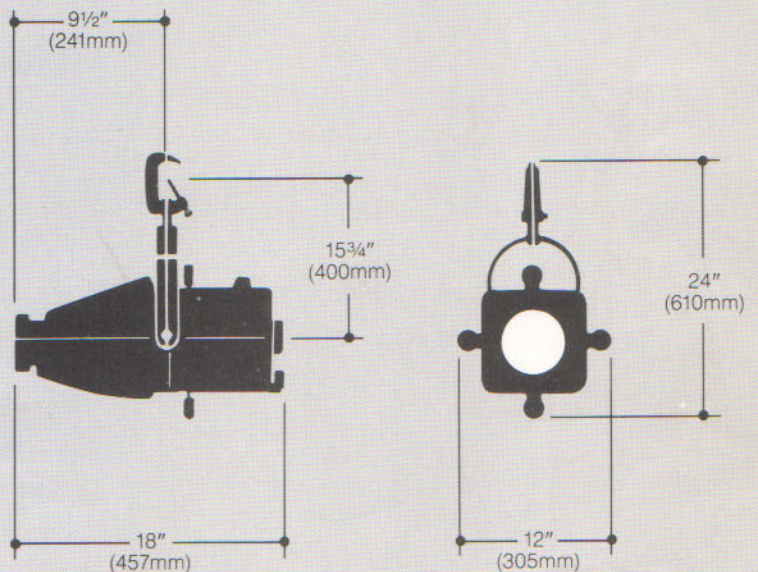

Weight: 15½ lbs. (7kg)

Lekolite® Spotlight

4 1/2" x 6 1/2" (114mm x 165mm)
Lenses, 500W, 750W, 1000W

Accessories:

Color frame	1108
High hat	1332
Pattern holder	1342
Set of 6 patterns	1352
Iris kit	1354

Performance Data:

Lamp: FEL, 1000W, 300 Hrs., 3200°K

Peak Distribution — maximum center intensity

Cosine Distribution — 1/2 of center intensity is reached at 2/3 of total spread.

Suitable for average conditions, especially when several units are overlapped for smooth lighting of an area.

1/2 Peak Angle — Beam spread where intensity drops to 50% of maximum.

1/10 Peak Angle — Beam spread where intensity drops to 10% of maximum.

Cut-Off Angle — Beam spread to edge of lighted area.

Other Lamps: multiply intensity by M.F. below:

Lamp	Watts	M.F.	Life (Hrs.)	Color Temp. (°K)
EHC/EHB	500	.47	200	3200
EHD	500	.36	2000	3000
EHF	750	.73	300	3200
EHG	750	.54	2000	3000
FKR 220/240V	650	.55	300	3100
CP77 220/240V	1000	.96	300	3200

Peak Distribution

Distance — Feet	20	25	30	35	40
Footcandles — at Center	206	132	92	67	52
Diameter — Feet	16.2	20.2	24.3	28.3	32.4

1/2-Peak Angle — 21°

21° — 44°

1/10-Peak Angle — 44°

Distance — Meters	6	7.5	9	10.5	12
Lux — at Center	2285	1465	1015	745	570
Diameter — Meters	4.8	6	7.2	8.4	9.6

Performance at Any Distance: Footcandles or Lux = 82,400/Distance²
Diameter = Distance x .81

Cosine Distribution

Distance — Feet	15	17.5	20	22.5	25
Footcandles — at Center	120	88	65	53	43
Diameter — Feet	19	22.2	25.4	28.6	31.8

1/2-Peak Angle — 42°

42° — 65°

Cut-Off Angle — 65°

Distance — Meters	4.5	5.3	6	6.8	7.5
Lux — at Center	1340	965	750	585	480
Diameter — Meters	5.7	6.7	7.6	8.6	9.5

Performance at Any Distance: Footcandles or Lux = 27,100/Distance²
Diameter = Distance x 1.27



A SUBSIDIARY OF THE RANK ORGANISATION

Los Angeles — 18111 South Santa Fe Ave, P.O. Box 9004, Rancho Dominguez, California 90224 Tel: (213) 637-7500, Telex: 664741

London — P.O. Box 51, Great West Road, Brentford, Middlesex TW8 9HR Tel: 01 560 3171, Telex: 27976

Toronto — 6490 Viscount Road, Mississauga, Ontario, Canada L4V 1H3 Tel: (416) 677-7130, Telex: 06968646

West Germany — 3340 Wolfenbüttel 16 — Salzdahlum Tel: 0 53 31/79 51-53, Telex: 95641

Hong Kong — 802 Houston Centre, 63 Mody Road, Tsimshatsui East, Kowloon Tel: 3-685161, Telex: 44953

Facilities in Paris and New York