



STUDIO 5 kW Quartz Halogen Fresnel

- Improved light quality and output, producing a flatter and more even field
- High quality, rugged, durable
- Corrosion resistant for longer life
- Compatibility of parts throughout the range
- A comprehensive range of accessories, interchangeable with existing Quartzcolor products
- Easy to service and maintain
- Bonding eyes and rigging hooks
- Front and back focusing
- New worm drive mechanism for precise focusing
- New focus system, easy to adapt from manual to pole operation and maintenance free
- Easy running adjustable barndoors ears
- Scratch resistant black non-reflective housing
- CE mark, c UL us listed



Operational data

Safety:

25 x 25 mm wire mesh guard.

Accessory fitting:

Die cast aluminium ears.
Spring loaded top catch for retention of accessories.

Tilt adjustment:

Pivot located at centre of gravity for excellent balance and positive locking.

Focus adjustment:

Front and rear focusing knobs (MO) or front and rear focusing knobs plus side mechanism (PO) for smooth and precise action from spot to flood positions

Lamp access:

Hinged lens door allows easy access for lamp replacement.

Weights & dimensions

Lens diameter	300 mm
Accessory diameter	410 mm
Filter cut size	400 x 400 mm
Weight (head + stirrup) M.O.	17 kg
Weight (head + stirrup) P.O.	20 kg
Packed weight M.O.	21 kg
Packed weight P.O.	25 kg
Packed volume	
M.O.	550 x 540 x 570 mm
P.O.	610 x 640 x 750 mm

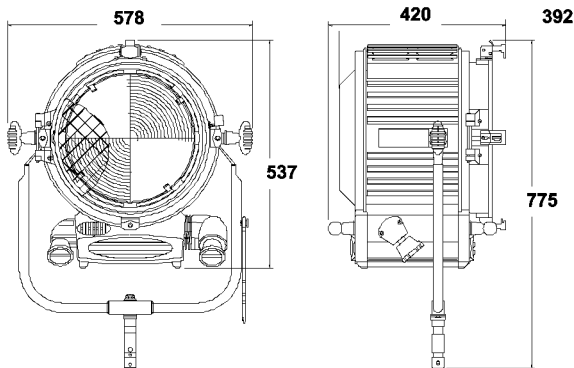

M.O.

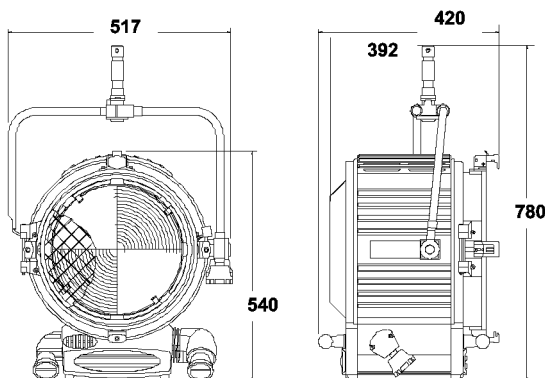

P.O.



Photometric data

Typical performance based on CP 29 - 5000 W lamp

Throw [m]

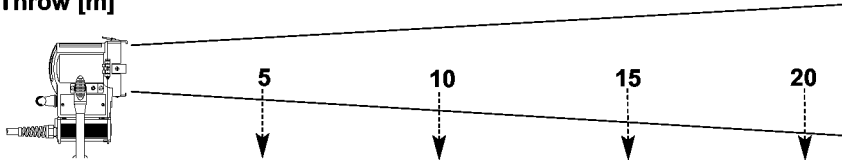

	Lux	φ [m]	Lux	φ [m]	Lux	φ [m]	Lux	φ [m]
SPOT (12°)	19,960	1	4,990	2.1	2,220	3.1	1,250	4.2
FLOOD (63.2°)	3,280	6.1	820	12.3	360	18.5	200	24.6

Lamp data

Lamp code	CP29 - 5000 W
LCL (mm)	165
Base	G38
Lumens	135000
Rated life hours (H)	500
Colour temp. (K)	3200

Mechanical data

Paint / Finish:	Powder coated epoxy paint with special extra high temperature treatment in critical areas. External textured low gloss finish
Lamp house	Die cast aluminium components, stainless steel housing
Mounting:	Robust tubular MO or PO steel stirrup with EURO spigot

Environmental Data

Max operating ambient temperature:	45°C
IP Rating:	IP 20
Tilt recommended angle of use:	-60° / 0 / 60°

Electrical data

Cable / Switching: 7 m 3 x 4 mm² with side mounted 32 A / 250 V ON-OFF rotary switch

Standards compliance: CE mark, c UL us listed

Ordering information

Cat No Description

27270	Studio 5 kW M.O. supplied with stirrup, colour frame, 4 leaf rotating barndoor
27272	Studio 5 kW P.O. supplied with P.O.stirrup, colour frame, 4 leaf rotating barndoor

Optional Accessories

Cat. No Description

28097	Colour frame
28074	4 leaf barndoor
28307	Scrim set (one double scrim, one single scrim, one half double scrim, one half single scrim)

Strand Lighting Ltd
Unit 3 Hammersmith Studios, Yeldham Road,
Hammersmith, London W6 8JF United Kingdom
Tel: +44 (020) 8735 9790
Fax +44 (020) 8735 9799

Strand Lighting GmbH
Ullsteinstrasse 114-142 D-12109
Berlin, Germany
Tel: +49 (0) 30/70 79 51 0
Fax: +49 (0) 30/70 79 519 9

Strand Lighting Italia srl
Via delle Gardenie 33 00040
Pomezia-Roma, Italy
Tel: +39 06 919631
Fax: +39 06 9147136

Strand Lighting Asia
20/F Delta House, 3 On Yiu Street
Shatin, N.T. Hong Kong
Tel: (852) 2757 3033
Fax: (852) 2757 1767



The Company reserves the right to make any variation in design or construction to the equipment described.
© Strand Lighting Ltd. 2002
Strand™, Strand Lighting™, Strand Quartzcolor™ are trademarks of Strand Lighting Limited and Strand Lighting Inc.