



BAMBINO 650W Quartz Halogen Fresnel

- ❑ Improved light quality and output, producing a flatter and more even field
- ❑ High quality, rugged, durable
- ❑ Corrosion resistant for longer life
- ❑ Compatibility of parts throughout the range
- ❑ A comprehensive range of accessories, interchangeable with existing Quartzcolor products
- ❑ Easy to service and maintain
- ❑ Large focusing knob on rear
- ❑ New worm drive mechanism for precise focusing
- ❑ Scratch resistant black non-reflective housing
- ❑ CE mark, c UL us listed



Operational data

Safety:

25 x 25mm wire mesh guard.

Accessory fitting:

Stainless steel ears. Spring loaded top catch for retention of accessories.

Tilt adjustment:

Pivot located at centre of gravity for excellent balance and positive locking.

Focus adjustment:

Rear focusing knob for smooth and precise action from spot to flood positions

Lamp access:

Hinged lens door allows easy access for lamp replacement.

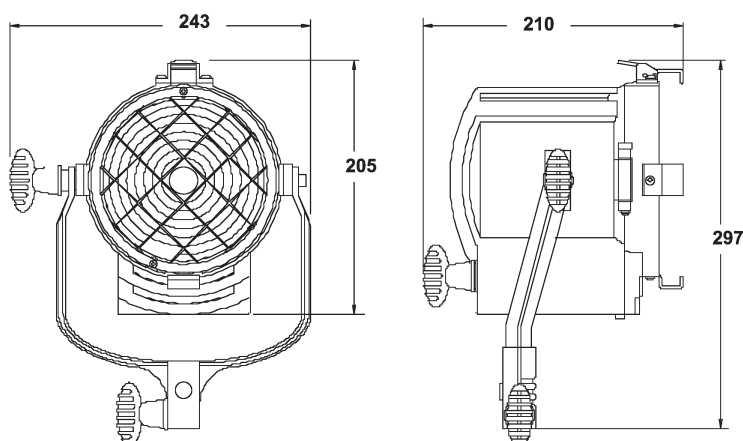

Weights & dimensions

Lens diameter	130 mm	Weight (head + stirrup)	3.5 kg
Accessory diameter	170 mm	Packed weight	4.5 kg
Filter cut size	150x150 mm	Packed volume	380x280x370 mm



Photometric data

Typical performance based on CP 89 - 650 W lamp:

Throw [m]

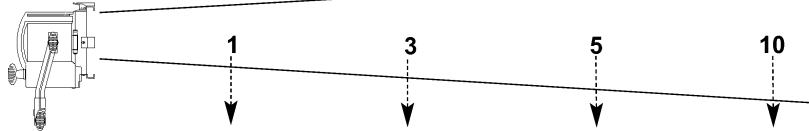

	Lux	φ [m]	Lux	φ [m]	Lux	φ [m]	Lux	φ [m]
SPOT (10.2°)	70,000	0.18	7,780	0.53	2,800	0.9	700	1.8
FLOOD (50.3°)	12,000	0.9	1,330	2.8	480	4.7	120	9.4

Mechanical data

Paint / Finish: Powder coated epoxy paint with special extra high temperature treatment in critical areas. External textured low gloss finish

Lamp house Die cast aluminium

Mounting: Die cast aluminium stirrup with BS or standard DIN socket

Environmental Data

Max operating ambient temperature: 45°C

IP Rating: IP 20

Tilt recommended angle of use: -90° / 0 / 90°

Electrical data

Cable / Switching: 4 m 3 x 1.5 mm² with in-line 8 A / 250 V ON-OFF toggle switch

Standards compliance: CE mark, c UL us listed

Lamp data

Lamp code CP89 - 650 W

LCL (mm) 46

Base GY9.5

Lumens 16250

Rated life hours (H) 150

Colour temp. (K) 3200

Ordering information

Cat No Description

- 27630 Bambino 650 W M.O.**
supplied with stirrup, colour frame, 4 leaf rotating barndoor
- 27633** as above + 230 V lamp
- 27634** as above + 240 V lamp
- 27673 Bambino 650 W (230 V) kit includes:**
3 x heads + stirrup
3 x colour frames
3 x 4 leaf barndoor
1 x set of scrims
3 x stands
3 x 230 V - 650 W lamps
1 x flight case
- 27674 Bambino 650 W (240 V) kit :**
same as p/n 27673 except with 3 x 240 V - 650 W lamps

Optional Accessories

Cat. No Description

- 28047** Colour frame
- 28048** 4 leaf barndoor
- 28309** Scrim set
(one double scrim, one single scrim, one half double scrim, one half single scrim)
- 28049** Cone
- 28030** Flight case

Strand Lighting Ltd

Unit 3 Hammersmith Studios, Yeldham Road,
Hammersmith, London W6 8JF United Kingdom
Tel: +44 (020) 8735 9790
Fax +44 (020) 8735 9799

Strand Lighting GmbH

Ullsteinstrasse 114-142 D-12109
Berlin, Germany
Tel: +49 (0) 30/70 79 51 0
Fax: +49 (0) 30/70 79 519 9

Strand Lighting Italia srl

Via delle Gardenie 33 00040
Pomezia-Roma, Italy
Tel: +39 06 919631
Fax: +39 06 9147136

Strand Lighting Asia

20/F Delta House, 3 On Yiu Street
Shatin, N.T. Hong Kong
Tel: (852) 2757 3033
Fax: (852) 2757 1767



The Company reserves the right to make any variation in design or construction to the equipment described.
© Strand Lighting Ltd. 2002
Strand™, Strand Lighting™, Strand Quartzcolor™ are trademarks of Strand Lighting Limited and Strand Lighting Inc.