

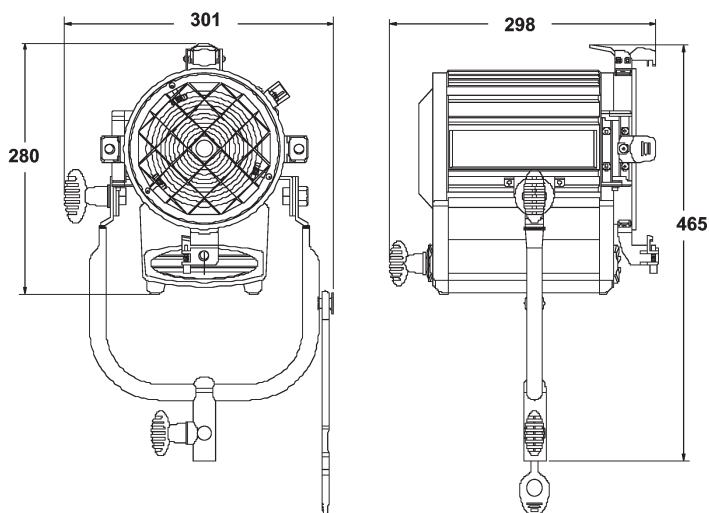

BAMBINO 1kW Quartz Halogen Fresnels

- ❑ Improved light quality and output, producing a flatter and more even field
- ❑ High quality, rugged, durable
- ❑ Corrosion resistant for longer life
- ❑ Compatibility of parts throughout the range
- ❑ A comprehensive range of accessories, interchangeable with existing Quartzcolor products
- ❑ Easy to service and maintain
- ❑ Bonding eyes and rigging hooks
- ❑ Back focusing
- ❑ New worm-drive mechanism for precise focusing
- ❑ New easy-running barndoors ears
- ❑ Scratch-resistant black non-reflective housing
- ❑ CE mark, c UL us listed



Weights & dimensions

Lens diameter	130 mm	Weight (head + stirrup)	6.5 kg
Accessory diameter	200 mm	Packed weight	8.5 kg
Filter cut size	150x150 mm	Packed volume	450x370x400 mm

Operational data

Safety:

25 x 25mm wire mesh guard.

Accessory fitting:

Die cast aluminium ears. Spring loaded top and lower catch for retention of accessories.

Tilt adjustment:

Pivot located at centre of gravity for excellent balance and positive locking.

Focus adjustment:

Rear focusing knob for smooth and precise action from spot to flood positions.

Lamp access:

Hinged lens door allows easy access for lamp replacement.



Photometric data

Typical performance based on CP 40 - 1000 W lamp:

Throw [m]

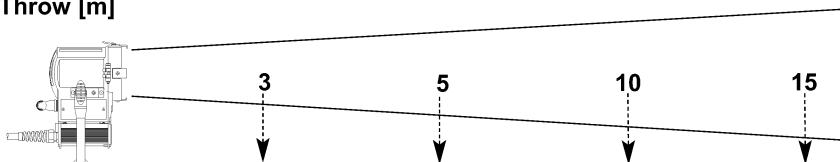

	Lux	φ [m]	Lux	φ [m]	Lux	φ [m]	Lux	φ [m]
SPOT (13°)	9,110	0.7	3,280	1.1	820	2.3	370	3.4
FLOOD (49.3°)	2,450	2.7	880	4.6	220	9.2	100	13.7

Lamp data

Lamp code	CP40 - 1000 W
LCL (mm)	63.5
Base	G22
Lumens	26000
Rated life hours (H)	250
Colour temp. (K)	3200

Mechanical data

Paint / Finish:	Powder coated epoxy paint with special extra high temperature treatment in critical areas. External textured low gloss finish
Lamp house	Die cast aluminium components, stainless steel housing
Mounting:	Robust tubular steel stirrup with BS or standard DIN socket

Environmental Data

Max operating ambient temperature:	45°C
IP Rating:	IP 20
Tilt recommended angle of use:	-90° / 0 / 90°

Electrical data

Cable / Switching: 7 m 3 x 1.5 mm² with in-line 8 A / 250 V ON-OFF toggle switch

Standards compliance: CE mark, c UL us listed

Ordering information

Cat No Description

27640	Bambino 1 kW M.O. supplied with stirrup, colour frame, 4 leaf rotating barndoor
27643	as above + 230 V lamp
27644	as above + 240 V lamp

Optional Accessories

Cat. No Description

28849	Colour frame
28846	4 leaf barndoor
28844	Scrim set (one double scrim, one single scrim, one half double scrim, one half single scrim)
28840	Cone S
28841	Cone M
28842	Cone L

Strand Lighting Ltd
Unit 3 Hammersmith Studios, Yeldham Road,
Hammersmith, London W6 8JF United Kingdom
Tel: +44 (020) 8735 9790
Fax +44 (020) 8735 9799

Strand Lighting GmbH
Ullsteinstrasse 114-142 D-12109
Berlin, Germany
Tel: +49 (0) 30/70 79 51 0
Fax: +49 (0) 30/70 79 519 9

Strand Lighting Italia srl
Via delle Gardenie 33 00040
Pomezia-Roma, Italy
Tel: +39 06 919631
Fax: +39 06 9147136

Strand Lighting Asia
20/F Delta House, 3 On Yiu Street
Shatin, N.T. Hong Kong
Tel: (852) 2757 3033
Fax: (852) 2757 1767



The Company reserves the right to make any variation in design or construction to the equipment described.
© Strand Lighting Ltd. 2002
Strand™, Strand Lighting™, Strand Quartzcolor™ are trademarks of Strand Lighting Limited and Strand Lighting Inc.