

**PHILIPS**

# Strand Lighting

**C21**

ADVANCED TECHNOLOGY DIMMER RACK



INSTALLATION GUIDE

## Strand Lighting Offices

### Strand Lighting - Dallas

10911 Petal Street  
Dallas, TX 75238  
Tel: +1 214-647-7880  
Fax: +1 214-647-8031

### Strand Lighting - New York

267 5th Ave, 4th Floor  
New York, NY 10016  
Tel: +1 212-213-8219  
Fax: +1 212-532-2593

### Strand Lighting - Asia Limited

Unit C, 14/F, Roxy Industrial Centre  
No. 41-49 Kwai Cheong Road  
Kwai Chung, N.T., Hong Kong  
Tel: +852 2796 9786  
Fax: +852 2798 6545

### Strand Selecon - Auckland

19-21 Kawana Street  
Northcote, Auckland 0627  
New Zealand  
Tel: +64 9 481 0100  
Fax: +64 9 481 0101

### Strand Lighting - Europe

Rondweg zuid 85  
Winterswijk 7102 JD  
The Netherlands  
Tel: +31 (0) 543-542516

### Website:

[www.strandlighting.com](http://www.strandlighting.com)

The material in this manual is for information purposes only and is subject to change without notice. Strand Lighting assumes no responsibility for any errors or omissions which may appear in this manual. For comments and suggestions regarding corrections and/or updates to this manual, please contact your nearest Strand Lighting office.

El contenido de este manual es solamente para información y está sujeto a cambios sin previo aviso. Strand Lighting no asume responsabilidad por errores o omisiones que puedan aparecer. Cualquier comentario, sugerencia o corrección con respecto a este manual, favor de dirigirlo a la oficina de Strand Lighting más cercana.

Der Inhalt dieses Handbuches ist nur für Informationszwecke gedacht, Aenderungen sind vorbehalten. Strand Lighting uebernimmt keine Verantwortung für Fehler oder Irrtuemer, die in diesem Handbuch auftreten. Für Bemerkungen und Verbesserungsvorschlaege oder Vorschlaege in Bezug auf Korrekturen und/oder Aktualisierungen in diesem Handbuch, moechten wir Sie bitten, Kontakt mit der naechsten Strand Lighting-Niederlassung aufzunehmen.

Le matériel décrit dans ce manuel est pour information seulement et est sujet à changements sans préavis. La compagnie Strand Lighting n'assume aucune responsabilité sur toute erreur ou omission inscrite dans ce manuel. Pour tous commentaires ou suggestions concernant des corrections et/ou les mises à jour de ce manuel, veuillez s'll vous plait contacter le bureau de Strand Lighting le plus proche.

Information contained in this document may not be duplicated in full or in part by any person without prior written approval of Strand Lighting. Its sole purpose is to provide the user with conceptual information on the equipment mentioned. The use of this document for all other purposes is specifically prohibited.

Document Number: **2-450173-040 (Rev. A)**

Version as of: **06 February 2013**

# TABLE OF CONTENTS

---

This manual describes the installation of the C21 Advanced Technology dimmer rack. The installer should refer to the separate C21/EC21 Operation Guide for detailed information concerning the initial setup procedures referred to in the Commissioning section of this manual.

Strand Lighting Offices .....	Inside Front Cover
-------------------------------	--------------------

## Table of Contents

### Preface

About This Guide .....	3
Technical Assistance.....	3
Definition of Terms .....	3

### Hardware Description

Overview .....	6
Construction.....	7
Size and Weight.....	7
Contracting Access.....	7
Supply Connection.....	7
Rack Supply Voltage and Frequency .....	7
Phasing.....	7
Dimmer Module Connectors .....	7
Control Input/Output Connection .....	7
Cooling Fans.....	8
Rack Processor Housing (RPH) .....	9
Rack Processor Module (RPM).....	9
Control Interconnection Card .....	10
Dimmer Modules.....	11
Reporting Dimmer Modules .....	11
IGBT Dimmer Modules .....	12
IGBT Dimmer Module Switch Pack .....	13

### Installation

Environmental Considerations .....	14
Conduit Layout.....	15
Positioning the Dimmer Rack(s).....	16
Preparing the Rack for Wiring .....	17
Locating Dimmer Components.....	18
Power Wiring.....	19
Dimmer Rack Bussing .....	21
Load Wiring.....	22
Control Wiring .....	23
Install the Rack Processor Housing .....	23
Connecting Power to the Rack Processor Housing.....	24
Connecting the Dimmer Control Cable Harness.....	24
Connecting the Control Signal Wiring .....	25

Control Cable Routing .....	25
Ethernet Control Wiring .....	26
DMX512 Wiring .....	27
SWC/Outlook Control Wiring .....	28
Remote Contact Closure Connections .....	29
RS232 Interface .....	30
Select Dimmers for Panic .....	31
Installing the Door .....	31
<b>Commissioning</b>	
Safety Check .....	32
Initial Power Up .....	32
Processor Self Test and Fault Identification .....	32
Rack Processor Housing LEDs .....	33
LED Status .....	33
Rack Processor Module LEDs .....	33
Dimmer Events .....	33
Output Check .....	33
Initial Programming .....	34
Programming and Fault-Finding .....	34

# PREFACE

---

## 1. About This Guide

Thank you for choosing Strand Lighting C21 Advanced Technology dimmer racks. We trust that the equipment will meet all your dimming needs and will provide you with reliable service for many years.

This manual describes the installation procedures for C21 Advanced Technology dimmer racks. A separate C21/EC21 Operation Guide describes the software operation and its use.

Strand Lighting can assure you that every effort has been made to ensure that the equipment has been designed to meet the highest professional standards and that dimmer racks and their components have been assembled, inspected, and tested in accordance with our strict quality assurance program.

Should you encounter any problems or difficulties with your dimmer racks, please contact the nearest Strand Lighting service representative. For a complete list of Strand Lighting offices and service centers, see below or visit our Web site ([www.strandlighting.com](http://www.strandlighting.com)).

## 2. Technical Assistance

C21 racks and dimmers require a minimum of maintenance and servicing.

For operation or technical assistance, please contact Strand Lighting or the local Authorized Service Center serving your area. ([www.strandlighting.com](http://www.strandlighting.com))

## 3. Definition of Terms

This manual uses the following terms throughout:

<b>channel</b>	A device controlling a dimmer or group of dimmers. Historically, there is a physical controller (such as a slider) for each channel. On most current control systems, channels are numbers accessed by a numeric keypad. Each channel can control multiple dimmers.
<b>circuit</b>	A connection device and wiring for powering a lighting fixture from a dimmer.
<b>circuit ID</b>	A unique four-digit numeric identity which you can assign to each dimmer. The circuit ID may be the same as the dimmer number, or may be a number used to indicate circuit location, phase, channel number, etc. This feature is useful for system wide control functions.
<b>crossfade</b>	A fade that contains both an up-fade and a down-fade, or any fade where the levels of one cue are replaced by the levels of another cue.
<b>cue</b>	The process of recalling a preset from its memory location and putting the result on stage. Preset, Memory, and cue are often used interchangeably.
<b>curve</b>	The relationship between a control level and the actual dimmer output.
<b>dimmer</b>	A device controlling power to a lighting fixture. Two lights on the same dimmer cannot be separately controlled.
<b>default</b>	The original factory settings.
<b>DMX512</b>	An ANSI communications protocol standard that describes a method of digital data transmission between controllers, lighting equipment and accessories.
<b>Ethernet</b>	A high-speed network based protocol used to transmit data from a lighting controller to a dimmer rack using a single Ethernet cable.

<b>fade</b>	A gradual change in stage levels from one set of intensities ("look") to another.
<b>fade time</b>	The time it takes for dimmer levels to go from their current levels to the levels in the selected preset, or DMX512 value. Each preset has its own fade time.
<b>IGBT</b>	Insulated Gate Bipolar Transistor. IGBT dimmers are solid-state and operate silently without the use of chokes and can handle a variety of load types. They reduce lamp filament noise during dimming operation, are smaller, lighter, and generate far less neutral harmonics than conventional dimmers. IGBT dimming technology provides superior overload and short-circuit protection and operates at significantly higher rise/fall times regardless of load size.
<b>level</b>	A numerical value used to express the "brightness" of the load on a dimmer. Usually shown as %.
<b>Outlook</b>	A Strand Lighting architectural control system. Outlook was eventually replaced by another Strand Lighting architectural system called Vision.net, however, C21/EC21 racks continue to support Outlook for legacy installations.
<b>patch</b>	Historically, the process of physically connecting circuits to dimmers. Now usually refers to electronic assignment of dimmers to channels.
<b>phase</b>	The three phases of the mains supply to which the dimmers are connected are identified as Line 1, Line 2, Line 3 in 230v markets and as phase A, phase B, and phase C in 120v markets.

<b>power module</b>	A chassis containing one or two dimmers or contactors. This is sometimes referred to as a "dimmer". However, each C21/EC21 power module can have multiple dimmers or contactors in it, so this manual distinguishes between dimmers (individual power control circuits) and power modules (a collection of one or more power control circuits).
<b>preset</b>	A pre-defined setup of intensities for a set of channels, stored in memory for later replay.
<b>preset fade time</b>	See " <i>Fade Time</i> "
<b>profile</b>	The relationship between a control level and the actual dimmer output. Also known as 'dimmer law' or 'curve'.
<b>rack number</b>	A number used to uniquely identify each dimmer rack in a multiple rack system. Rack numbers are set from the front panel of the rack processor module, and are usually set by the installation engineer.
<b>room</b>	An area separately defined for purposes of architectural lighting control. This is usually a room in the traditional sense (an indoor enclosed area) or a portion of a room that can be partitioned off. Each room may be separately and simultaneously controlled by the system.
<b>RPH</b>	Rack Processor Housing
<b>RPM</b>	Rack Processor Module
<b>SSR</b>	(Solid State relay) A power control device used in Strand dimmers that contains two silicon control rectifiers (SCRs), control circuitry, and optical isolation circuitry.
<b>SWC</b>	(System Wide Control) A Strand Lighting dimmer rack control system that utilized 128 backup presets. SWC was eventually replaced by another Strand Lighting architectural system called Vision.net, however, C21/EC21 racks continue to support SWC for legacy installations.
<b>Vision.net</b>	A digital architectural control system for use with C21/EC21 dimmer racks.

# HARDWARE DESCRIPTION

## 1. Overview

The C21 Advanced Technology dimmer rack is a listed, free standing, factory assembly of steel and aluminum construction finished in a fine textured, scratch resistant coating.

Each C21 dimmer rack consists of a rack processor housing (RPH) with one or two rack processor modules (RPM), a fan module, and up to 24 or 48 dimmer modules. The dimmer connectors at the back of the rack provide for load wire connection. Main bus bars are provided for line wire connections. An earth ground lug is provided in the rack. The dimmer connectors in the rack are polarized to prevent dimmer modules being plugged into different ampacity slots. The dimmer racks can be individually fed or bused together using an optional bussing kit.

Large dimmer racks have provision for up to 48 dimmer modules. Small dimmer racks have provisions for up to 24 dimmer modules. Dimmer module types can be mixed within a rack in various combinations.

Rack processor modules are available with 96 dimmer control outputs to drive C21 dimmers.

**ITEMS:**

- ① RJ45 ETHERNET JACK
- ② DIMMER MODULES
- ③ MODULE TRAYS
- ④ FAN MODULE
- ⑤ SIGNAL TERMINATION BOARD
- ⑥ PROCESSOR MODULE
- ⑦ FEED WIRING CHAMBER
- ⑧ 3-PHASE, 4-WIRE BUSS (SHORT CIRCUIT RATING = 50KA)
- ⑨ HINGED REMOVABLE DOOR

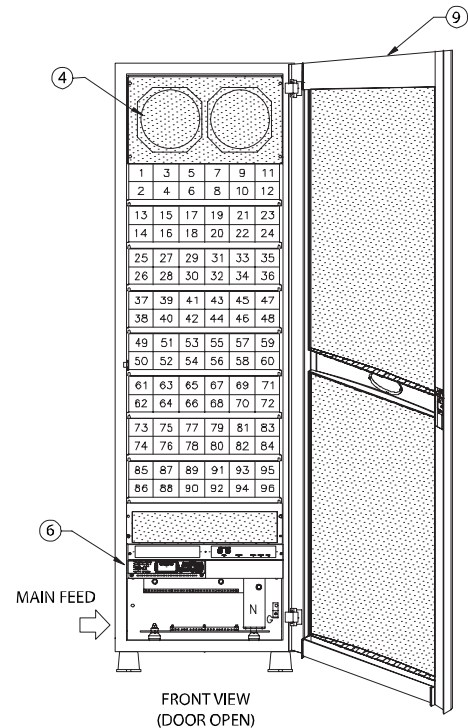
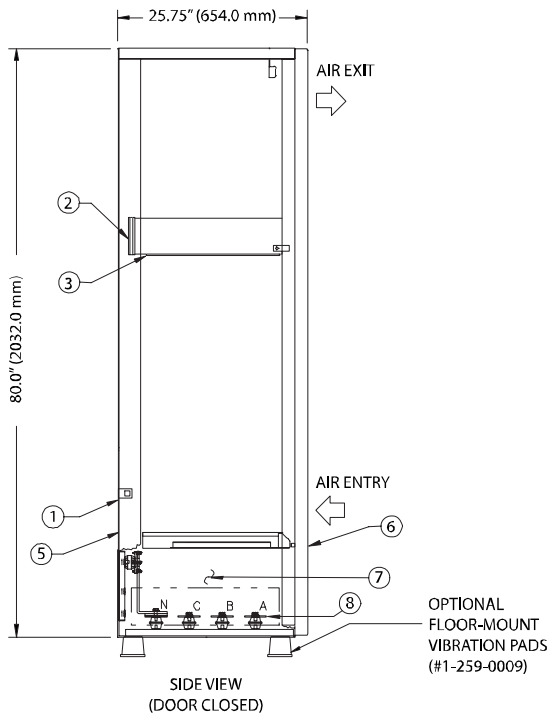
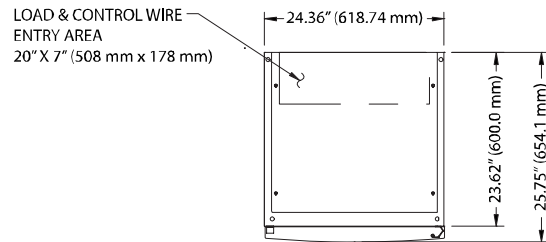

Figure 1: C21 Rack Layout (Fully Populated)



## 2. Construction

The rack is constructed of steel and aluminum and is finished in a fine textured scratch resistant coating. The rack will accept removable trays for the dimmer modules, which are screwed in place. The rack and all modules are earth grounded.

### Size and Weight

A hinged, locking door covers the front of the dimmer rack. Rack components are designed for easy removal and installation so that the dimmer rack is open and empty during installation. Mounting holes are provided so that racks can be bolted together and to the floor.

**Dimensions:** Height 80" Width 24.36", Depth 23.62"  
(Height 2032mm, Width 619mm, Depth 600mm)

**Weight:** With 48 dual standard dimmers and one rack processor module - 690 lbs (310 Kg)  
Without dimmer modules, rack processor modules – 300 lbs (136 Kg)

### Contracting Access

Power cable entry, supplying power to the bus bars is through the bottom. Contractor load wire connections for the live and neutral are through the top of the rack and directly onto the module connectors.

### Supply Connection

The rack is provided with three-phase plus neutral and earth bus bar distribution, located at the bottom of the rack. The maximum power rating for each dimmer rack is 800A per phase. Busing across multiple racks is possible using the rack interconnection busing kit.

### Rack Supply Voltage and Frequency

The C21 rack is suitable for use with supply voltages of between 90 and 264VAC power and frequency range of 47 to 63 Hz.

### Phasing

Phasing within standard dimmer racks is sequential across the dimmer slots, running in the phase sequence A, B, C, A, B, C. All dimmers in a vertical column down the rack are on the same phase. In dual dimmer modules, both dimmers are on the same phase. When looking at the front of the dimmer rack, phase A is the first and fourth columns. Phase B is the second and fifth columns and phase C is the third and sixth columns.

### Dimmer Module Connectors

The modules connect to the rack through a proprietary connector with female power pins and solid brass male power pins. The connector is self-aligning when the module is inserted. Control signals are incorporated into the connector.

The aperture is suitable for wire gauge 6 AWG or smaller, and has a tapered entry hole to ease wire insertion. The wire is retained by Allen screw. A wire adaptor is available for 2 AWG wire, when required

### Control Input/Output Connection

The Control Interconnection Card (CIC) contains all terminals for control input/output with the exception of the Ethernet receptacle that is located in the upper left rear of the rack.

## Cooling Fans

The dimmer racks are cooled by a set of low noise variable speed fans in a fan module at the top of the rack. The cooling system is designed to let the rack continue functioning if any one of the fans fail. Cooling air is pulled up through the dimmer stack and exhausted through venting at the top of the rack. These fans are for dimmer cooling only, and can be set to fixed or variable speed.

The fixed speed fan setting is for situations where changes in ambient noise are a problem. With this setting, the fans are always ON when any dimmer is energized.

The variable speed fan setting minimizes noise and maximizes fan life. With this setting, the fan speed with non-reporting modules is adjusted based on the temperature of the dimmer rack. The fan speed with reporting dimmer modules is based on the temperature of the dimmer modules and the dimmer rack. Increases in fan speed take 1 minute with this setting, while decreases in fan speed take 5 minutes. Fans are turned OFF when no dimmers are in use.

Fan and dimmer module choke noise may be acoustically objectionable. C21 Advanced Technology dimmer racks should be installed away from performance, stage and audience areas.

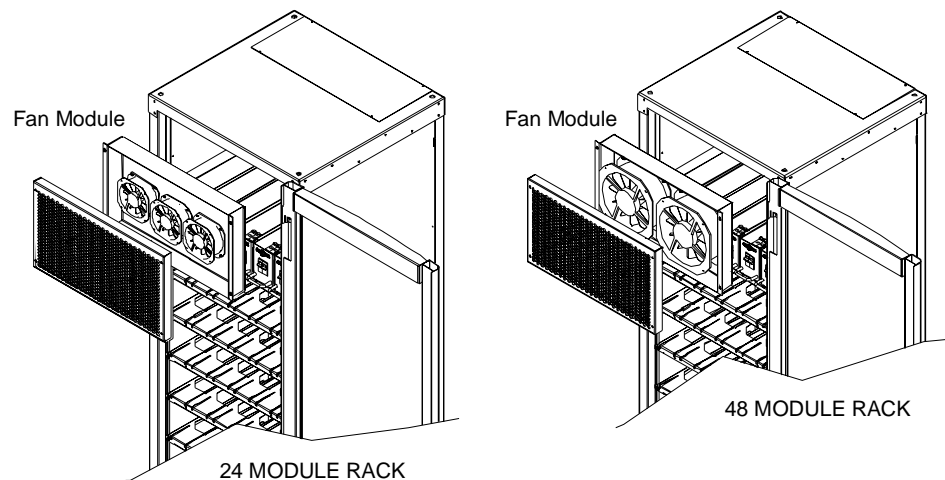

Figure 2: Fan Module

### Rack Processor Housing (RPH)

Each C21 dimmer rack contains a rack processor housing (RPH). This housing contains the rack processor module(s), power supplies, and control interconnection card (CIC) for the rack, and is shipped separately from the rack to minimize the possibility of damage.

This chassis can be equipped with one or two rack processor modules (RPM). The second processor module acts as a backup to the main processor. The configuration data from either processor is transferred into the other processor automatically. The currently inactive processor always tracks the currently active processor.

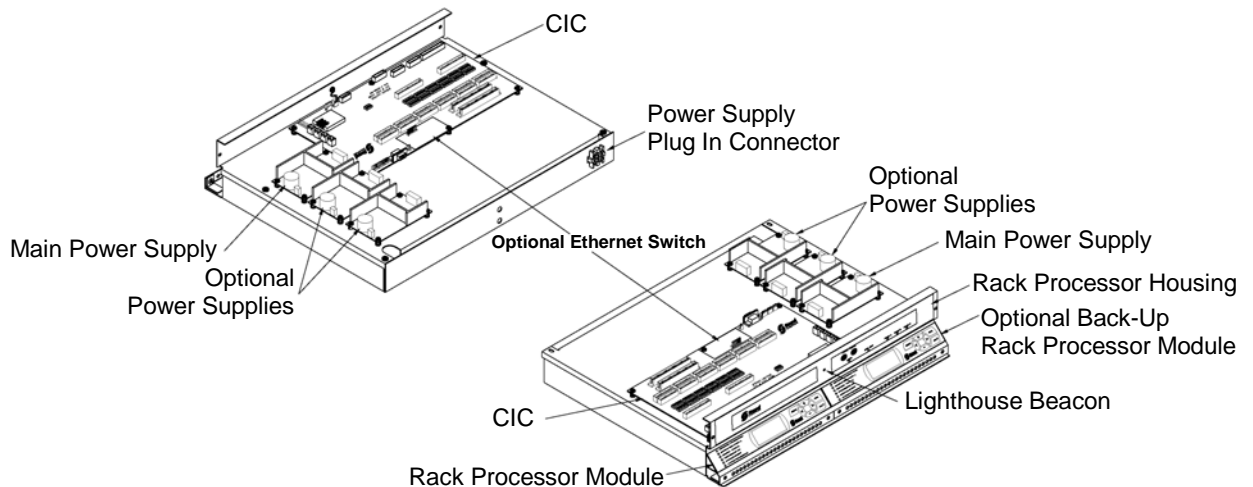

Figure 3: Rack Processor Housing (RPH)

### 3. Rack Processor Module (RPM)

Each C21 rack contains one or two rack processor modules (RPM). Each rack processor module has an LCD display, keypad, and LEDs to report processor module and dimmer status and allow simple setup and control at the rack. If there are any rack or dimmer events reported, the display will show error messages.

Pressing the [>] key takes you into a series of setup menus to view and set up the more frequently used C21 features. See the Operation Manual for details on accessing these functions.

All program data is held in non-volatile RAM within the rack processor module.

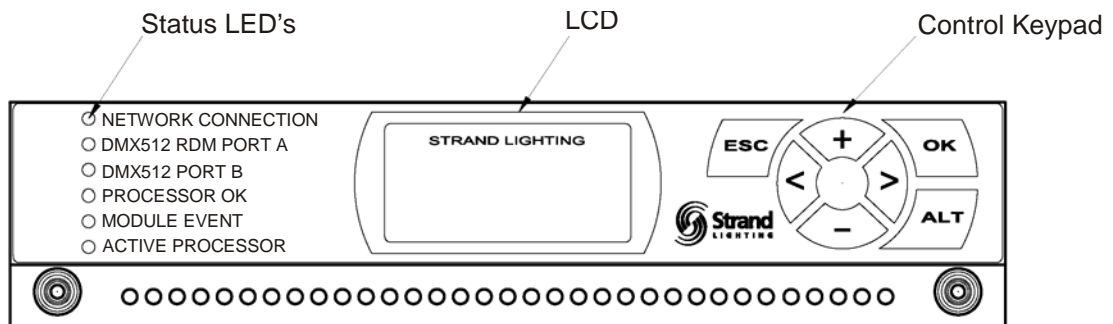

Figure 4: Rack Processor Module (RCM)

## 4. Control Interconnection Card

The Control Interconnection Card, or CIC, is the printed circuit board on which all contractor control wiring connections are made. It is located on the top of the Rack Processor Housing (RPH) and contains:

- An optional Ethernet switch, which connects to a Strand ShowNet system. This switch allows for easy connections between dimmer racks. It also connects to the network receptacle located in the upper left rear of the dimmer rack.
- Two optically isolated DMX512 control inputs. The first input will accept DMX512. The second DMX512 input is configurable to accept either DMX512 or Strand Lighting’s Vision.net architectural protocol. Each DMX512 input has a patch to allow overlapping or separation of any DMX512 control level.
- Six optically isolated contact inputs, for:

Pin	Function	Type	Description
1	PANIC ON	Momentary	Turns Panic On
2	PANIC OFF	Momentary	Turns Panic Off
3	FIRE ALARM	Maintained	Turns Panic On, No Override
4	SWC PRESET 1	Momentary	Fires SWC Preset 1
5	GO NEXT SWC	Momentary	Fires "Next" SWC Preset
6	GO SWC OFF	Momentary	Fires SWC Preset 0 (Blackout)
7	Com/Gnd	-	Com/Gnd
8	Com/Gnd	-	Com/Gnd

- An Audio Visual Interface port. This serial input will support connection to an external A/V or show control system that supports an RS232 or RS485 serial connection.
- 96 panic select switches

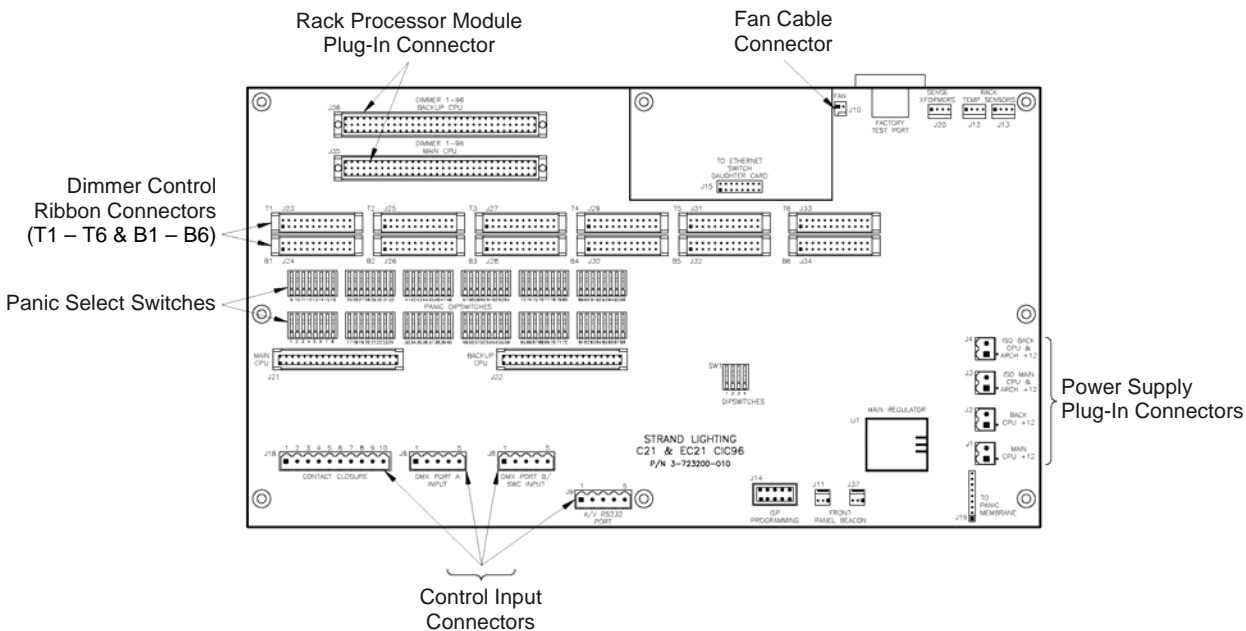

Figure 5: Control Interconnection Card (CIC)

## 5. Dimmer Modules

The power modules are the high power switching section of the C21 dimming system. The power block in this module is the interface between the high power AC and low power control. It is driven by low level signals (5mA, 3-24V) and switches high level signals (up to 100A, 120/240VAC). High specification filtering, SCR dimming, contactor non-dims, IGBT dimming, and load status reporting electronics are available as options. Dimmers can be mixed in any combination in a rack. This lets you use the exact dimmer type needed for each circuit.

Power modules are constructed from aluminum, folded to form three sides of the dimmer and to support the dimmer connector and heatsink. The fourth side of the dimmer is formed by the heatsink. The top and bottom of the dimmer are open for cooling.

A sturdy handle is provided below the circuit breakers.

An optional locking bar on the dimmer tray secures the dimmers in the rack.

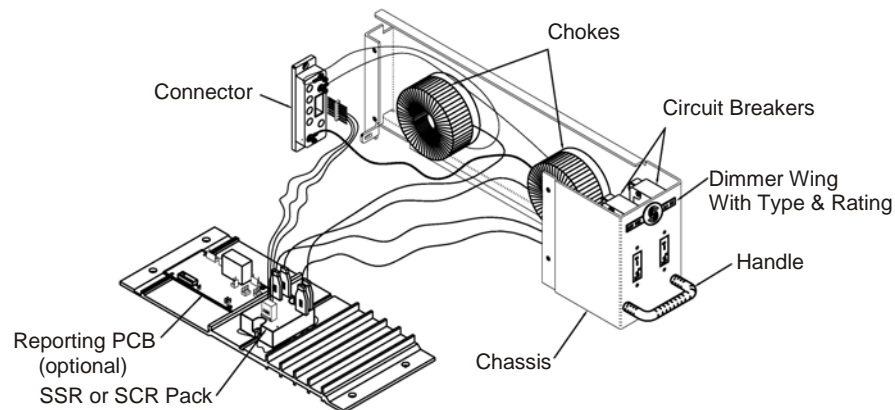

Figure 6: Dual Dimmer Module

### Reporting Dimmer Modules

Most C21 dimmer modules are available in load status reporting versions. Load status reporting versions of dimmers can be mixed in any combination with standard dimmers in C21 racks. These dimmers report many dimmer status items back to the processor. The information can be accessed through various menu items. The processor can then display a wide range of faults and diagnostic data.

Each Reporting dimmer module contains a temperature sensor which will shut it down if it overheats. Anything causing overheating in the rack will cause a gradual shutdown as each Reporting dimmer module overheats.

## IGBT Dimmer Modules

C21 IGBT electronic dimmers provide users with exceptionally quiet and efficient dimming for a wide range of loads. Each IGBT dimmer features forward and reverse phase control operating modes suitable for dimming incandescent and low voltage loads as well as a broad range of LED loads.

All C21 IGBT dimmers offer low insertion loss and microprocessor controlled over current and short circuit protection. Resetting the dimmer to zero percent (0%) from the control system will restore operation in the event of a module shutdown.

---

---



### WARNINGS!

- Make sure that the neutral wire is landed correctly with its corresponding load wire for proper operation. Failure to do so will cause the dimmer module to shut down.
  - Since the IGBT dimmer module monitors the dimmer rack power feed at all times, it is imperative that the power feed is clean and free of any distortion.
  - In the presence of poor quality power with significant mains disturbances, the IGBT dimmer module may shut down to protect the IGBT power devices.
  - IGBT dimmer modules should be configured as "Sinewave" module types when configuring the C21 dimmer rack processor.
- 
-

### IGBT Dimmer Module Switch Pack

The DIP Switches located at the side of the IGBT dimmer module allow for configuration of dimmer options.

**Note:** Dual-channel modules have a separate switch pack for each channel.

- **CONTROL MODE** - (Factory Default ON) (Factory Default: Force FPC) Dimmer racks must be operated under normal conditions with all dimmers configured to Force FPC. If directed by Strand Technical Support, changing this switch to the AUTO mode position will allow the dimmer to automatically sense the load type and select either Reverse Phase Control or Forward Phase Control, based on the load's behavior. AUTO mode should be used only when a load does not operate properly in the default Force FPC mode.
- **RPC LOCK (LED)** - (Factory Default: Normal) When used in combination with CONTROL MODE = AUTO, setting this switch to the Force RPC position locks the dimmer into reverse-phase-control only operation, which may be required for certain LED loads. Always set this switch to Normal in all other cases.
- **TRANSITION CONTROL** - (Factory Default Automatic) Automatic operation allows the IGBT dimmer to monitor and adjust its transition control (up to 1000uS in 120V installations, and up to 650uS in 230V installations) based on several operational factors. The "Fixed at 400uS" position should ALWAYS be used when the dimmer is operating a phase-controlled electronic ballast or LED driver as its load, because these devices expect fixed transition times for proper dimming level selection.
- **FULL OUTPUT VOLTAGE** - (Factory Default: 120V / 240V) These switches select the RMS output voltage to be delivered by the dimmer when the control level is 100%. Choose a non-default value if lamps of a lower voltage rating (e.g., 115V on 120V) are used in the lighting rig.
- **PREHEAT** - (Factory Default: Preheat Disabled) When changed to the non-default position (Preheat Enabled), the dimmer will generate a very low voltage to the loads, when they are "off", to keep the filaments heated, improving response time. This feature should only be enabled on larger-wattage, incandescent lamps and only when faster turn-on response is required.

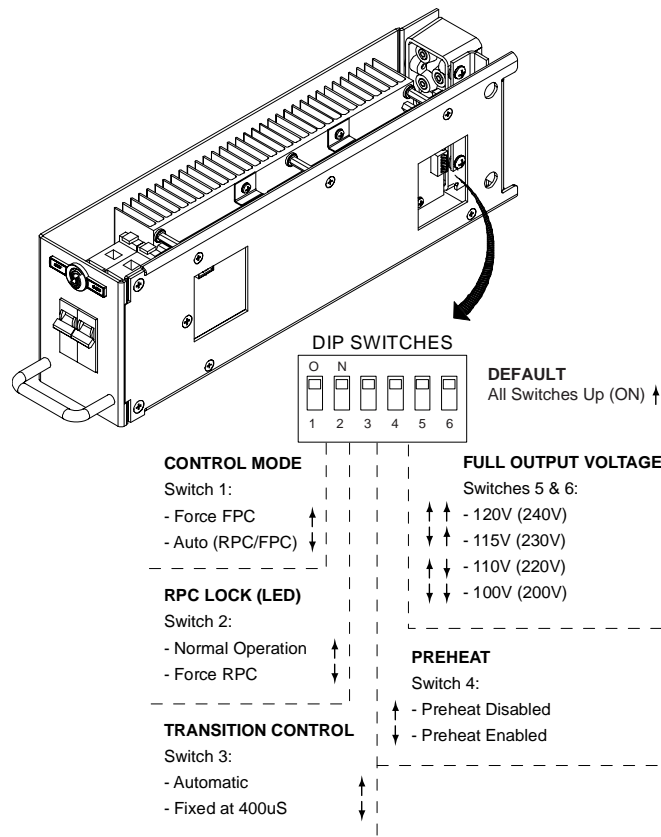

**CAUTION:** It is never recommended to set the switches to Reverse Phase Control (RPC) for an entire rack of IGBT modules.

Figure 7: DIP Switch Settings

# INSTALLATION

---

## 1. Environmental Considerations

Before installing your C21 dimmer rack, you should carefully consider the environment in which the equipment is to be installed, the power feeding the equipment and the required conduit and/or cable runs.

To maximize equipment life and minimize the chance of failures, the following environmental requirements should be met:

- Operating temperature: 1 to 40°C ambient
  - Operating humidity: 5%-95% non-condensing
  - Storage temperature: -40°C to 70°C
  - Storage humidity: 0% to 95% non-condensing
  - Shock resistance in transit without damage: 40G 10mS in any of the X, Y, Z planes
- 
- 



### WARNINGS!

- Dimmer rack efficiency is at least 97% with standard modules. Since the remainder of the energy is dissipated as heat, racks should be installed in a room with adequate ventilation to dissipate a heat load equivalent to at least 3% of the maximum load the dimmer racks will handle
  - Electrical equipment must not be used in close proximity to flammable materials.
  - This equipment is for indoor use only
  - AC Lighting Loads Only!
  - The short circuit rating for this product is 50,000 AIC. Provisions can be made for optional amp trap devices to provide 100,000 AIC fault current protection, if required.
  - Fan and filter choke noise emissions at some levels may be objectionable, therefore racks should be installed away from stage and audience areas.
  - Do not obstruct the ventilation at the front of the dimmer rack
  - A 90 to 264VAC, 3-phase, 4-wire plus ground, 47 to 63Hz power source must be provided for processor assembly power. Processor assemblies operate on any power source in the listed range, but the power source must be correct for the dimmers used in the system. Dimmers are available in 120V and 230VAC models. Please consult Strand Lighting on the actual main feed size required for specific installations.
  - Strand Lighting recommends that the dimmer rack power be a separate feed and that no other equipment share the feed. Because of electrical and RF noise generated by SCR based dimmer modules, transformers having a K-factor of 14 or more are recommended because of the high third harmonic content generated by dimming equipment.
  - Do not install this equipment with power applied.
  - Make sure that incoming power is disconnected before proceeding with the installation.
- 
-



## 2. Conduit Layout

The location of conduit runs and their entrance to the dimmer rack is important and should be carefully planned before cutting holes or attaching conduit.

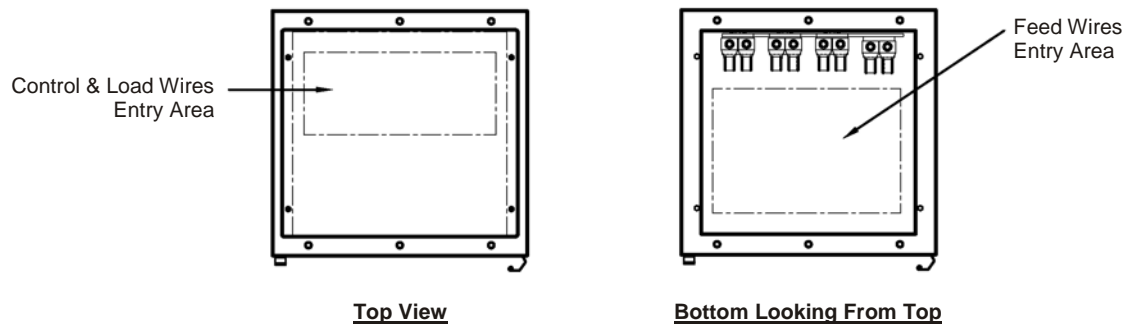

Figure 8: Recommended Conduit Cutouts (Top and Bottom of Rack)



### WARNINGS!

- **Do not** run power feed or load wires in the same conduit or wireways as control and low voltage wiring.
- **Do not** run load cable trays and/or conduit in close proximity to any computer or computer equipment.
- **Do not** run wiring from other unrelated equipment in the same conduit with C21 wiring.
- **Do not** run control wires from dimmer rack locations marked for load or power wires, and vice versa. These locations are chosen to minimize electrical interference between various sections of the system.
- **Do not** run wiring in ways other than shown on the system riser diagram or use alternative control cables to those specified by Strand Lighting.
- **Do not** substitute plastic conduit for metal conduit. Metal conduit acts as a ground and shield.
- **Do not** substitute shielded wiring for unshielded wiring or conduit. Changes in transmission line capacitance can cause problems with the control signals.

### 3. Positioning the Dimmer Rack(s)

Fan and choke noise may be objectionable if the racks are installed close to audience or performance areas. Install the racks in dedicated mechanical rooms remotely located from the stage, audience, and acoustically "live" positions of the performance area.

Attach the racks to a sturdy wall and to the floor. Mounting holes are provided for this purpose. Racks may be placed in a "back-to back" configuration if they are attached securely to the floor.

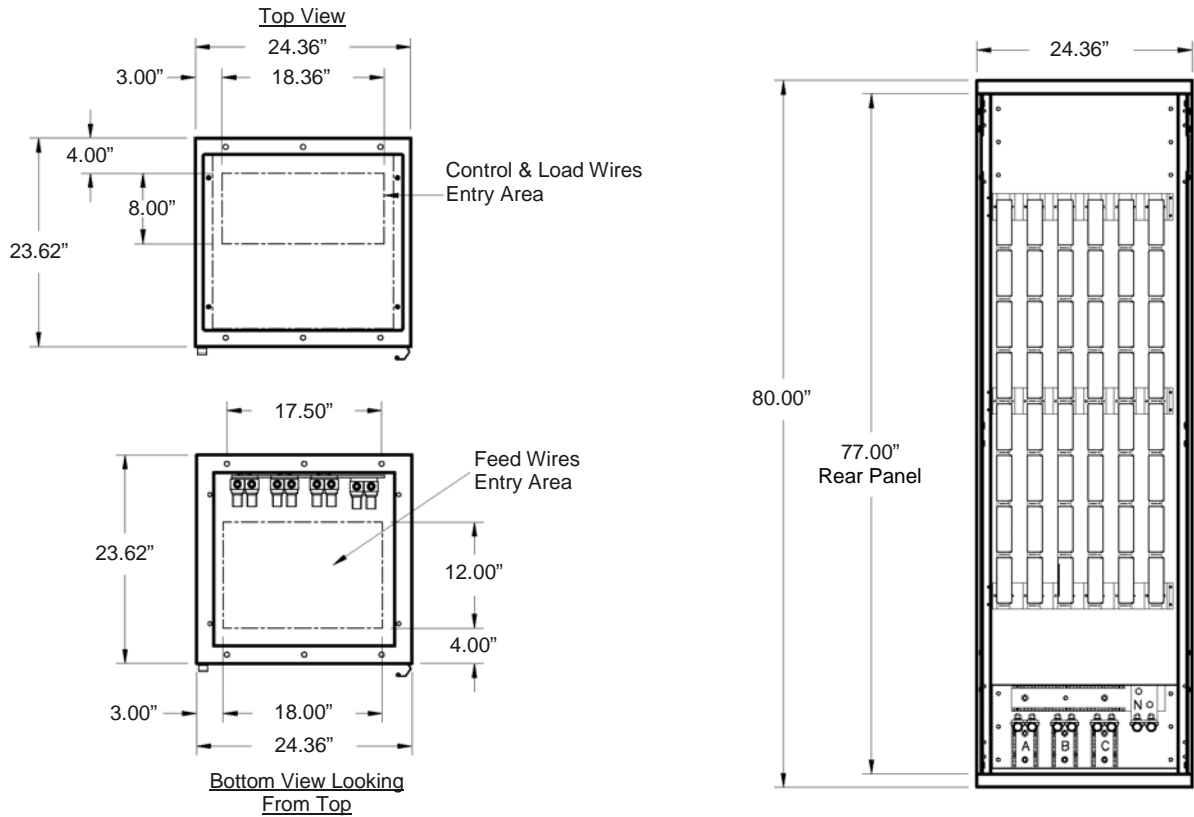

Figure 9: Mounting Dimensions

**Notes:**

The dimmer rack must be placed on a non-combustible floor.

Installing the dimmer rack on a low concrete pad (or housekeeping pad, per the NEC) added on top of the floor is recommended to keep the dimmer rack clear of incidental water or accidental flooding.

Allow adequate clearance at the front of the dimmer racks for them to be opened for wiring purposes and safe servicing.

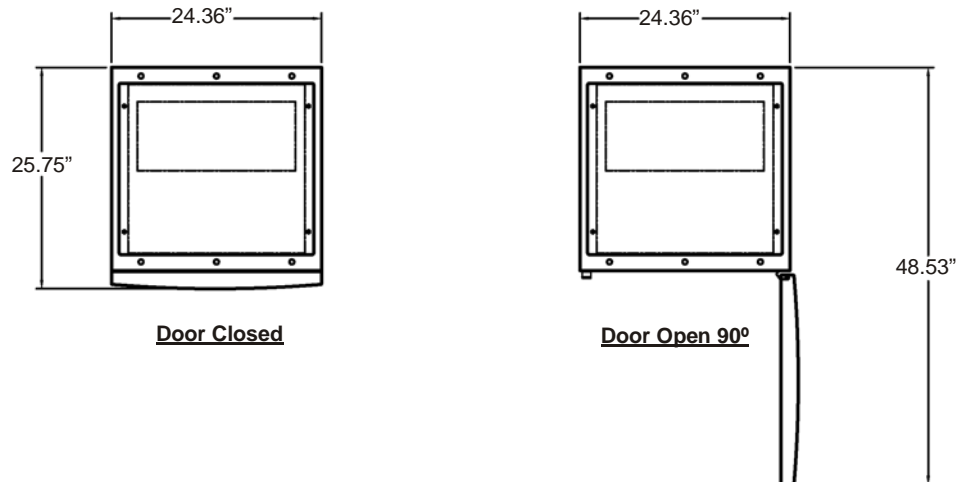

Figure 10: Clearances

## 4. Preparing the Rack for Wiring

The C21 dimmer rack is supplied without the door installed. The dimmer modules and rack processor housing are supplied separately.

**In order to gain full access to the rack, you must:**

- Step 1. Remove the top and bottom grills.
- Step 2. Remove the thermostat "L" bracket assembly from the top cover plate. *Be careful not to damage the thermostat. A damaged or broken thermostat will render the dimmer rack inoperable.*
- Step 3. Remove the eight dimmer trays.
- Step 4. Remove the fan housing.



### WARNINGS!

- **Do not** remove the door from its carton.
- **Do not** install the dimmer rack door. This will be installed by a Strand Lighting Engineer or an Authorized Service Center Technician as part of the system commissioning.

## 5. Locating Dimmer Components

The following drawing shows the location of rack components.

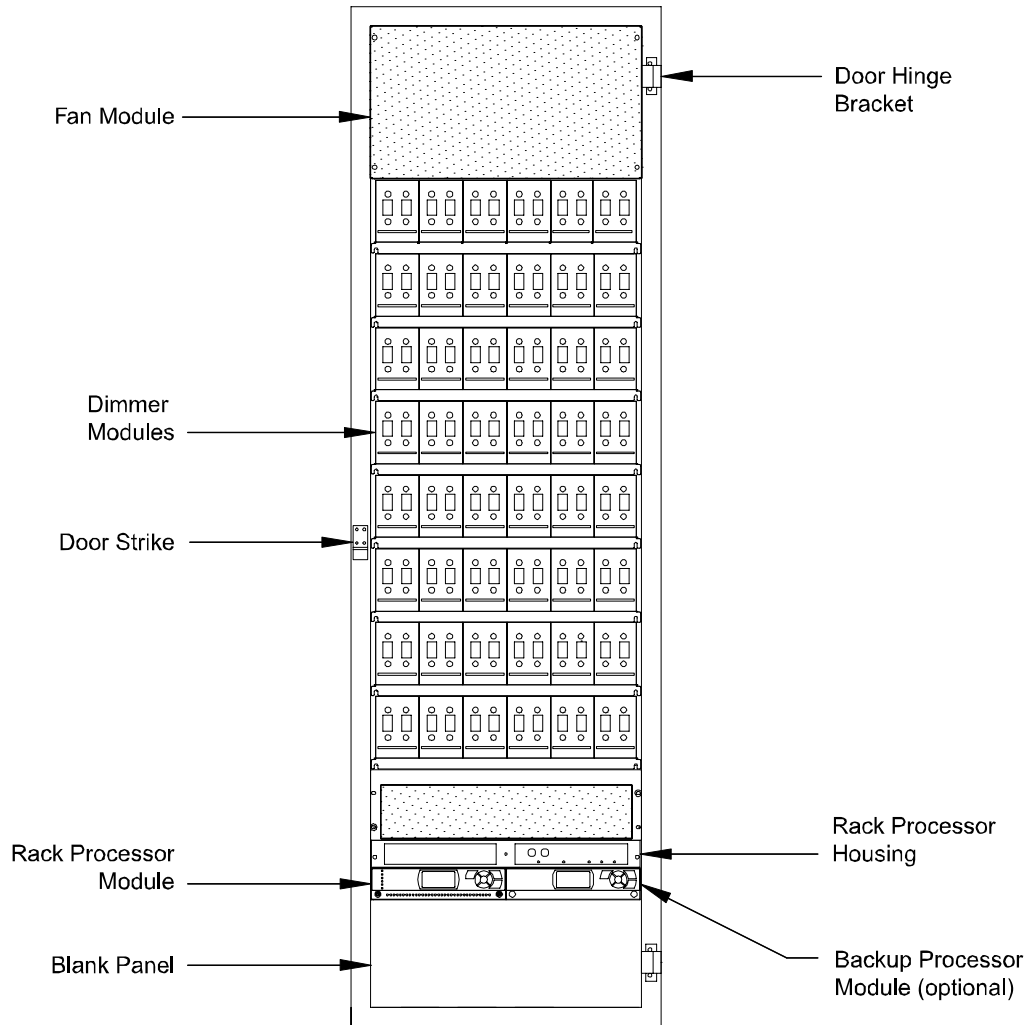
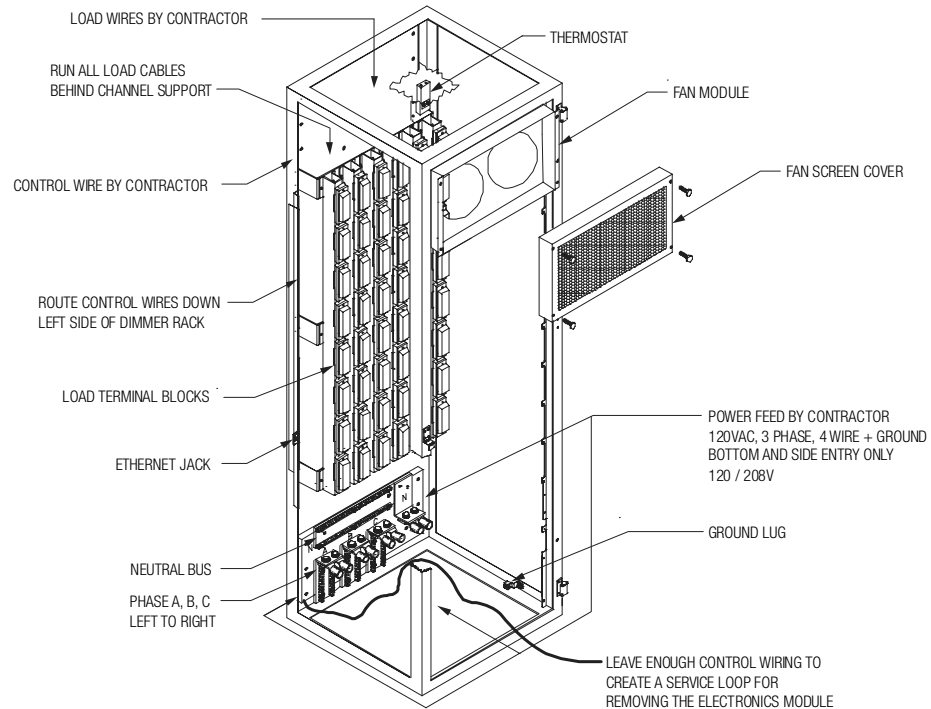

Figure 11: C21 Dimmer Rack (door removed for clarity)

## 6. Power Wiring

Power feed wiring can be from either the bottom or bottom sides of the dimmer rack. The phase, neutral and ground power cables enter the rack through the bottom. All power cables are terminated using a suitable-rated compression lug and bolted to the mains bus bars.



**Figure 12: Bus Bar Connections Behind Processor Assembly (bottom entry shown)**

Connect all external power feed wiring to the dimmer rack. Internal power wiring between dimmer rack components is pre-wired at the factory.

(2) 500 kcmil compression lugs are provided per phase and neutral bus. A ground lug is provided for earth ground connections



**CAUTION:** These lugs are UL Rated for copper conductors only.

- Step 1. Connect system ground to the ground lug provided.
- Step 2. Connect the neutral to the neutral bus bar.
- Step 3. Connect the power feeder wires to the mains bus bars.

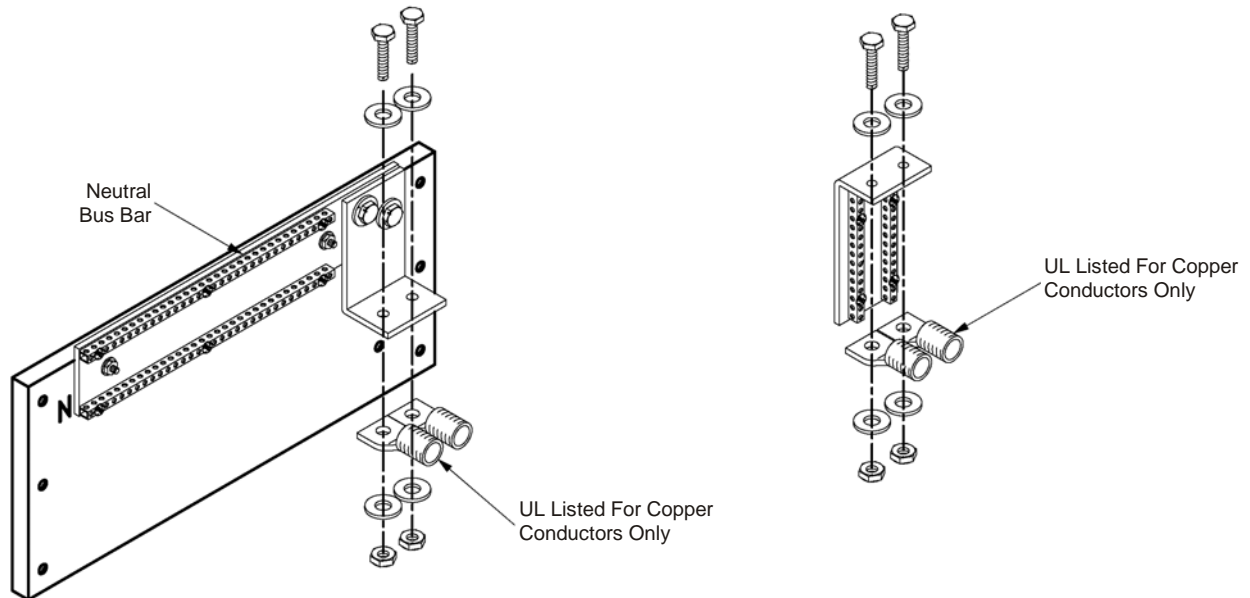

Figure 13: Compression Fittings Detail

---

#### Notes:

- This equipment is intended to be installed in accordance with the National Electric Code, ANSI/NFPA 70-2002, or the Canadian Electric Code, Part 1.
  - C21 dimmer racks installed in Canada shall select wire size with 75 degree centigrade rating from table 2 or 4 of the Canadian Electrical Code, Part 1.
  - C21 dimmer racks intended for use aboard Marine Vessels over 65 feet shall be subject to the requirements of the USCG Electrical Engineering Regulations, subchapter J (46 CFR Part 110-1131).
-

## 7. Dimmer Rack Bussing

Inter-Rack Bussing Kits can be used to interconnect the supply bus bars between adjacent C21 dimmer racks.

Three bussing kits are available:

Part #	Description
76680	800A bus kit
76681	1600A bus kit
76682	2400A bus kit

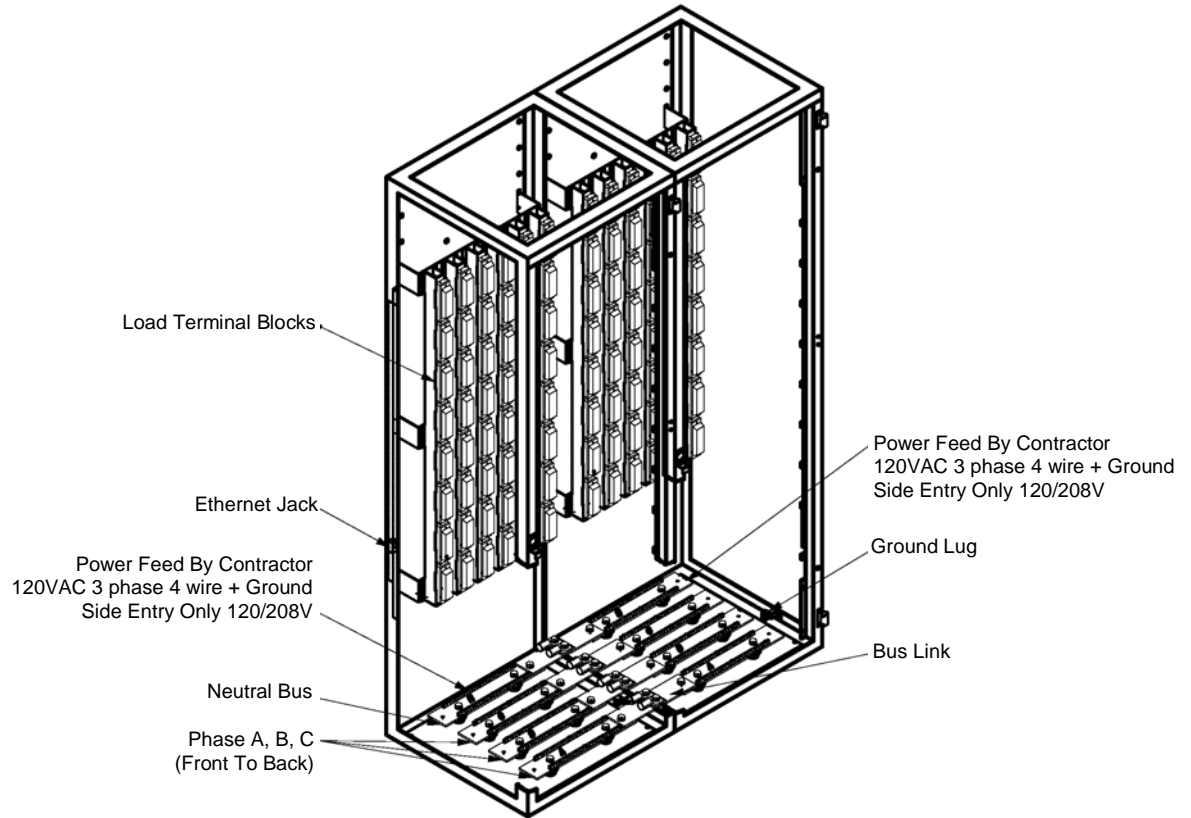

Figure 14: Bottom Bus Racks

## 8. Load Wiring

Load wiring is connected directly to the dimmer receptacle. Wires can be routed down channels next to the dimmer receptacles so that they are out of the way once the rack is assembled.



**CAUTION:** Only hook up AC lighting loads to this equipment.

Connect load wiring according to your system drawings. Set screws in the dimmer receptacles require a standard 1/8" Allen wrench.

Neutral wires for the 100A receptacles terminate on the neutral bus bar located at the top of the dimmer rack.

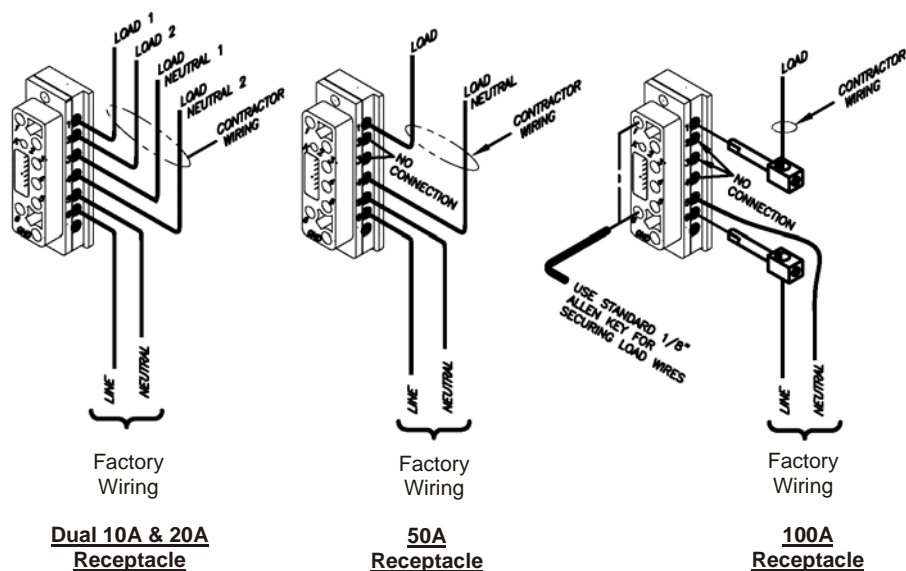

Figure 15: C21 Dimmer Receptacles

### Dimmer connector load and neutral pins:

- Screw type: 1/4-20 brass
- Wire gauge range: 14-6AWG
- Maximum screw torque setting: 56 inch lbs.
- 100 amp Adaptor
- Wire gauge range: 4-2AWG
- Maximum screw torque setting: 20 inch lbs.

### Earth bus connections:

- Screw type: 1/4-28 brass
- Wire gauge range: 14-6AWG
- Maximum screw torque setting: 70 inch lbs.

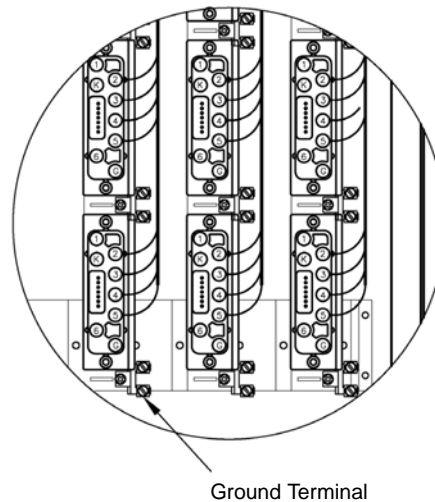

Figure 16: C21 Load Ground Terminals



## 9. Control Wiring

Control wiring between dimmer rack components is pre-wired at the factory. Connections that go to the control interconnection card (CIC) are in a bundle and clearly labeled.

## 10. Install the Rack Processor Housing

**To install the Rack Processor Housing (RPH) in the dimmer rack:**

- Step 1. Remove the cover from the cable chute on the left side of the rack by putting your fingers in the gripper holes and pulling up.
- Step 2. Run all control cables down the cable chute.
- Step 3. Punch down the Ethernet cable, if applicable.
- Step 4. Replace the cable chute cover.
- Step 5. Slide the electronics chassis into the rack.
- Step 6. Connect the cables from the rack to the appropriate plugs on the CIC.
- Step 7. Slide the electronics chassis back out of the rack until it just barely rests in its slide brackets.
- Step 8. Make all control connections with the electronics chassis in this position.



**CAUTION:** Make sure that there is enough wire in a service loop for you to take the electronics module completely out of the rack and put it on the floor if necessary without disconnecting any of the contractor control wiring.

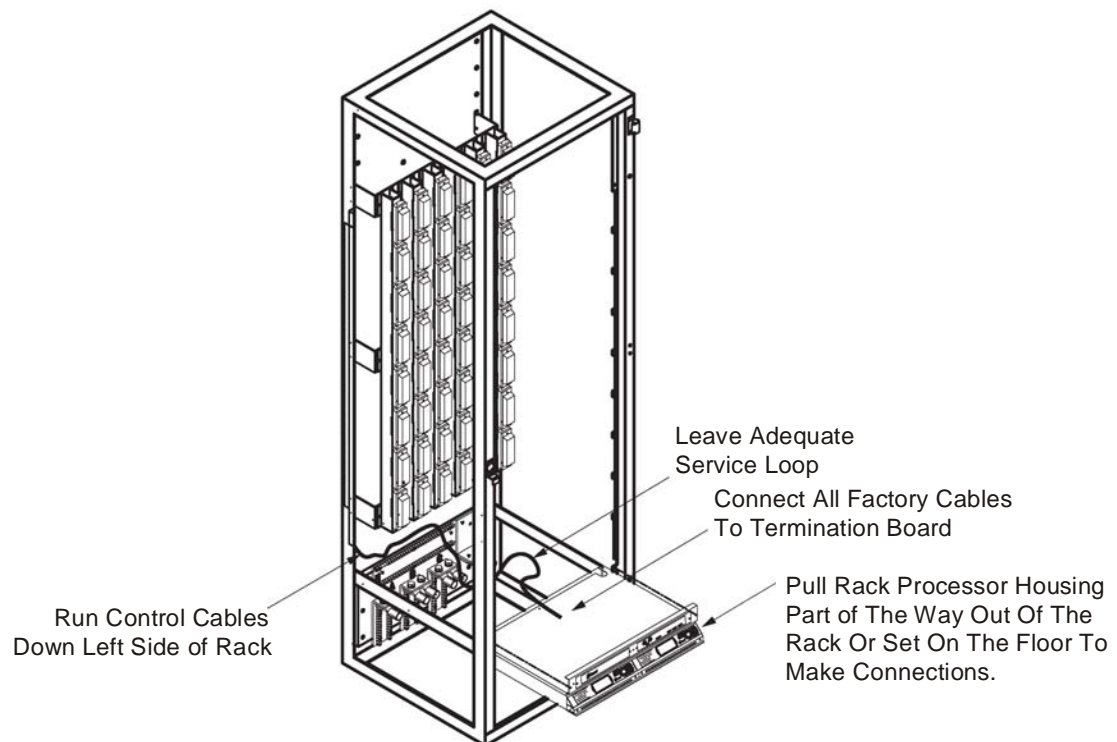

Figure 17: Install Electronics Chassis

## Connecting Power to the Rack Processor Housing

The three-phase supply to the rack processor housing (RPH) is factory wired from a terminal block at the bottom rear of the rack. The cable is connected to the rack processor housing by a multi-pin plug located on the rear of the housing. Sufficient cable length is allowed to permit the rack processor housing to be removed for servicing. Insert the plug into the socket on the rear of the rack processor housing.

Secure the rack processor housing in position using the screws supplied. Check that the appropriate fuses are fitted into the fuse block located at the bottom rear of the dimmer rack (three 8A fuses).

Some dimmer racks will contain an additional fuse block for optional emergency transfer panels. Review the Strand Lighting system riser diagram for connection details if this additional fuse block has been supplied.

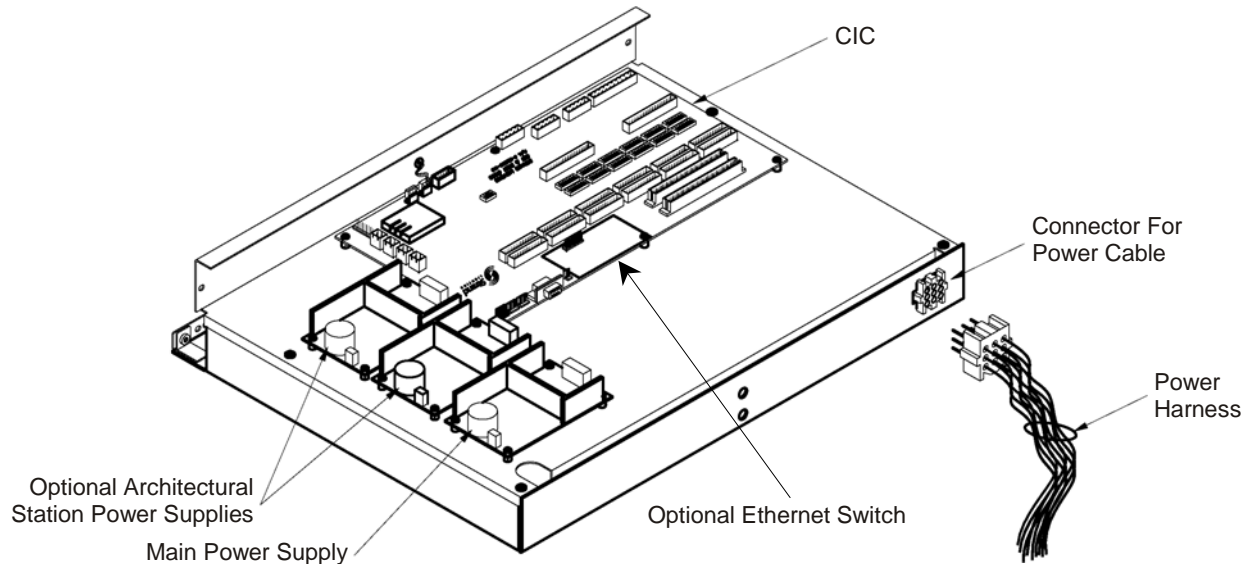

**Figure 18: Connecting Power to the Rack Processor Housing (RPH)**

## 11. Connecting the Dimmer Control Cable Harness

Connect the dimmer control cable harnesses to the Control Interconnection Card (CIC) located on the top of the rack processor housing. The dimmer control cable harnesses are factory wired to the dimmer slots and plug into their dedicated connection point on the CIC. Uncoil the dimmer control cable harnesses marked 'T1' through 'T6' and 'B1' through 'B6' and connect them to the CIC board.

## 12. Connecting the Control Signal Wiring

C21 dimmer racks accept a variety of data signals as inputs and outputs and provide control signals to the dimmers in the rack, together with status signals. All contractor control signal wiring is connected to the control interconnection (CIC) card located on the top of the rack processor housing (RPH) with the exception of the Ethernet cable that is terminated at the upper left rear of the rack. All external control wiring is run in the wire trough mounted at the rear left-hand side of the rack. Connect the Ethernet cable (supplied) to the RJ45 connector mounted on the cable trough located at the rear-left of the dimmer rack.

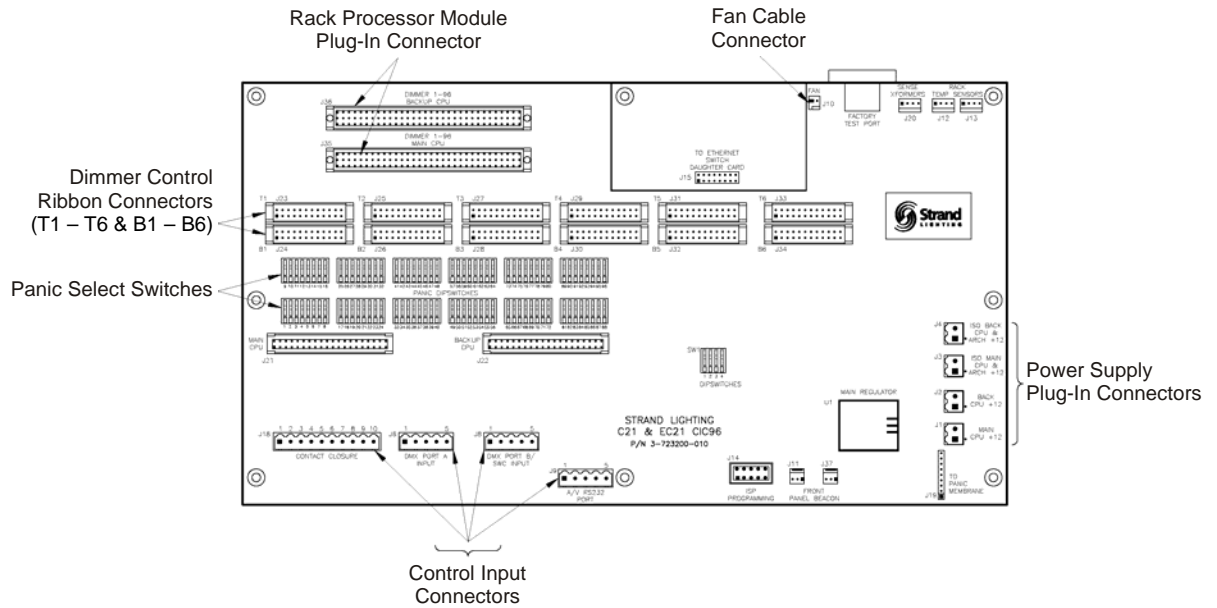

Figure 19: Connecting Control Signal Wiring

### Control Cable Routing

A cable trough is provided in the top left hand side of the rack for the control cables. Control cables should be fed through the access holes provided in the top of the rack and run down the trough until they reach the processor area. The trough can be removed for easy access.

### Ethernet Control Wiring

The Ethernet control cable will terminate to the Ethernet jack located in the wireway cover at the left-rear of the dimmer rack. The terminations are to be made using the TIA/EIA standards. Terminations are to be made using the 568B color code.

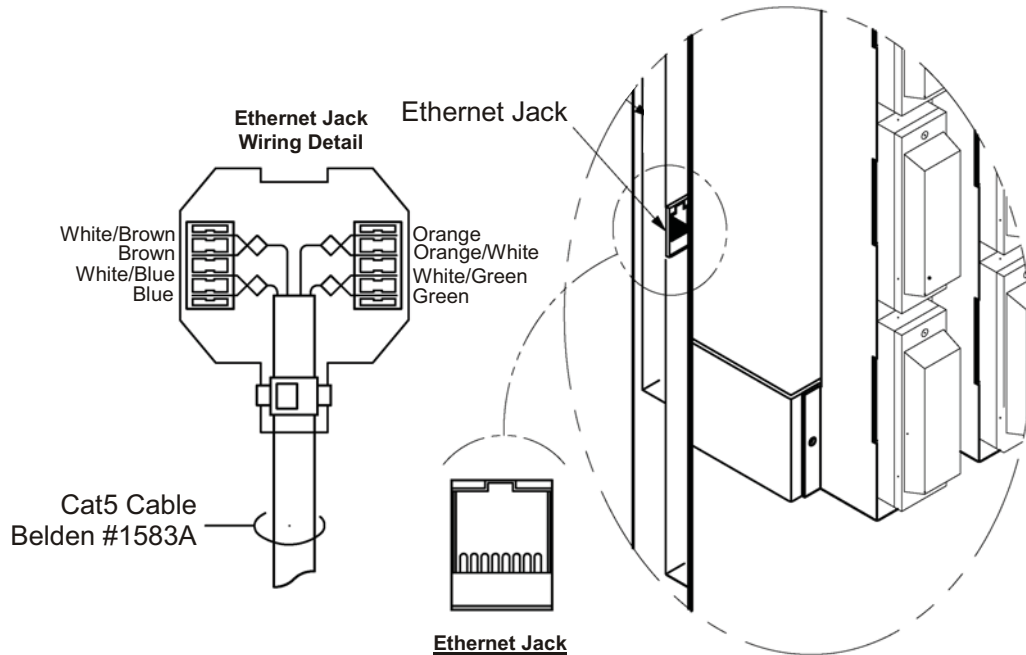

Figure 20: Ethernet Wiring and Termination

Cable:		Belden 1583A or Strand Lighting approved equal.			
Max Length: 300 Ft.		This cable must be installed and terminated in compliance with TIA/EIA-568 standards for Category 5 cabling. Terminations are to be made using the 568B color code.			
Connector: 8-Pin RJ45					
RJ45 Pin #	Terminal number	Ethernet Signal	Comments	Pairs	Wire Color
1	1	TX+		2	White/Orange
2	2	TX-		2	Orange/White
3	3	RX+		3	White/Green
4	4	N/C		1	Blue/White
5	5	N/C		1	White/Blue
6	6	RX-		3	Green/White
7	7	N/C		4	White/Brown
8	8	N/C		4	Brown/White

Table 1: Ethernet Termination

### DMX512 Wiring

The two types of connections provided in Strand Lighting equipment for DMX512 dimmer control signals are the XLR style connector and terminal blocks. C21 dimmer racks use pluggable terminal block connections. Wall receptacles and consoles use XLR style connectors.

In systems that use DMX512 control wiring, the DMX512 signal is terminated at the first rack and then re-transmitted to the other dimmer racks over the Ethernet network.

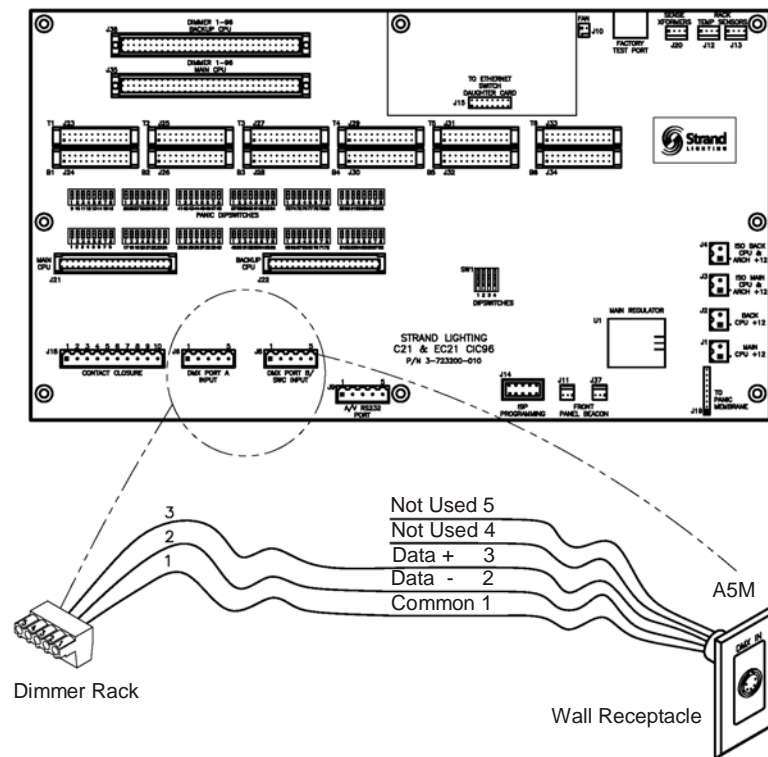

Figure 21: DMX512 Wiring and Termination

Cable:	Belden 9829 or Strand Lighting approved equal.				
Max Length: 1000 Ft. (300m)	Standard RS485 electrical characteristics apply, including line driver and receiver characteristics, line loading, and multi-drop configurations.				
Connector: 5-Pin	Pluggable (two-piece) screw terminal block in rack, labeled DMX512 Port A and DMX512 Port B/SWC Input. "XLR" style connectors in wall boxes and on control consoles.				
XLR Pin #	Terminal number	DMX512 Signal	Comments	Pairs	Wire Color
1	1	COMMON	Dimmer Common (Shield)		Shield
2	2	DATA1 -	Dimmer Drive Complement	Pair 1	White/Blue
3	3	DATA1 +	Dimmer Drive True	Pair 1	Blue/White
4	4	--	--	Pair 2	White/Orange
5	5	--	--	Pair 2	Orange/White

Table 2: DMX512 Termination

### SWC/Outlook Control Wiring

Control wiring from SWC hand held controllers and stations such as Outlook is connected to the SWC/DIGITAL NETWORK connector on the CIC. Wiring instructions and appropriate wire gauge sizes are provided on the system riser diagram.

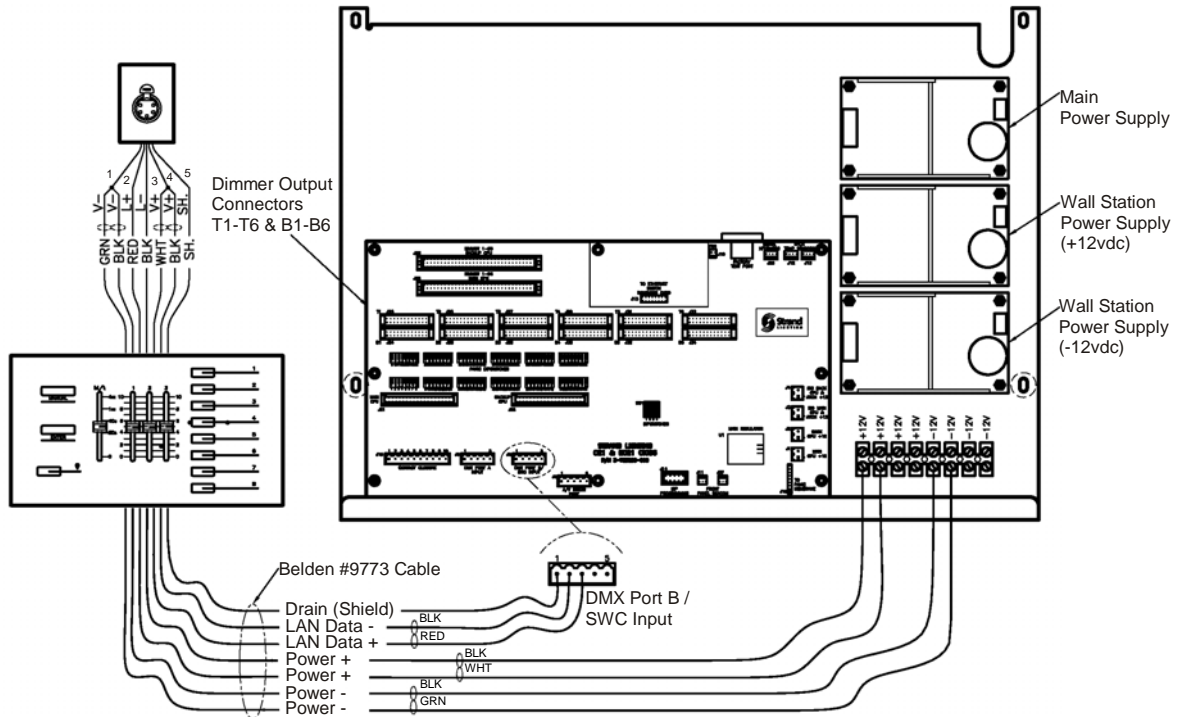

Figure 22: SWC/Outlook Wiring and Termination

Cable:		Belden 9773 or Strand Lighting approved equal.				
Max Length:		1000 feet (300m - daisy chained runs only).				
Connector:		Pluggable (two-piece) screw terminal block in rack, labeled DMX512 Port B/SWC Input. Pluggable (two-piece) screw terminal block on stations.				
XLR Pin #	Rack Term #	Station Terminal Label	Signal Name	Comments	Belden 9773 Pairs	Cable Color
--		---	GND	Ground		
3	2	L-	LAN Data -	Network Signal Compliment	Pair 1	Black
2	3	L+	LAN Data +	Network Signal True	Pair 1	Red
5	1	Screen	SHIELD	(3) Drain Wires	Drain	(3) Drains
4	T.B.	V+	V+	+12VDC	Pair 2	White/Black
1	T.B.	V-	V-	-12VDC	Pair 3	Green/Black

T.B.=Terminal Block

Table 3: SWC/Outlook Termination

**Notes:**

- Wherever possible, control station runs should be single pulls directly from the first control station in a daisy-chained run.
- Do not cut the control cable at junction or pull boxes. The control cable must be a continuous run from the rack to the wall stations.
- If connections must be made in a junction box due to length of run or other considerations, these connections must be soldered before installation of the wire crimp. These are not power connections. They are electronic interconnections that feed data directly to a microprocessor in the processor module. Poor connections may cause problems by introducing electronic noise into the system, resulting in poor system operation.

**Remote Contact Closure Connections**

You can connect several other external contacts for controlling rack functions. These functions are then available remotely and instantly.

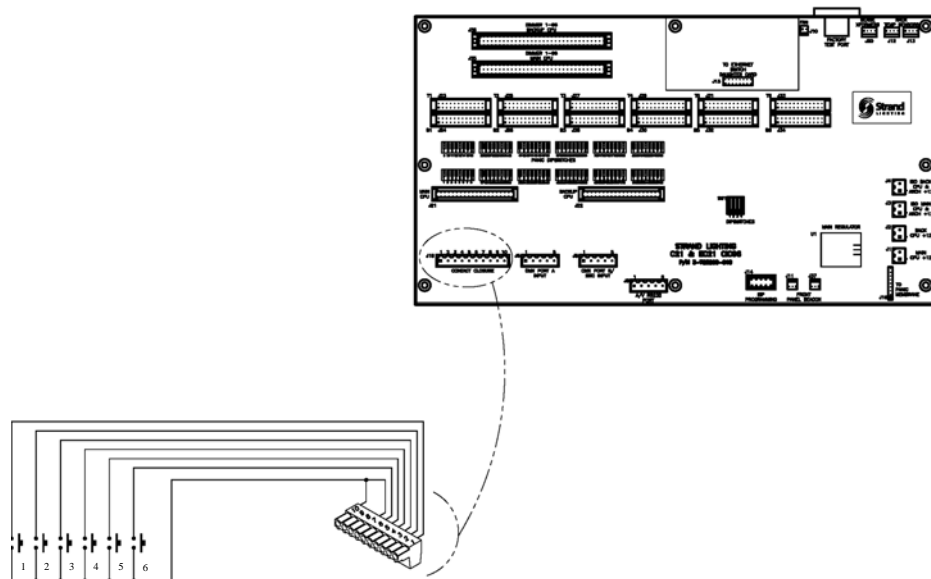

**Figure 23: Remote Contact Closure Termination**

Connector:		Pluggable (two-piece) screw terminal block in rack, labeled Contact Closure.	
Pin	Function	Type	Description
1	PANIC ON	Momentary	Turns Panic On
2	PANIC OFF	Momentary	Turns Panic Off
3	FIRE ALARM	Maintained	Turns Panic On, No Override
4	SWC PRESET 1	Momentary	Fires SWC Preset 1
5	GO NEXT SWC	Momentary	Fires "Next" SWC Preset
6	GO SWC OFF	Momentary	Fires SWC Preset 0 (Blackout)
7	COM/GND		COM/GND
8	OPEN		OUTPUT 1
9	OPEN		OUTPUT 2
10	COM/GND		COM/GND

**Table 4: Remote Contact Closure Termination**

### RS232 Interface

The RS232 Interface allows for third-party A/V systems to directly recall any of the 128 SWC presets that are stored in the local rack processor housing (RPH) using serial commands.

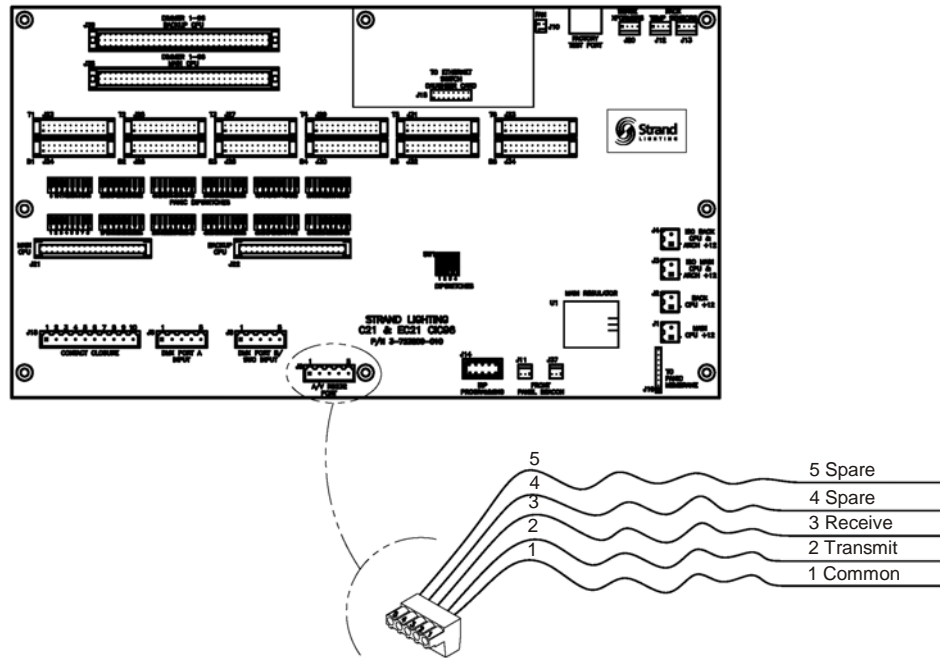

Figure 24: A/V Interface Termination

Connector:	Pluggable (two-piece) screw terminal block in rack, labeled A/V Interface Port
Pin	Function
1	COMMON
2	TRANSMIT - TX
3	RECEIVE - RX
4	SPARE
5	SPARE

Table 5: RS-232 A/V Interface Termination



### Select Dimmers for Panic

Panic turns any single dimmer, combination of dimmers, or all dimmers ON, bypassing system electronics.

Select panic for a dimmer using DIP switches located on the CIC. Each rack has 96 panic switches.

Dimmers with switches ON are switched ON when you activate panic, regardless of their control station settings. Dimmers with panic select switches OFF are not affected when panic is activated. Racks are shipped with all switches OFF.

#### To activate panic:

- Step 1. Press the PANIC ON button located on the front of the rack processor housing (RPH) to turn panic ON.
- Step 2. If you have a remote PANIC station, press the PANIC ON button to turn selected dimmers in the rack ON.

#### To deactivate panic:

- Step 1. Press the PANIC OFF button located on the front of the rack processor housing (RPH) to turn panic OFF. Pressing the PANIC OFF button returns the dimmers to a NORMAL control state.
- Step 2. If you have a remote PANIC station, press the PANIC OFF button to turn selected dimmers in the rack OFF. Pressing the PANIC OFF button returns the dimmers to a NORMAL control state.

## 13. Installing the Door

The locking door for the rack ships from the factory in a separate box.

#### To install the door:

- Step 1. Remove the door and hardware from the box.
- Step 2. Install the hinge plates on the right or left side of the rack.
- Step 3. Install the door strike on the opposite side of the hinge plate.
- Step 4. Align the door to the hinges.
- Step 5. Install the hinge pins to the door.
- Step 6. Install the Strand Lighting nameplate to the center of the door.

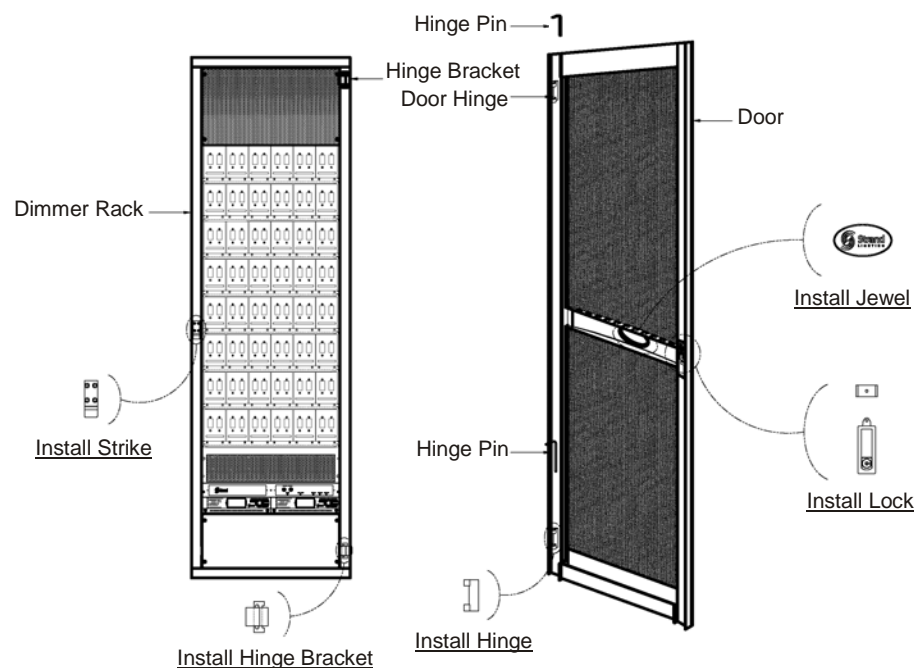

Figure 25: Installing C21 Rack Hinge Plate and Door

# COMMISSIONING

## 1. Safety Check

Before applying power to the system you should double-check all of your wiring.

- Step 1. Check that all terminals, screws, and bolts are secure and tightened according to the torque setting.
- Step 2. Check for stray wire strands and make sure wires are correctly restrained and not in contact with metal edges or obstructing the dimmer module ventilation paths.
- Step 3. Check earth ground connections.
- Step 4. Double-check neutral connections and positively verify phase orientation at the input bus bars. Ensure that neutral has not been confused with a phase - connecting the unit "across the phases" will do severe damage.
- Step 5. Make a full safety inspection of all load wiring.

## 2. Initial Power Up

Systems purchased without Field Service commissioning are now ready for system power. For such systems, follow the steps below. If commissioning is required, a notice appears on the riser diagram that the system should not be energized without a factory technician present. Call and request scheduling for commissioning as early as possible. Due to heavy scheduling requirements, the minimum time required for proper scheduling is two weeks.

- Step 1. Make sure the incoming power is correctly rated per system riser. If not, correct before proceeding.
- Step 2. Make sure the control input signals to the dimmer racks are off.
- Step 3. Apply power to the system.
- Step 4. Check that there are no lights on.
- Step 5. Turn off main power to the rack and insert the rack processor module (and backup processor, if supplied).
- Step 6. Turn on power to the rack.

If the system does not function properly, follow the troubleshooting instructions in the C21/EC21 Operation Guide. If these steps fail, or for assistance with replacement parts, please call Strand Lighting or the local Authorized Service Center in your area.

## 3. Processor Self Test and Fault Identification

Once you have applied power you need to make sure that the system is working correctly and the rack processor modules are set properly for the installation. This step checks for any problems due to shipping or installation.

When the rack is switched ON, a number of self-tests are run. If no faults are detected, the system displays the default message as shown:

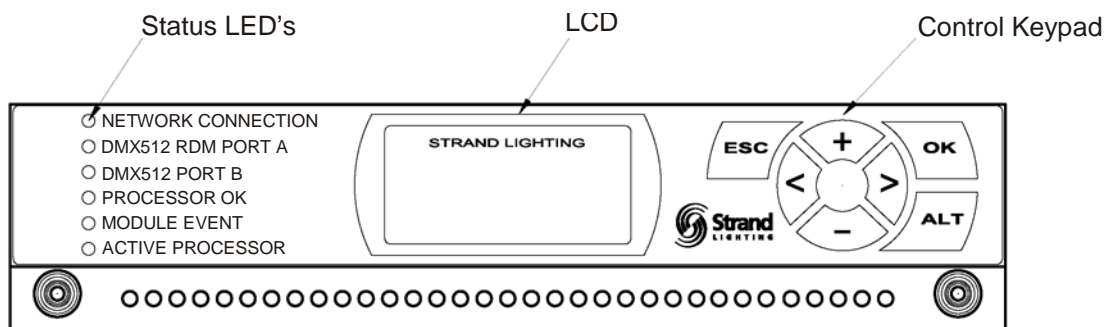

Figure 26: Rack Processor Module (RCM) Front Panel

## 4. Rack Processor Housing LEDs

### LED Status

The LEDs on the front of each rack processor module are the first level of diagnostics and provide immediate visual status indication. The nine LEDs on the front of the rack processor housing and module indicate the following:

Phase A (green): Should be ON if Phase 1 is OK.

Phase B (green): Should be ON if Phase 2 is OK.

Phase C (green): Should be ON if Phase 3 is OK.

Over-Temp (red): Should be OFF. Flashing indicates an Over-Temp condition. ON indicates dimmer module automatic Over-Temp shutdown.

Panic (red): Should be OFF. On indicates that PANIC has been activated.

Lighthouse (blue): Blue = normal. Flashing red = error. Solid red = shutdown.

### Rack Processor Module LEDs

Network Connection (green): Should be ON if there is a network signal.

DMX512 A (green): Should be ON if there is a DMX512 signal.

DMX512 B (green): Should be ON if there is a DMX512 signal.

Module Event (red): Should be OFF. On indicates a dimmer fault

Processor OK (green): Should be ON. Off indicates there is a problem.

Active Processor (green): Should be ON if self-test is OK. Indicates active processor.

### Dimmer Events

If the Module Event LED is on, the LCD will show the number of dimmer events and will automatically scroll the display to show a description of the event(s) Refer to the C21/EC21 Operation Guide for a description of event codes. If any other LED does not illuminate correctly, switch OFF the power immediately and check the installation again. If the fault persists and all wiring seems correct, call Strand Lighting.

If the LCD shows an error, see the Error Log section of the C21/EC21 Operation Guide.

## 5. Output Check

Gradually increase the control signal to each dimmer in turn from 0% to 100% using the SET LEVEL function and carefully monitor the loads. Check for any error messages, or dimmer events displayed on the rack processor module LCD.

## 6. Initial Programming

Refer to the C21/EC21 Operation Guide and set the following menu items, as applicable:

- Language
- Rack number (if applicable)
- Fan Speed Control
- LCD Contrast
- Time and date

Other items you may wish to set at this time, depending on your system configuration, are:

- DMX512 patch
- DMX512 Mode
- Outlook patch
- Max Voltage
- Min Level
- Circuit ID Start
- Circuit ID Patch
- Dimmer Response
- Dimmer Profiles
- No DMX512 Preset or Hold condition.
- Power Up Preset

## 7. Programming and Fault-Finding

Refer to the C21/EC21 Operation Guide supplied with the dimmer rack for Basic Troubleshooting instructions and details on how to use the rack processor module keypad and LCD display to program all the functions of the C21 dimmers.

## Notes

## Notes

## Notes

**PHILIPS**

# Strand Lighting

Strand Lighting  
Dallas  
10911 Petal Street  
Dallas, TX 75238  
Tel: +1 214-647-7880  
Fax: +1 214-647-8031

Strand Lighting  
New York  
267 5th Ave, 4th Floor  
New York, NY 10016  
Tel: +1 212-213-8219  
Fax: +1 212-532-2593

Strand Lighting Asia Limited  
Unit C, 14/F, Roxy Industrial Centre  
No. 41-49 Kwai Cheong Road  
Kwai Chung, N.T., Hong Kong  
Tel: +852 2796 9786  
Fax: +852 2798 6545

Strand Selecon  
Auckland  
19-21 Kawana Street  
Northcote, Auckland 0627  
New Zealand  
Tel: +64 9 481 0100  
Fax: +64 9 481 0101

Strand Lighting  
Europe  
Rondweg zuid 85  
Winterswijk 7102 JD  
The Netherlands  
Tel: +31 (0) 543-542516

[www.strandlighting.com](http://www.strandlighting.com)

Part No: 2-450173-040 (Rev. A)

©2013 Philips Group