

TABS

December 1971 Vol. 29 No. 4

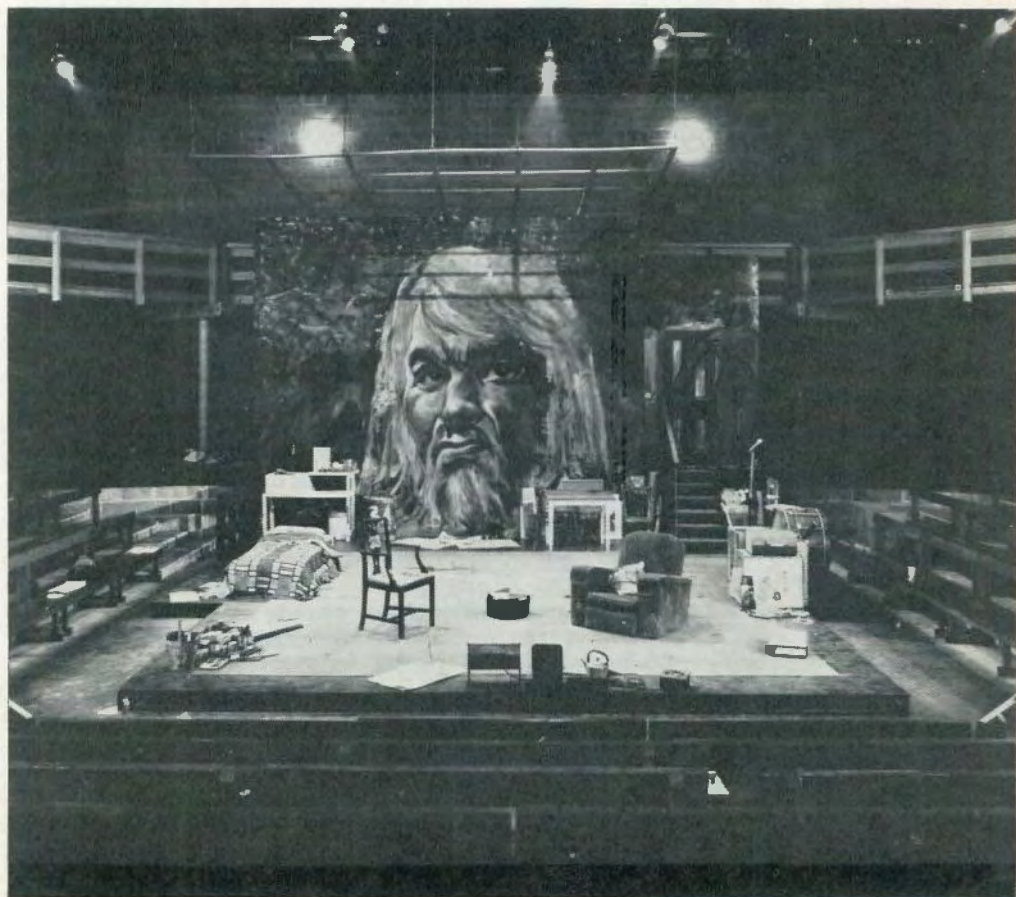

TABS

Published by
Rank Strand Electric Limited
29 King Street, Covent Garden,
London WC2E 8JH

Editor: Frederick Bentham

December 1971 Vol. 29 No. 4

Editorial

Stalling or Immobility	111
The Scarecrow or a Scaley Problem	112
Gunnersbury 1932-1971	113
Triptych by Frederick Bentham	114
Cutting your shape to suit your show <i>by Barbara Berrington</i>	125
MacRobert and Brunton by Francis Reid	130
Slight on Stage Lighting	136
DDM—A Revolution in Lighting Control by David Baker	139
Pre-set Spots and Other Irregularities	148
Correspondence	150
Synopses	152
Rank Strand on the Move	152

Cover picture: Little Malcolm and his Struggle against the Eunuchs. The Young Vic.

Stalling or Immobility

It has suddenly become *de rigueur* to have a lighting control in the stalls for rehearsal purposes, and a number of first-class installations either have it or are about to have it. As in so many things to do with stage lighting we have but to turn up earlier writings to find ourselves fervently advocating such a technique. Furthermore, we are glad to say that, being us, it was not all talk—there were the technical means to do so. Indeed the 216-way Light Console in Drury Lane Theatre has, coiled up beneath, sufficient flexible cable to allow it to be moved out into the stalls for rehearsal. Installed twenty years or so ago, the console has in fact never been moved out there—not even for the month-long lighting rehearsals for the much-heralded *My Fair Lady*.

There were other such installations. For example, a certain work¹ declared of the Light Console in the Theatre Royal, Bristol, that it “can be moved and plugged up in the stalls for rehearsals”. The same book shows a photograph of a portable 64-way light-control desk used in the South Shore Blackpool Icedrome at about the same time. Here, “detachable plugs allow the desk to be used in four positions, one of which is 300 feet from the dimmer bank”. This was again for rehearsal purposes so that the operator could see what he was doing. From then on the battle was waged, and often won, to obtain a good front-of-house position, and now such a requirement would not be questioned.

Yet at this very time when excellent F.O.H. positions have become available, many of them quite perfect, the call goes up for a temporary position in the stalls. Whence springs this demand? We suspect that the blame lies with Francis Reid. He started a fashion at Glyndebourne which was perfectly logical there but which will not bear examination everywhere, and before *everyone* jumps on this band wagon we shall set out to tell you why.

Francis Reid had planned that control for limited festival seasons, during which he

not only lit the shows but was also the principal operator during performances. What could have been more logical than to have, as he did in effect, a complete preset down in the stalls and a duplicate set of operational masters². Some or all channels could be transferred. Thus he could compose the picture from down below next to the Director or take over bits and modify while his assistant operator remained on the main board. A couple of years later a rather similar installation went into the National Theatre where the resident operators remained on the main control, while in the stalls Richard Pilbrow and other visiting lighting designers could tweak and modify their lighting directly themselves in order to get exactly what they wanted. These two were “enstalled” in 1964 and 1966 before the days of instant dimmer memory (i.e. magnetic plotting).

Everything had to be written down. The plot, whether it was being written down or read back for execution, was the big bugbear. It was that more than anything else which made intervention by the director or the lighting designer at a critical moment such a something nuisance. When about to put into action an unfamiliar, scribbled lighting change—the means for achieving which he had scarcely worked out—there was a temptation for the operator to be rather sharp with the most modest request.

Nevertheless there were and are a number of operators who seemed to thrive on such a diet at rehearsals and who take everything in their stride. The more preposterous the demands and the more limited the switchboard, the greater the virtuosity and the better the service.

We now seem about to throw all this away. We collect together every facility man can devise to make the operator's lot easy, we place him in a good position to see the

¹“*Stage Lighting*”, by Frederick Bentham, Pitman, 1950.

²TABS. Vol. 22, No. 2. June 1964.

stage and then deprive him of his hour of glory—the hour of challenge. What damn fools we mortals be! No one tries to work out the qualities of a good operator—what it is that attracted him to this work.

More and more as we get involved in advanced—and this means really advanced—switchboards one becomes convinced that working such a control needs to be fun. For what shall it profit a man, if he shall gain the whole control, and lose the operator's soul? A superb switchboard

demands a superb operator. In the kind of theatre that is spending money like this it will still be the fingers of the lighting operator even if used only one at a time which will breathe life into the visual side of the show. There are some who see the modern switchboard as something that needs to be jerked into action by signals from the stage manager in the prompt corner—now perfectly possible.

Of course, if you see the lighting role like that. . . .

The scarecrow or a scaley problem

Between ourselves and Covent Garden Tube Station, or Opera House according to need, there are some grimy steps leading to what can best be described as “the regions below”. It is, rumour has it, some sort of club. It can't be a discotheque because guitars and other stringed machines and their electronic attachments can be seen moving up and down the steps. Not of their own volition—for although they are assigned legendary powers to stun humans into voluntary and involuntary movement they are themselves deprived of self locomotion. It may be that one day the electronic guitar and the motor car will interbreed—a case of “The Day of the Guitos” when Kraken will assuredly awake.

We return to a lone figure standing by the cellar steps. This came straight out of Dickens, design by Cruickshank, costume by any Old Curiosity Shop. Passing “it” by (there were no pointers to sex) at close range there were no indications that the object was other than perfectly clean—much cleaner be it said than many a spruce young City gent in his sweated black coat! The truth is that the rags and tatters were just so much decor, a kind of put-up job.

And thus it is with so many places where it is good to eat and to fun. Likely enough nowadays if someone describes a splendid meal or show they begin by detailing how they crept down some ill-lit back alley, picked their way past ageing and crammed refuse bins to pass through a

door half-off its hinges into a smoke-filled candlelit den. Candlelit did we say—well, the last time we dined in such a place in Chelsea we had to call for a second candle before we could discern where among the obfuscations to poke the knife and fork. This second “luminaire” was obtained promptly from off an adjacent table by the waiter, or rather by the youth in shirt-sleeves and skin-tight trousers. Strangely when another party entered later and took possession of their table it evidently did not occur to them that they needed any light at all.

And the food? Well, it was marvellous—at any rate it tasted marvellous—and all the distant guitar plonkings quite failed to curdle the taste buds.

It is curious indeed that at the very time when smart or anyway smart-appearing décor is eschewed elsewhere, civic authority is frantically building Palaces for Theatre, and even elderly theatres are being given a facelift with new coats of paint. It is yet more curious that those in the know at the receiving end are not all that keen on palaces and it is those-in-the-know that constitute many of the people that go to theatre.

Of course, every palace has to have its “studio theatre”. No theatre worthy of the name can afford to be without one! Hastily contrived and shoved in any left-over space these are, so it is said, the true nests of vital theatre. Decide however that you want one well in advance, carefully plan a

building for the purpose and what do you find? A number of universities provide the awesome answer—lots of architecture and lots of equipment. In such mini-palaces trained custodians are necessary and inevitably restrictions appear. Makeshift and improvisation sit strangely among the Guitos. Surely the main stimulus in adventure playhouses comes from the frustrations and restrictions, from imaginative leaps and wriggles past the obstacles

Gunnersbury 1932-1971

Who was Gunnersbury? it may be asked. More correctly it should be, "What was . . ." because this was the first purpose-built factory Strand Electric had. One of the purposes it well proclaimed was that it was to cost as little as possible. The building in Power Road was no architectural masterpiece and everywhere one was conscious that it had just enough substance to hold itself up. Nevertheless, this factory, probably the first built for stage-lighting in the world, has a warm place in the hearts of Strand men and its closure on Friday, 1st October, like the passing of an old friend, demands that we pause awhile and think.

From this small factory came forth virtually all the jobs whose names made Strand world famous. The mass-production side of things, beginning with the Patt. 23 in 1952, had to be hived off first to Vauxhall, then to Kennington and later to Gorton, but the real craftsmen remained at Gunnersbury—most of them for extremely long periods of service. With a school-leaving age of fourteen it was quite possible to have forty years or even more.

It was at Gunnersbury that all the big jobs were made—the tailor-mades requiring manufacturing skill and imagination. This last was both necessary and convenient because it allowed one to get away with just a simple assembly drawing and thus get a job launched and made quickly. In its heyday it was commonplace to see the same man—one of the fitters—cut up the iron, build the frame,

and from adapting what comes to hand. If everything comes to hand then what? However, hope on—even if the building and its content is dead right, you can be absolutely certain that not enough has been budgeted to staff and maintain things on the scale to which they were designed. Cash does not flow for ever: the place once opened, funds will dry up, and so too we better had!

assemble on it all the made-in and bought-in bits (clutches, dimmers, relays, motors, shafts and bearings) and then wire the lot—both the high-voltage busbar distribution and the low voltage action. Testing followed and re-assembly on the site—maybe just down the road at the White City or way up North or across the seas. Like as not the same man stayed with the job—or rather "his job"—the whole time, including "standby" in the opening week.

Things cannot be done this uneconomic way any more. Nor can a man have his own engine with his name painted on the cab as he used to in the earlier decades of the railways—his to cosset and grow fond of.

In industry times change and with them customs. All these small, crowded, ill-adapted Strand Electric factories have now been absorbed in one enormous factory—a veritable Versailles of green crystal and air conditioning—all in spacious surroundings in Kirkcaldy. Never in Strand's wildest dreams could they have imagined such a place.

The working conditions are now ideal, but the work itself . . . ? There's the rub, the better the equipment is designed to be made and the better the means and the machines provided for making it, the less fun it may be to do the job on the bench. Meantime let TABS pay a tribute to Gunnersbury and all (all?—well, nearly all!) those who worked there. Without the things they made, TABS itself would have had no purpose to serve.



Birmingham Repertory Theatre

Triptych

Frederick Bentham

People often ask me what theatres they should see. At one time the answer was very easy; we only had one new building—the Royal Festival Hall—and, while it was a rotten theatre, it was a very exciting auditorium when the place was seen as conceived—namely as a 3,000 seat concert hall—so a trot over the river was considered essential. Before long we had *The Mermaid* and *The Nottingham Playhouse* and . . . but somehow I was never very keen on sending people to Coventry—particularly once it involved seeing that back stage. Since that time the pace of theatre building has increased and now there are so many new ones that it is important to be selective. It is not just a question of which are those

theatres that are new, but which are those that carry a message or a lesson—or since they are theatres—some kind of thrill.

The three I am about to describe all warrant a visit, for although two are at first sight orthodox prosceniums they are so different in purpose. All three theatres have this in common—they are objects of Civic Pride and considerable trouble has been taken to make them architecturally important as buildings. Indeed up to now no completed theatre in this country has been given such an architecturally dominant site as the new Birmingham Rep. It is a pity that this prominence is mainly bestowed on circumnavigating motor cars puzzling their way through Birmingham's

traffic engineering. Thus the excited cry of "There it is—the theatre!" is likely to be followed by a despairing wail as one is sucked down some automotive sewer whose end, wherever it may be, is certainly not the theatre itself.

The new theatre looks large and impressive in much the same way that German theatres do. You cannot miss it even if it may be difficult to decant oneself there. Inside it still feels large and in a strange way this mood seems to fit Birmingham. Why strange? It is our second city after all. Perhaps they should have built themselves an Opera House. In many ways the scale of this building is such that it could almost be an Opera House. This is the evocation that I personally receive and this would be so whether one entered by the front door or by the workshop door. One of the two paint frames there is enormous—a reminder of Covent Garden. With all the talk of Edinburgh's Opera House one wonders how it will compare with this theatre.

Of course 900 seats would be small for an Opera House but as new theatres go today it is a large number. The proscenium theatres that we have seen in the pages of TABS have tended to hover at 550—the largest being Nottingham at 750. I know when I write these words that the Belgrade is an exception and seats 900. So it is with this last that we should compare the new Birmingham Rep. What happens is people remember the Thorndike Leatherhead, look around at Birmingham and think it's big. Well so it is; it has twice as many seats and like Leatherhead all on one floor.

There are twenty-one steeply-stepped rows of Rank Strand luxury, cinema-type seats which evoke in me the feel of the enormous circle at the old Empire Cinema, Leicester Square. In place of the wide screen there is the wide stage—a proscenium opening of fifty feet—well over twice that of the Old Rep. The critic in the Guardian refers to "an immense front curtain". A curtain is a device to conceal scene changes and hitherto 42 ft., as at Covent Garden or Drury Lane, has been wide enough to symbolise the ultimate in scenic extravagance as far as we in

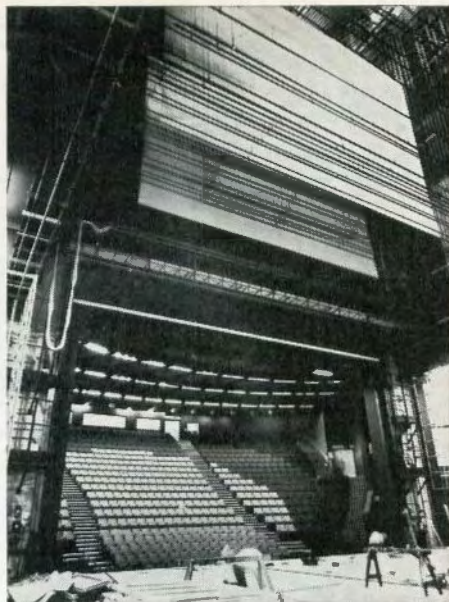

Backstage at the Birmingham Rep.

Britain are concerned. The opinions expressed in an article such as this must be purely personal so readers will not be surprised to find me once again proclaiming my dislike of wide openings as a solution to the problem of getting an audience reasonably close to the stage. It is a paper solution, because the audience are only close to the *part* of the stage nearest to them. Moreover the auditorium forms a wide fan of 100 ft. at the back, which of course means that the rows holding the most people are those further from the stage.

It is sometimes argued that a very wide opening is no longer a pros. Even if this were true, provision must be made to reduce the opening at times. The resulting structure, even when it takes as here the form of two mobile towers carrying both scenery and lighting equipment, tends to form a decided proscenium—a false pros. It is of course the style not size of the production on an end-stage which governs whether it feels "open" and in contact with the audience or not.

There are two inescapable components

- | | |
|----------------------|------------------------|
| 1. Stage | 9. Flys |
| 2. Understage | 10. Lighting galleries |
| 3. Orchestra pit | 11. Studio theatre |
| 4. Control room | 12. Entrance foyer |
| 5. Paintshop | 13. Lighting slots |
| 6. Scene dock | 14. Lighting bridges |
| 7. Grid | 15. Dressing rooms |
| 8. Loading galleries | |

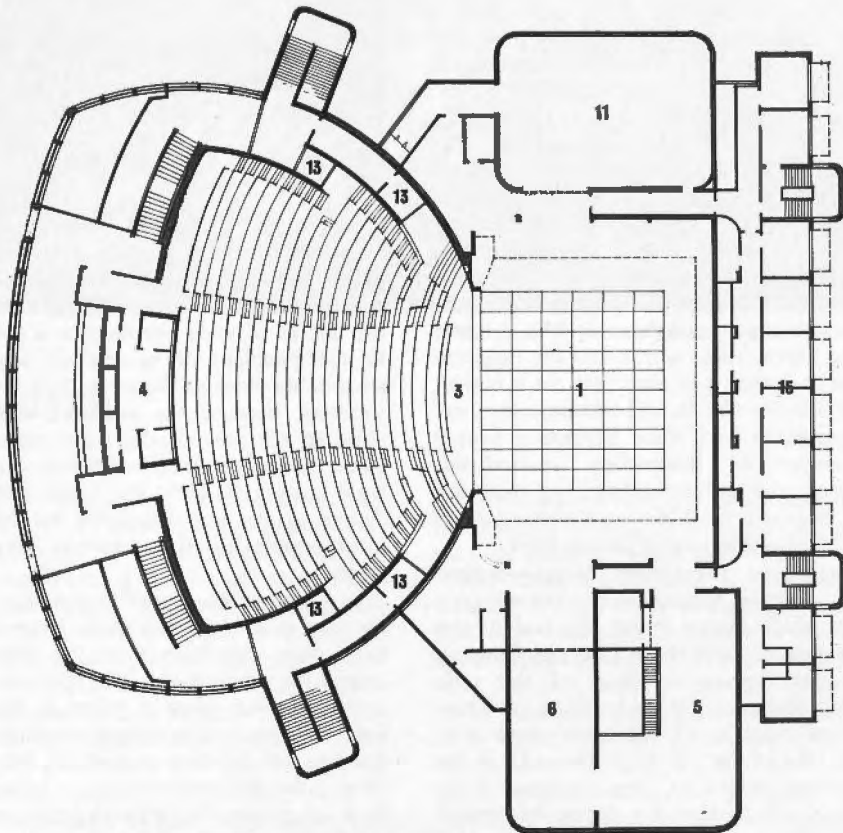
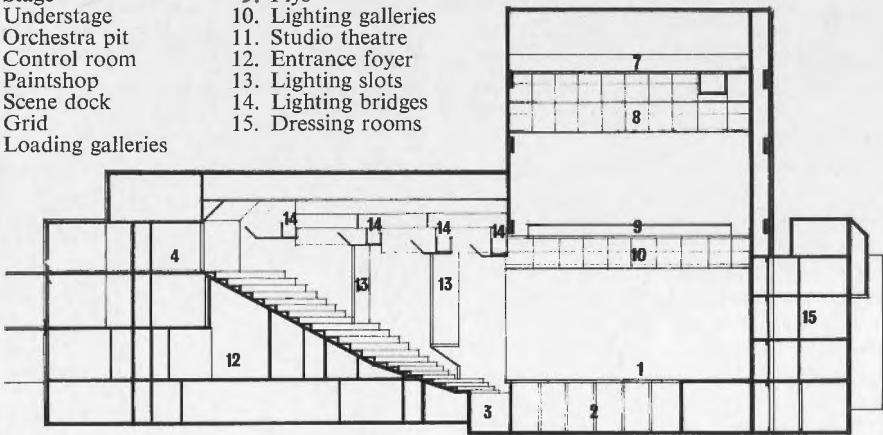

Feet 0 10 20 30 40 50 60 70 80 90 100

Birmingham Repertory Theatre. Architects: S. T. Walker & Partners, Graham Winteringham in association with Birmingham City Architect.

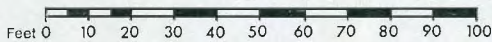
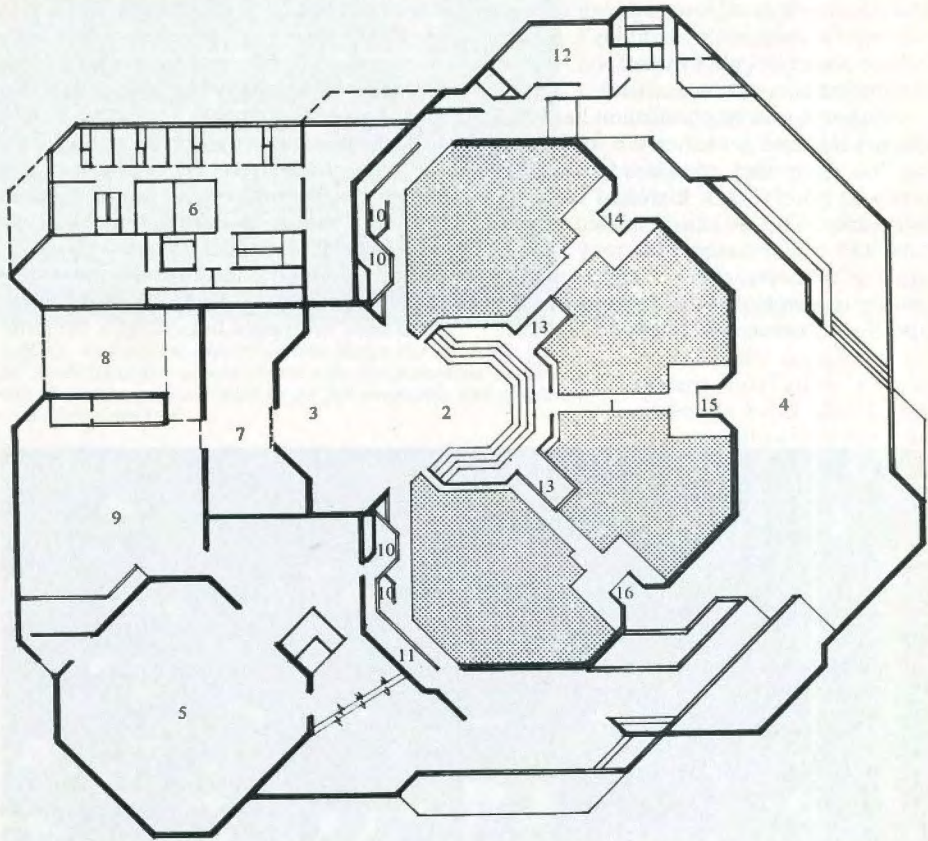
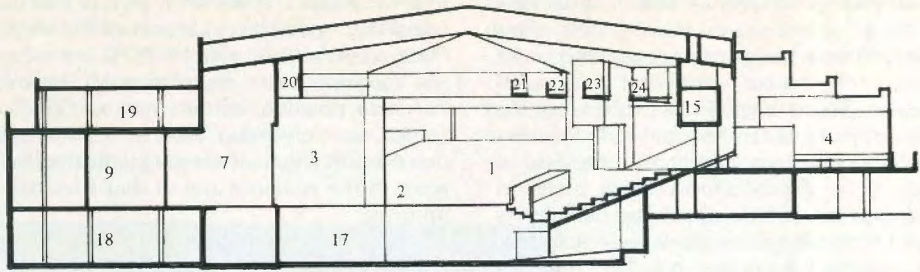

- | | | | |
|-------------------|-----------------------|-----------------------------|----------------|
| 1. Auditorium | 7. Backstage Assembly | 13. Vomitories | 19. Plant |
| 2. Stage | 8. Unloading | 14. Lighting control (over) | 20. Hoist Room |
| 3. Rearstage | 9. Carpenters shop | 15. Stage Manager (over) | 21. Bridge I |
| 4. Foyer | 10. Boxes | 16. Sound control (over) | 22. Bridge II |
| 5. Studio | 11. Wheelchairs | 17. Stage basement | 23. Bridge III |
| 6. Dressing rooms | 12. Toilet | 18. Scenery Store | 24. Bridge IV |

Sheffield Crucible Theatre. Architects: Renton Howard Wood Associates, Nicholas Thompson and Robin Benyon as Job Architect.

in all stage productions—first the smallness of the actor and second the largeness of his surroundings. All surroundings tend to be large in a theatre—even if it is a small theatre. The struggle lies in increasing the apparent size of the first and reducing that of the second except perhaps in the case of scenery for Grand Opera. Even there, in just one act of one opera the designer is faced with using the same stage to represent successively Amneris' boudoir and an "outside the temple" large enough to hold a Grand March in. With today's topless Desdemonas the scale of what you have to offer becomes even more critical.

Along with a large proscenium has to go a large stage and workshops to feed it and this has been well recognised. The Birmingham grid is 75 ft. high and the stage 56 ft. deep. To this can be added a forestage and this represents the only sign of niggling economy. In a theatre with a lighting control of the instant-memory type the absence of forestage/orchestra

lifts for a quick conversion in this area is somewhat odd. The main part of the stage floor, an area 46 ft. wide by 39 ft., is modular and removable so plenty of interest becomes possible in the form of levels, trucks and revolves. This is a looking-down-on-the-floor-of-the-stage theatre for most of the audience and of that I heartily approve.

One could scarcely conceive a greater contrast than that represented by the Crucible Theatre, Sheffield. The impression at Birmingham is everywhere of a large theatre both inside and out, whereas the Crucible feels small but not, one must hasten to add, cramped. The plans of both to the same scale on the previous pages show the true proportions. Of course it is the thrust form with just fourteen rows around it that is responsible for this. Here at Sheffield is the direct descendant of Stratford, Ontario or perhaps more correctly the Assembly Hall, Edinburgh. The 1010 seats in straight lines suggest the latter

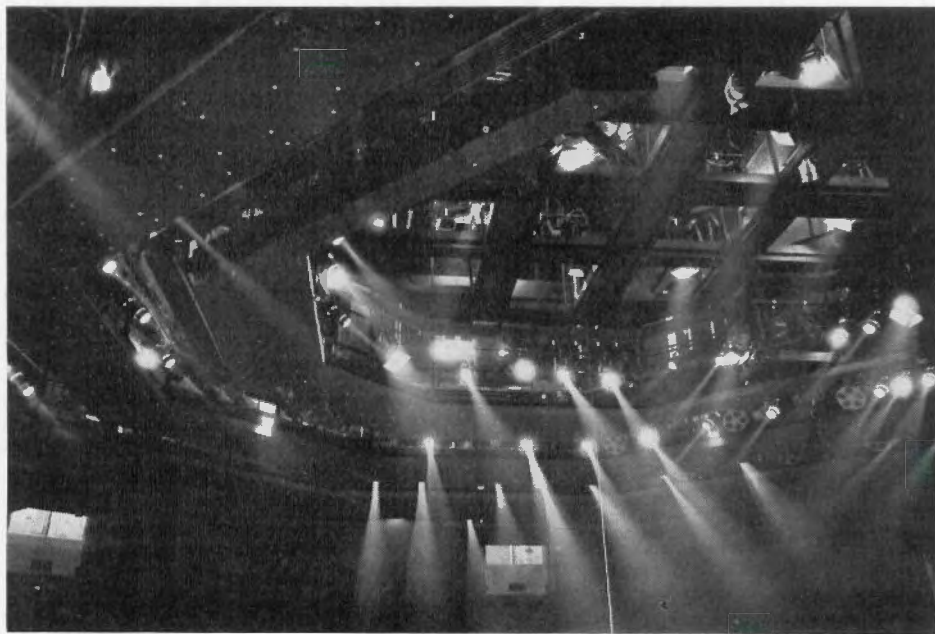

Lighting Bridges over thrust stage at the Crucible Theatre.

anyway though there are no balconies. The Sheffield form could, if necessary, have held half as much again with a balcony and would perhaps have felt even more compact as well. There can be no doubt, that Ontario shows with its 2,200 seats, that this is the form to bring actors to a large audience.



Sheffield Auditorium under working lights during rehearsal. The small balconies shown either side are somewhat remote from the stage and are said to be for orchestra and special production gimmicks.

The thrust form brings with it however the problem of that auditorium wall which inevitably forms the background to the stage. There have been various attempts to prevent this becoming too dominant and to provide, ever since the original permanent set at Ontario, some possibility of scene change. The Crucible allows considerable flexibility—even including a proper grid over the rear stage. Hinterbühne is a better term perhaps, since presumably it is more a preparation area for trucking and off-stage perspectives than an acting area. Heaven forbid that this area, whose downstage beam has already become known as the pros. beam, should become a proscenium stage. Yet the whole of the thrust stage itself is demountable.

It is obvious, however, that lessons have been learnt from the several, distinguished, thrust predecessors. All that ingenuity can provide, in the shape of structure and scenic flexibility within this form, is there at Sheffield. This theatre is just what we in

this country need further to explore the thrust form.

As is proper to the raised thrust idea, the stage is separated from the audience by a moat which also provides independent entrances for actors from the direction of the audience through covered ramps. (You all know what they are called but Sheffield doesn't like the term!) The seating is something of a visual problem, ragged edges to the blocks and even some single seats where the straight lines join on the angle, but curved lines form no part of this architectural concept.

The most remarkable part of both the new Birmingham Rep. and the Crucible is the technical installation, of which the stage lighting is not only the most important part but the one I used to understand. Quite honestly I feel out of my depth when I see the complexity of a modern installation. I yield to none my belief that I can still think control with the best of them; it is the other end I shrink from. Positions everywhere mean a large number of circuits (Birmingham 265, Sheffield 200). Since the Q-File Control in both cases has 140 dimmers* this means patching which I do not like, and in any case I regard numerical call-up as a form of control patching on top of that. However, this is a personal thing and the vast expert knowledge of lighting requirements today enshrined in Theatre Projects Consultants Ltd. is almost beyond challenge. Nevertheless, much as I look forward to seeing Richard Pilbrow handle the lighting at The Crucible for that most lightable of plays, *Peer Gynt*, I cannot help feeling that it may not have been accidental that the lighting positions at Stratford Ontario were so few and so impossible of access or addition. That wily apostle of white light, Tyrone Guthrie, may have very well realised what he was about. In all fairness one ought to conclude with the remark that the Vivien Beaumont

*Desk capacity 160.

theatre in Lincoln Centre, New York—a rather similar thrust format—reputedly has 800 circuits.

When a thorough examination is made of a technical subject, writing the specification becomes a little like sitting down to write a constitution or a binding legal

the lighting control desks in both theatres by the gratuitous addition of a large, flat, Formica desk surface which pushes the operator further away from his observation window. Some snappy work with a saw when no one is looking is my counsel. Just the centre part so that you can sit into the desk.



Colin George directing first rehearsal at the Crucible Theatre.

The three control rooms at Sheffield appear as part of three vertical features breaking into the last rows to left, centre and right—housing lighting, stage management and sound respectively. By any standard these are pokey and, while one does not at least have to pass through the audience, long and very narrow passages, seemingly moulded into the solid concrete as ventilation ducts or something of the sort, have to be negotiated. It would appear some people are to be permanently barred access to these priest holes. In contrast the

agreement. It is fascinating that the Theatre Projects book* takes 1,200 words to describe "The Working Lights" in the stage area at Birmingham. Most people would dismiss this in two or three lines as an uninteresting subject but it is in such detailing that a consultant shows his worth. Never judge a consultant by the grand plan—he is unlikely to have had much to do with that—but look at the detailing, the positioning of socket outlets, fixings, switches on a panel and the like. The egg crate frameworks for instance, to carry spots vertically over the stage at Sheffield, are models of ingenuity. Something which I cannot approve however is the enlargement of



Crucible thrust stage under stage lighting.

lighting bridges are a joy to walk upon—none of the more usual acrobatics being necessary, intrusions by ventilation trunking being kept to a minimum.

One would like to dwell on the public areas but, as TABS does not permit this often and in any case we have not seen them complete and lit up, it is better to

** The theatre consultants for all three theatres were "Theatre Projects Consultants Ltd." who publish the full technical data—as an A4 book for each theatre (available from them at £1 each). We are grateful to them for the use of their plans and photographs.*

hurry on to the third of our theatres.

The situation at Swindon is quite different. Both Peter Dews at Birmingham and Colin George at Sheffield had strong ideas as to what they wanted their existing repertory companies to move into. Also Swindon has a population of 100,000 compared with the million and half million respectively of the other two. The Wyvern theatre has to be the centre of the cultural activity of the town; there is no other. In consequence it houses the Arts Centre as well and forms the first section of the Civic Centre which is part of a plan to shift the town centre away from the famous railway workshop area. Those who like me only know Swindon from the railway line get a big surprise.

It would appear that this is no case of a reluctant local council being compelled to fork out for someone else's enthusiasms—quite the contrary—the driving force came from within the Council itself. The Wyvern

theatre assumes such a varied programme that it is literally multi-purpose but wisely not multi-form. If of the two theatres described earlier I seem to prefer the thrust stage, and I do, then equally I have no hesitation in saying that Swindon is right to go for a proscenium in this the latest version of the touring theatre. This term must not be misunderstood for there are workshops, and amateur shows at any rate will originate in the town. The stage has to provide facilities to make its visitors feel at home. It simply is not reasonable to expect one night or even weekly stands to have to cope with an out-of-the-way type of stage. Alwin Nikolais puts it well "What my company wants is a standard theatre." There are 652 seats and a proscenium 35 ft. wide by 20 ft. high—we have collected a number of theatres of round about this capacity.

The auditorium of the Wyvern provides its own solution to carrying this number of

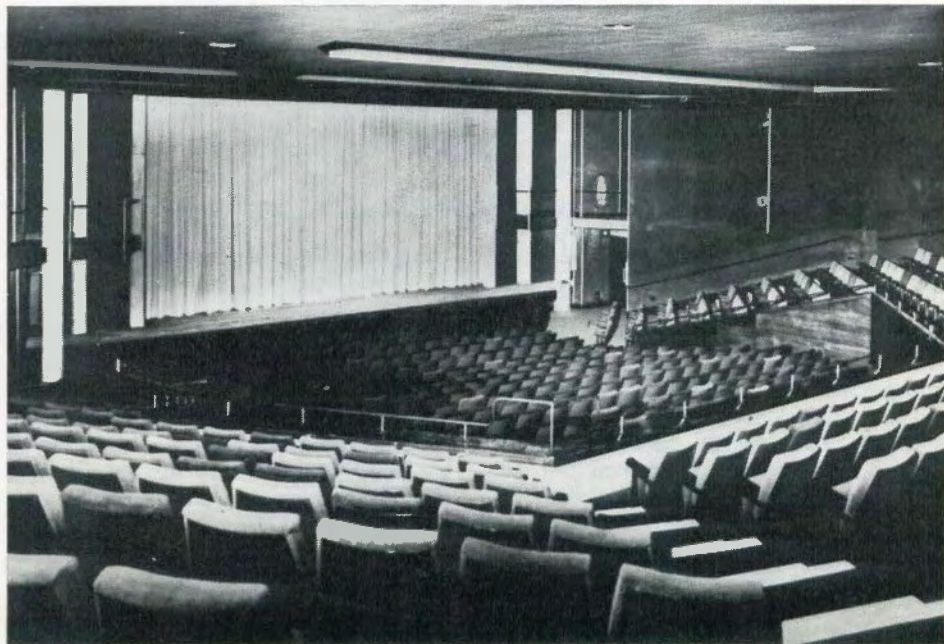

Wyvern Theatre, Swindon.

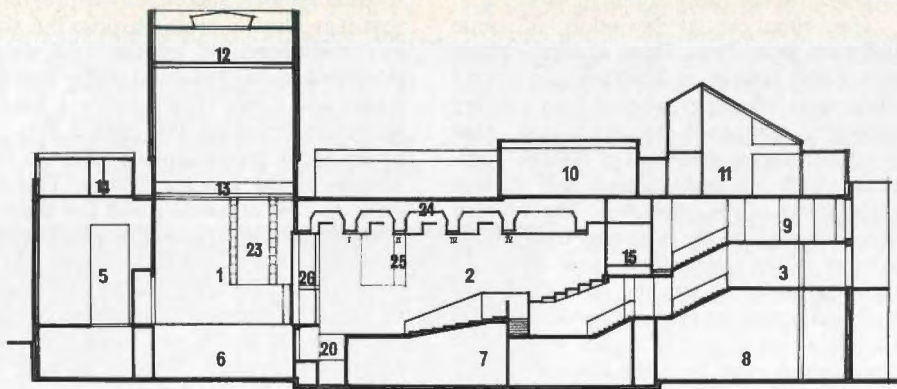

Feet 0 10 20 30 40 50 60 70 80 90 100

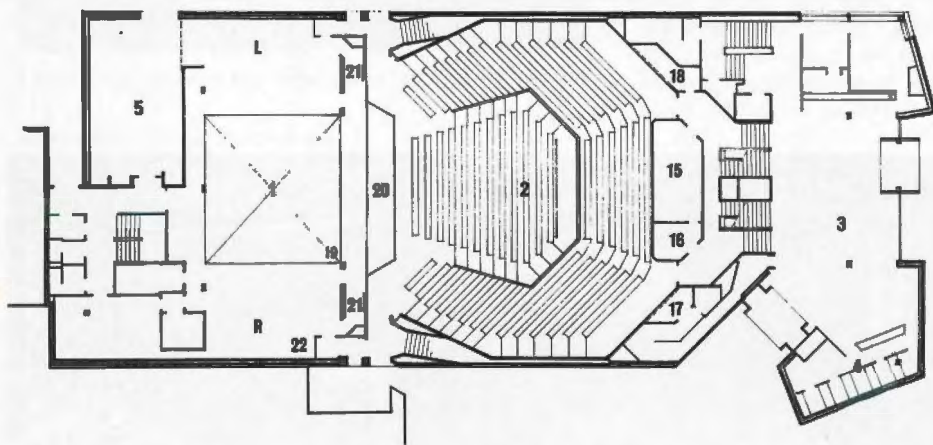

Wyvern Theatre, Swindon: Architects: Casson Conder and Partners.

- | | |
|---------------------------------------|-------------------------------------|
| 1. Stage | 14. Caretaker's flat |
| 2. Auditorium | 15. Lighting and projection control |
| 3. Foyer | 16. Joint control |
| 4. Cloakroom | 17. Box A (wheelchairs) |
| 5. Workshop | 18. Box B |
| 6. Understage | 19. Removable stage floor |
| 7. } Plant rooms | 20. Forestage lift |
| 8. } | 21. Assemblies |
| 9. Upper foyer | 22. Flying (working side) |
| 10. Rehearsal room/
Studio theatre | 23. Lighting ladders |
| 11. Art gallery | 24. Lighting bridges |
| 12. Grid | 25. Lighting slots |
| 13. Flys | 26. Juliet balcony |

seats on one floor. There is a centre group of about 200 seats surrounded by a terrace which rises from the same level as these at the stage end. This device, which used to be known as a stadium plan in the great cinema-building age, breaks up the lines of seating, allows separate entrance at the rear of the centre stalls, and yet does not condemn anyone to sit under a balcony. It also serves the useful purpose of confining a small audience—for a meeting shall we say—instead of allowing them to spread all over the place. The provision of an orchestra lift also helps multi-purpose use since the set for the week's show could remain on the stage, concealed by the house tabs or fire curtain—while such a forestage, with or without the lift gives an ample area for platform activities.

Another obvious use is as a British Film Institute cinema and care has been taken to ensure that the screen, which hangs just upstage of the house tabs when out of use, causes minimum obstruction. This is done in a most ingenious way by ensuring that the bottom part of the screen frame carries a line of lighting—the No. 1 spot bar no less. Thus when the screen is flown away it forms the pros. border or header. This downstage position is a good one anyway since it means least interference with anything set up on the stage.

There are the usual forestage entrances under Juliet balconies with their associated lighting slots and it goes without saying that these consultants (Theatre Projects again) have provided plenty of good lighting positions elsewhere.

In addition the architect's design of the proscenium provides an unusual arrangement of two fixed columns and removable panels on the sides of the stage which allow the Juliet Balconies and forestage doors to be put right onto the stage and to face the audience instead of sidling up on them. Opening up these panels presumably also gives a larger feel and acoustic for concerts. Of course there may be some who will regard the fixed column each side as an obstruction but I feel that the 35 ft. between them is large enough, and exercises a valuable discipline. The columns are part of the design by Neville Conder to

provide an architectural reduction of the opening, further temporary columns being envisaged for the amateur productions. Like the Crucible and Birmingham Rep. the Wyvern has a studio theatre for small scale and experimental work but in this case the studio doubles as a rehearsal room.

In view of the recent Manifesto on "The Human Specification in Architecture"* by Conrad Jameson it is interesting to examine the three buildings in that light. In each case the buildings are very much architects' buildings. The architectural concept rules the terms in which the requirements would be fulfilled. It is curious that the architect at Birmingham has a thing about curves whereas at Sheffield the rule is straight lines. Consider what might have happened if the briefs had been reversed. Swindon is by a straight line architect as well.

In 1963 Peter Moro interestingly combined both a circular plan for the auditorium and straight lines for the stage and front-of-house in the Nottingham Playhouse, though later at Hull he too went for straight lines which seemed to work out very well. If we think back to Nottingham however and decide for aesthetic reasons a cylindrical stage tower would be better, with a square auditorium, the design comes completely unstuck of course. A circle for an auditorium has the desirable effect of removing any corners remote from the stage where one might be tempted to make up the seat numbers. Seating seems to take up curved lines nicely. It certainly avoids awkward gangway untidinesses and as in Birmingham, where the gangways descend a very steep rake, curving lessens any tendency towards vertigo. Curiously enough when one comes to a stage curves are very unhappy. It is difficult to orientate to a curved area. This is one explanation why so few theatres-in-the-round have a circular stage. No sooner has one written this down than one realises that one of the commonest forms of stage throughout the world and the only one whose dimensions are standard—the circus ring—emphatically contradicts the notion. Fortunately one can

**The Architects Journal* Oct. 27, 1971.

go on to say that the two entrances on opposite sides of the ring immediately provide a decided axis. Reconciling a straight line stage to curved seating rows is thought by some to be difficult. Yet in Stratford, Ontario, to quote but one example, there is no problem.

These remarks are provoked by the notion of how far, in the face of the architectural concept, a client can possibly exercise any real influence over his building. If due to fashion the nearest an architect is prepared to concede to the circle is to lop off the corners of a square and make an octagon. Or if at another time, as with the BBC Television Centre, square studios have to be crammed into a circular format then all the consultancy and technical expertise in the world cannot satisfactorily solve the design of technical equipment to fit the left-over wedges.

It is part of Conrad Jameson's thesis that the users in the specific cases he instances—the students at Keele University—are liable to be completely misleading when market researched, even with the completed building standing there before or around them. If this is so then it would seem to be absolutely impossible to find out what they want when drawing up the brief.

With a theatre the question even arises who is the user? We know in these three theatres under examination who the client is, but who is the user? Is it the audience or is it the people putting on the show? Since the success of the enterprise will depend on both these users liking the building, it is a sad fact that their desires

may be diametrically opposed—that all too often the people putting on the show are only concerned with putting on the show.

The intriguing thing is the audience end but I know of little market research on what they like—inside the auditorium or outside it. For example, do they prefer continental seating in long rows or a number of intersecting gangways? In the front of house—to come back to the Keele case—do they want wide open spaces or small confined spaces? Should there be a few large bars or a lot of small ones? Are they happier in high rooms or low ones? Do they like to look out when in and do they mind being looked at when in—in other words, mind being made into an exhibition for the city in a crystal box, as is the case in some German theatres?

Is the theatre a meeting place or is it something you go to quite privately? Do you want your acquaintances to see who you are with? Do you want a bright light or cosy little puddles? What does concrete make you think of?

It is said the audience should be crowded together and aware of each other but who says so and on what is the opinion based? Are the massed bands of those spotlights as exciting a part of the theatre for them as for ourselves? How near to the actors do they like to be? Do they want to sit in the "side" seats which the thrust form so plentifully supplies? What really ranks as the best seat—but there we move out of speculation into certainty.

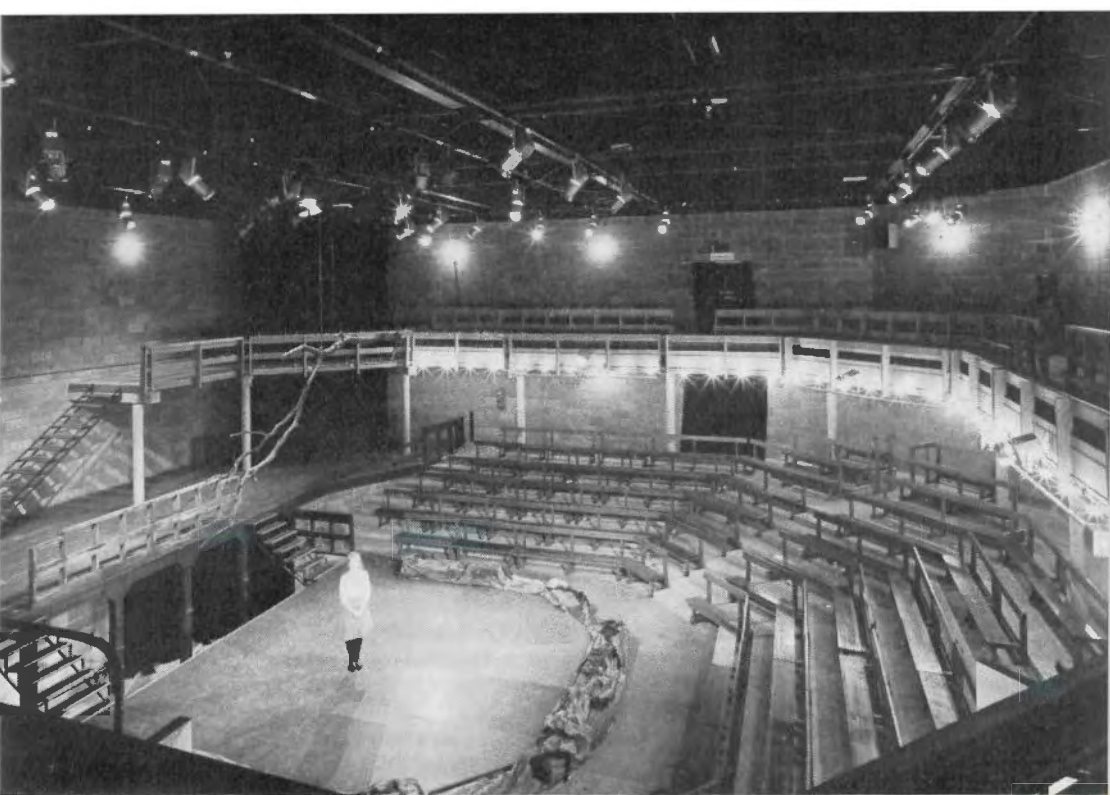

Young Vic Theatre. Lighting grid, access only from below by Tallescope. Thrust stage in low position.

Cutting your Shape to Suit your Show

People in glass houses shouldn't throw stones and, as a corollary, those wishing to throw stones—or ideas—about should look for an appropriate place to do it. Such a place in Frank Dunlop's eyes was an "instant warehouse", constructed in the absence of the real thing, as a home for the experimental, the unpretentious and the entertaining to knock about in until something gelled.

There seem to be two kinds of theatre built today. The first is a building erected by a committee—often a civic authority—to embody the abstract ideals of a society. The argument runs something like this. We

believe in aesthetics; drama is an art form; therefore we will build a theatre. Now in an earlier century this would have been a cathedral—not because one was needed to worship God or to further religion but because it befitted a town to have such a thing. Both these "temples" pose two questions: what happens therein and who goes there to see it?

The other sort of theatre is the servant to a single driving spirit. It is now over twelve months since the Young Vic Theatre opened in the Cut with aims not altogether dissimilar from those of a highly religious Emma Cons in the Old Victoria

Barbara Berrington

Hall just up the road—to reach across the social barriers now existing in Shaftesbury Avenue to the young people of the Cut. Nevertheless Bill Howell, the architect, has made it abundantly clear that in *his* brief there were only two things of importance—money and Dunlop.

Now one would think that some of the money from the temples would be diverted to the “missionaries” of theatre so that when the monument has been erected it could at least be bent to the artist’s will; or conversely—a much “leadered” thought—so that the artist will not build in solid concrete such quirks of his character as will last beyond his own time there.

To trust to so happy an outcome is to confuse aesthetics and ascetics. It is also to begin at the end and work back to the beginning. At the Edinburgh Festival for Dunlop’s *Comedy of Errors* the auditorium was determined by the dimensions of the tent he had pitched inside an ice rink. The stage was that space needed by the actors and the gaps they left untouched contained the audience—on condition there were 500 of them. The atmosphere was more that of a circus than of a play or perhaps was a subtle fusion of the two into something rich and strange. At any rate the critics liked it.

In view of this way of going about things, it is curious that the auditorium of the Young Vic was allowed so much architectural character—the “T”-shaped stage thrusting a long tongue into the audience—an audience of 400 sitting on rigid benches and confronting each other from side to side across a mere 27 feet or so—the emphasis of the surrounding balcony with its hard, defined pillars and abrupt gap just above the stage. This is not intimate theatre in the cosy way that one associates with that word, but something is almost bound to happen there. As Peter James, Dunlop’s assistant, explained, it is impossible for the actor not to be aware of the audience. The building thrusts him into this relationship. You can’t avoid it and you can’t avoid the reactions that come back either. They give the actor a new sense of his responsibility to his audience. Once you have a strong actor/audience

relationship the rest will follow. The relationship of both to the building is inevitable. Dunlop believes that the strong features of the auditorium are the things to which the actor relates, but for Peter James, also directing there, they are in many ways restrictive. To him this building is something to be explored and used and then cast off. He would prefer the box which can be all things to all men—the ultimate in flexibility—not too large or too finite and of infinite variety. Around this box would run a corridor permitting entrance at any level and at any point. Flexible seating units—light and easily moved around—would house the audience in a new position each night and the entire floor would consist of traps or modules so that on the instant caverns could yawn below*.

The all-over grid of the Young Vic is to Peter James too sparsely populated. Its fifty or so lanterns—though they seem adequate for all practical purposes—are merely scratching at the surface and in an ideal theatre the fields of light and sound would be the places where the money was spent. Vast sums of money exist for theatre—much of it being misused. It should be spent not just as capital but as production costs, to “push back the frontiers of experience”. In fact there is a sense that if you push back hard enough in all directions you must find something of value. And with all this he conveyed a kind of practical energy which stopped it from sounding a mere collection of high-flown phrases. The “Freehold”, he instanced, had worked marvels by concentrating on physical prowess—on making their bodies do and say what they please, but this was only one aspect of theatre. Why not, he demanded, a show without actors?

The audience that he aims to please is varied. Coaches of kids, students, people from the Cut and an estimated ten per cent of theatre fanatics mill about together. The priorities of this audience are as yet not fully known; its composition is in fact being

*We have a description of what is said to be just such a modular theatre which is now opening in California. We intend to publish this early next year as soon as we have photographs.—ED.

currently investigated, but it is obviously quite different—less predictable perhaps—from that at his previous home in the Liverpool Everyman.

Clearly the hard benches do not matter (the shows are not over-long—an hour has not been unknown) and most of the audience seem prepared to wait in queues, with only a modicum of grumbling, for both coffee and toilets in the interval. What does matter to these people and therefore what the Young Vic believes it needs, is, say, continental food or the ability to stay late talking over coffee or a drink—perhaps too the freedom they have to turn the coffee bar into a local club. Acceptance of these values by such a management is essential. Just the sight of the juke box can make the kids faces soften and their eyes light up as suspicion slowly gives way to glee. The gaudy doorway, the tiny foyer (auditorium right, coffee left, toilets straight on)—are eye-catching and unassuming. The company is aware that it is an intruder in the Cut. It is thrust into that society, into a real street where people work and live, and is a trifle incongruous. Just as the actors “thrust” on the stage must be aware of the reactions that come back so the whole theatre is sensitized by the hostility and friendliness that come from its locale. Only in its price (40p a seat) is it making real concessions to that public though many of its items are blatant popular theatre—catching attention by any and every means, and steering away as much as possible from “the academic” on the one hand and from “plush and velvet” on the other.

I am not trying to imply that the Young Vic has universal appeal. One member of the audience in his twenties found it had its own pretensions:

“It has this smell that says, ‘You are here for the drama; you are devoted to the drama—so you sit on benches and have a funny-shaped coffee bar.’ Perhaps it’s something to do with its being a thrust stage.”

If that is how you feel about this sort of place then stay away. This theatre is not for you. The Young Vic speaks out against temples not as such but because they use up

on trimmings or irrelevancies the money that could have built three simpler, cheaper theatres in a vicinity, each with its individual appeal—each doing just one of the things that theatre does well.

Just what these things are may, they feel, emerge in the next twenty years. Since the days of Shakespeare theatre has been lost to the ordinary man and become a luxury commodity with seats at £2.50 a go. It is



Wilson Bros. Butcher—business not as usual.

now fighting to combat not the material but the sureness of touch in the other two communication media. Films have recently realised themselves as a director’s media. Television is the medium for current affairs, for quickly and widely disseminating information and reactions. Theatre can be seen as fulfilling to some extent the role of a magazine—one which provokes—which comments, at leisure and in depth, on what the “dailies” or “the tele” raised over the past weeks or years.

Dunlop tries to make his work energetic and wholehearted and his *Scapino* is a

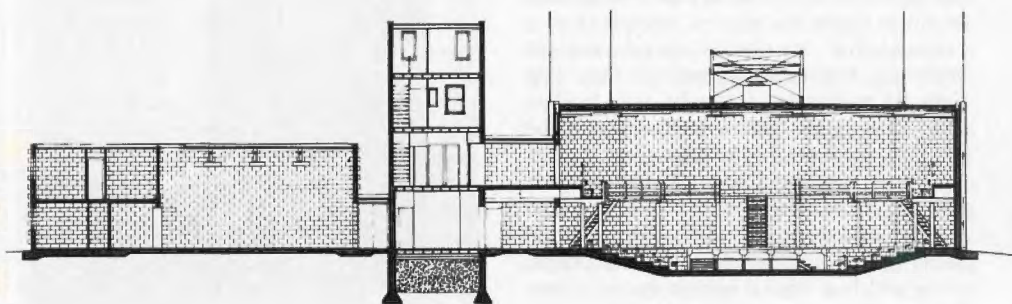
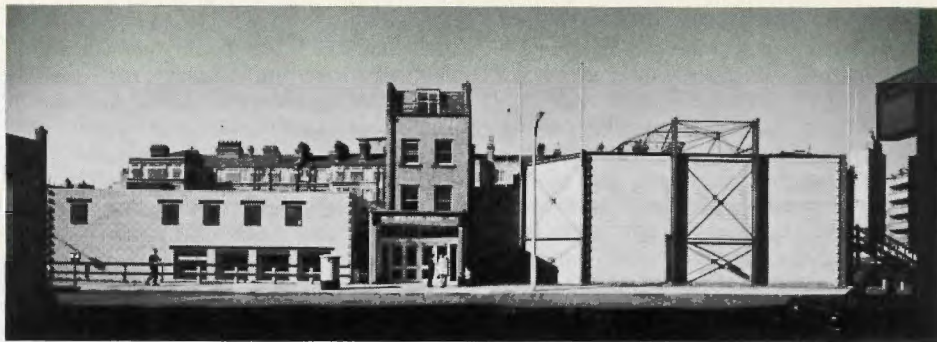

Feet 0 10 20 30 40 50 60

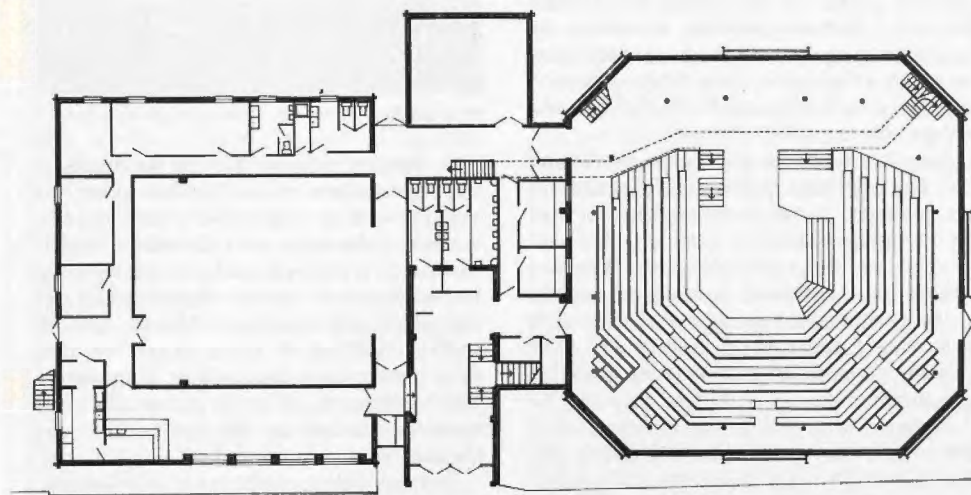

romp and a riot that physically sweeps across the entire house, using the space and the building in every conceivable way. Other productions take what they need more quietly. The theatre's architecture may or may not become part of the "set". Something like *Little Malcolm and his struggle against the Eunuchs* (the sort of title to deter even an enthusiast)—blocks off the lateral part of the stage with the "wall" of a room and seemed in many ways a box-set production done on a thrust stage while a visiting *Iphigenia* seemed to keep the thrust part of the stage as the multiple heroine's ambience while the outer world and its forces were relegated to the upper reaches of the balcony and lateral stage.

It is possible to alter the form of the stage in large measure with rostrums and curtains—even to the point where it can be hard to pass from one side of the stage to the other without being seen—but no effort so far has been made to change the position of the seating itself by say filling in the centre with seats. The shape of the site and the single entrance to the auditorium pose problems here and also dictate the position of the almost adequate lighting and stage manager's control boxes on the left. The view is reasonable enough but there is a constant danger of noticeable sound and light spill into the auditorium so the windows are covered by woven matting for most of the time.

There are all the other normal facilities backstage, though strict budgeting is very evident. The dressing rooms may lack washbasins (and originally had neither mirrors nor lights) but they do have windows and there is a shower and toilets

further up the corridor. One of the dressing rooms has been appropriated for a wardrobe—the original scheme for sharing this facility with the National at the Old Vic presumably having proved impractical—and laundering is done at the Coin-Op across the road.

A small scene dock juts out at the back with even smaller doors. The Get in to the stage is separate and generally considered adequate. Above the foyer (which is actually a converted butcher's shop economically incorporated into the new building) a small "tower block" (once the butcher's home) provides general purpose offices.

Behind the coffee bar lies a large rehearsal room. As with larger theatres enthusiasts now plan to turn this into a tiny 110-seat studio theatre. The walls are being soundproofed so that activities will be independent of both the larger theatre and the coffee bar and rehearsals for the first show are already under way. By the time this goes to press the youngest of all the Vics will have staged its first performance—and it is typical of this theatre that any available money should be spent in such a cause and not on coats of paint for the concrete blocks or on screeds and floor finishes, which might keep down the dust.

To this company Theatre is a glorious adventure from start to finish. Peter James could even talk, sitting in the butcher's attic, of a scheme drawn up by a designer he knows for a flexible foyer where, by angling screens and moving flats, the mood and feel of the building could change with every play—new colours, new relationships and all at funfair prices—"Only think," he said dreamily, "of all the fun you could have just buying sweets."

◀
*Young Vic Theatre. Architects: HKPA
Howell, Killick, Partridge & Amis.*

Entrance via old butcher's shop centre; on the left rehearsal room doubling as studio theatre with coffee bar in front and dressing rooms around the sides. On the right main theatre showing thrust stage built up to high level; passage to cross under rear stage shown dotted.

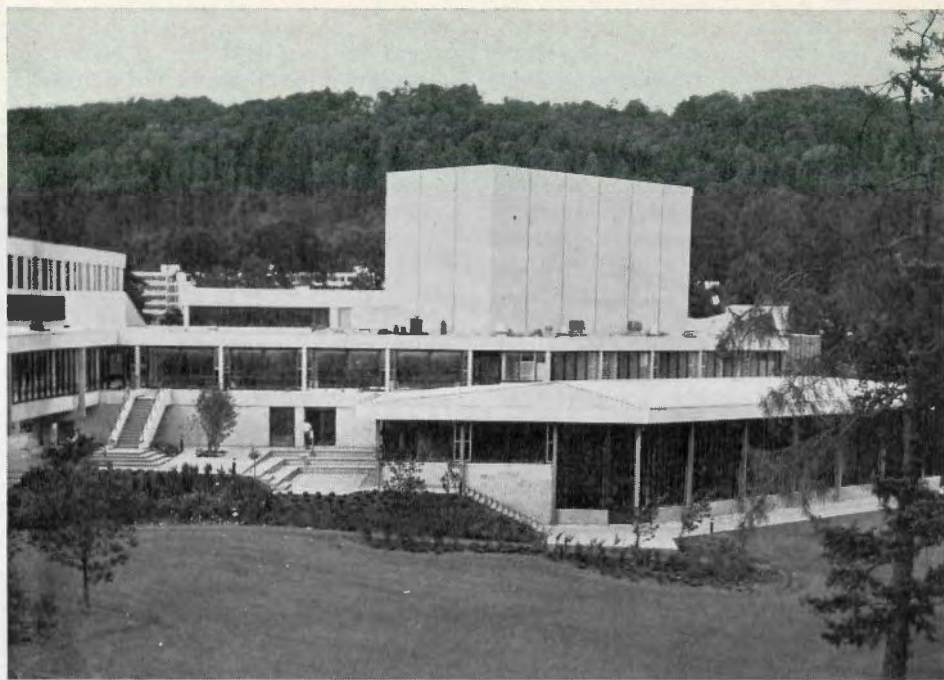

MacRobert Theatre, Stirling University. Exterior, showing restaurant (bottom right), recital room (next to restaurant centre right), fly tower. Main entrance is out of shot extreme left.

MacRobert and Brunton

Francis Reid

In Stirling they have built a theatre which I can get really enthusiastic about. This is my kind of theatre. This is a theatre which would give me audience pleasure if I sat in front, technical pleasure if I worked behind, and it has announced a programme composed entirely of my kind of show.

A subjective judgement perhaps, but theatre is a subjective place and anyone who is looking for an objective analysis of critical scenic paths or a reasoned criticism of the working-light switchboard should read no further. As far as I am concerned, it is with this building that *Theatre Consultancy* comes of age and justifies itself as a profession. For not only does this building avoid the technical pitfalls, it also avoids the technical excesses.

The MacRobert starts with tremendous natural advantages in its site. I would not insult the grandeur of this "University of the Hills" by attempting to describe it by means of such an inferior communication medium as Eng. Lit. Let me just say that the location is totally theatrical and that the architect has had the good sense to let his buildings be totally dominated by it and to concentrate on providing an environmental awareness of loch and hills for those who labour within the campus; and even the most megalomaniac theatre man must be cut down just a little by these hills and their Wallace monument floating in expertly cued dry-ice.

Stirling University is perhaps fortunate in having no department of drama; theatre is therefore free to serve its true master—the audience. And theatre in Stirling will

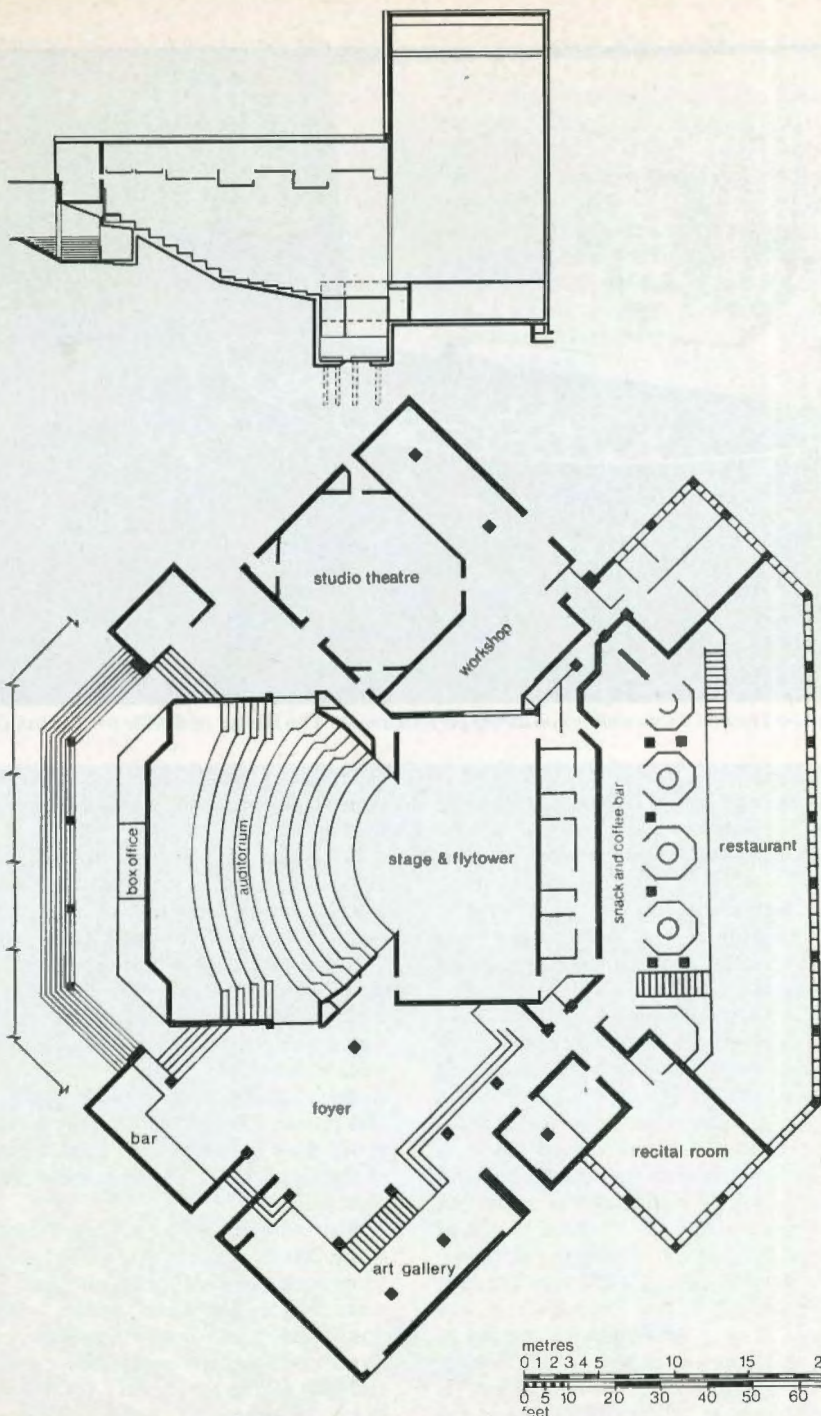

MacRobert Theatre, Stirling University. Architects: Robert Matthew, Johnson-Marshall & Partners.



MacRobert Theatre. Main auditorium during performance of The Barber of Seville by Scottish Opera.

not be restricted to the drama; that this is a dramatic *and* lyrical theatre is evidenced by the appearance of *Scottish Opera*, *Prospect Productions* and *Scottish Theatre Ballet* all within its opening month. And the programmes for the last quarter of 1971 include examples of practically every possible form of visual, musical, theatrical and cinematic art.

How will the building cope with all this? Is there a vast stage with complex machinery and a memory switchboard controlling a multi-saturation lighting rig? No. Just a goodly-sized proscenium-framed flat space with an ingenious twin-wedged pit/fore-stage. Twin auditorium lighting bridges and side slots give the right lighting angles yet the lanterns can be focused without acrobatics by this sixteen-stone electrician.

Lighting control is by a 100-way Threeset doing exactly the job for which it was designed. And as we now have a right to expect, this control, as well as the flexible sound and film-projection equipment, is housed in a suite of control rooms at the rear of the auditorium. (And also as we

expect—but not of right!—the ventilation system performs at a steady mezzoforte throughout.)

Wing space on the prompt side is perhaps rather restricted but is nevertheless generous in comparison with that of many touring theatres we have all known and on the OP it opens onto a goodly-spaced dock/workshop with paint frame. The dock-doors are a bit restricted because of an external walkway passing right round the theatre, but it was pleasing to note that the theatre technical staff seemed to think it quite right and proper to sacrifice a couple of feet of get-in door in favour of a panoramic view of the Ochil Hills. They get their priorities right in Stirling.

Also with access to the workshop area is the 200-seat studio—just a flat rehearsal room with portable (or should I say transportable) seating units and a correctly-positioned, all-round lighting gallery. Dressing rooms, of course, have windows, and Wow! the view. And for those who share my horror of the hanging blockage of the cinema screen in places like

Billingham, let me recommend this slim screen hanging in the obvious position—where the Number One spot bar can be brailled underneath it.

The main auditorium has 497 seats in a single-tiered sweep of 15 rows and is in the fashionable, dark-walled, severe style with intense downlighters on the seats. As a good lighting man should, I have always advocated this style but am now frankly beginning to have second thoughts, for as I get older I am increasingly willing to put up with some stage lighting scatter if the auditorium will let me enjoy those anticipatory magic moments when we await as an audience the rise of the curtain.

But on the whole, this building works for me because it is in *scale*. There are no costly excesses in one department at the expense of another. It is perhaps significant that its Theatre Consultant (John Wyckham) was for many years a Production Manager responsible for achieving maximum artistic success while keeping one eye on the clock and the other on the budget.

This is a theatre with a true purpose and it is truly purpose built.

On the other hand, I am not quite sure of the purpose of the Brunton Theatre in Musselburgh. It has two features in common with the MacRobert; they were both built largely as a result of bequests (hence their names) and they are both built to those high technical standards which show how far we have come in the past ten years or so—the Consultant in this case being Martin Carr.

The Musselburgh theatre is a very ingenious building: the stage uses its corner siting to produce wing-space in an imaginative way which augurs well for the Edinburgh Opera House, soon to come from the same drawing board. It is a nicely-scaled, imaginative, workable building, but (and I'm afraid it's a large *but*) it just screams out for a resident company to develop its potential. But Musselburgh has a population of about 18,000 and is only six miles from Edinburgh; our theatrical awareness is developing fast—but not that fast!

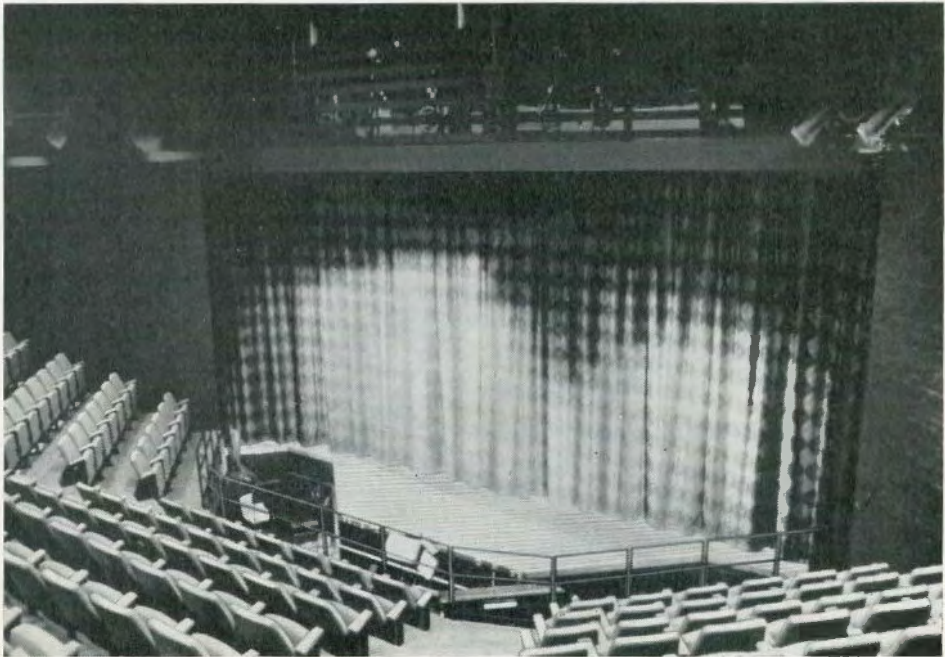

Brunton Theatre, Musselburgh.

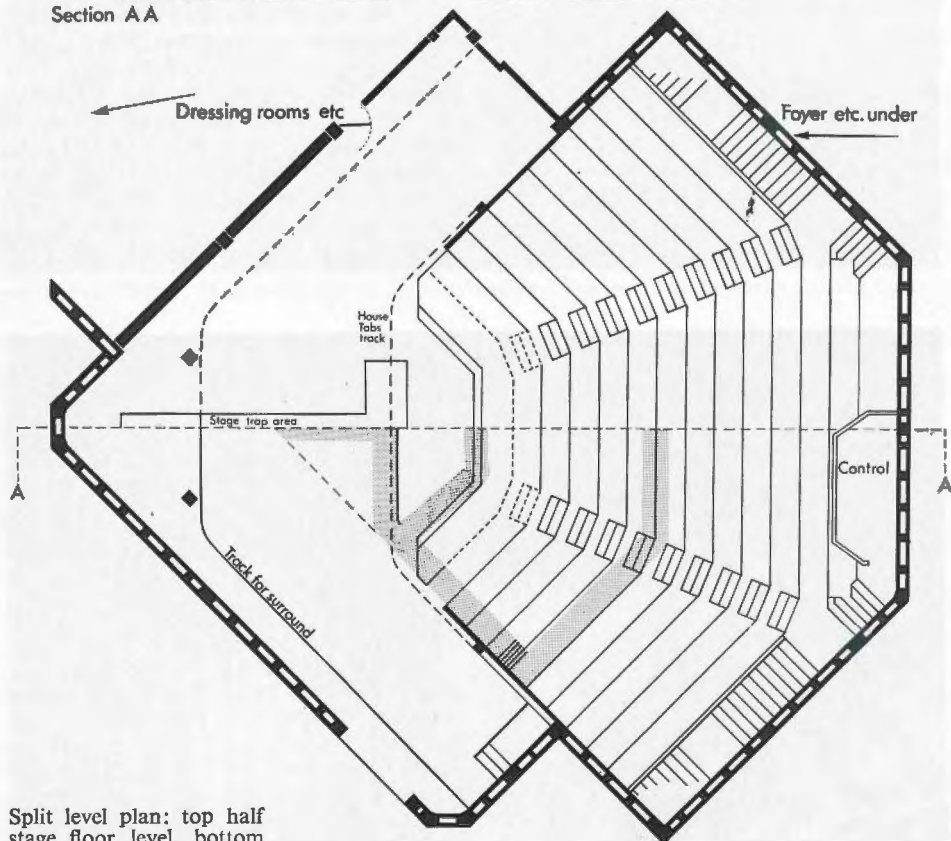
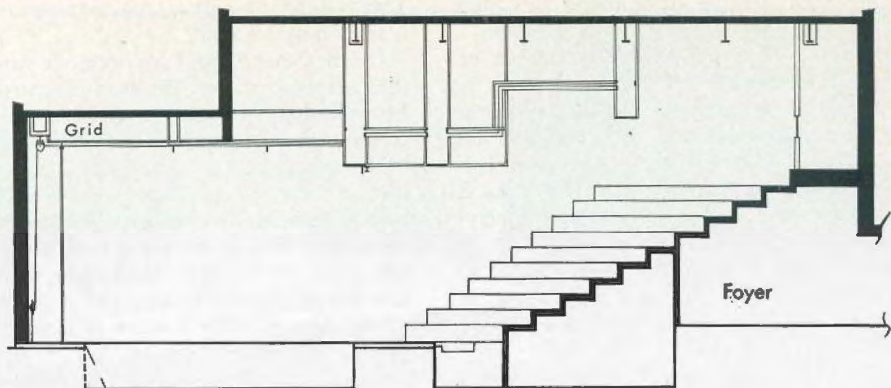

Split level plan: top half stage floor level, bottom shows overhead detail and lighting bridges shaded.

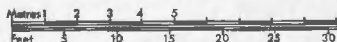

Brunton Theatre, Musselburgh. Architects: Rowand Anderson, Kininmonth and Paul.

The theatrical diet in Musselburgh must therefore be small visiting companies and local amateur societies: not the ideal role for an unconventional but imaginative theatre without flies, although one hopes—even if one doubts—that the local Gilbert and Sullivan supporters will feel freed from the tyranny of backcloths and wings. Anyone who succeeds in erecting backcloth and wings on this stage will I suspect find himself defeated by sightlines.

However the local authority has placed the direction of the theatre in the hands of Kenneth Lowe, a man who has created successful policies in a string of such

unlikely places as the Sophia Gardens in Cardiff; it will be interesting to watch his formula for making the Brunton into a viable project.

When I returned from National Service in 1954 to my home in Musselburgh and set about planning a career in the Theatre, it never occurred to me to consider working in Scotland; there was virtually no Scottish Theatre to work in. It is marvellous to find, less than twenty years later, such a healthy, vigorous, developing Scottish Theatre of which the MacRobert and Brunton are just two examples of the tip of an exciting, imaginative and technically-sound iceberg.

Stage Lighting Circuits

Schedule of lighting arrangements at the theatres described in the three preceding articles.

Young Vic

Direct circuits	30
Control SP 40 (Presets 2. Groups 2)	
Dimmers	40 × 2 kW
Patching	25 to 10

Musselburgh, Brunton Hall

Outer FOH	14
Inner FOH and No. 1 spotbar	14
Control SP 40 (Presets 2. Groups 2)	
Dimmers	40 × 2 kW
Patching	12 to 29

Stirling, MacRobert Theatre

FOH	25
Flys	55
Stage Dips	20
Control Threeset 100 (Presets 3. Groups 9)	
Dimmers	8 × 5 kW
	92 × 2 kW

Swindon, Wyvern Theatre

FOH	44
Flys	49
Stage Dips	20
Control Threeset 100 (Presets 3. Groups 9)	
Dimmers	76 × 2 kW
	4 × 5 kW
Patching	15 to 40

Sheffield, Crucible Theatre

Flys	170
Stage Dips	30
Control Q-File 160	
Memories 100	
Dimmers	120 × 2.5 kW
	20 × 5 kW
Patching	30 to 100

Birmingham, Repertory Theatre

FOH	86
Flys	158
Stage Dips	25
Control Q-File 160	
Memories 100	
Dimmers	120 × 2.5 kW
	20 × 5 kW
Patching	50 to 150

Slight on stage lighting

The scene is set in the drawing room of an ordered establishment in London's West End. The room, which is small and not particularly well furnished, can be entered by a door U.S.R. To the right of it and somewhat downstage stands an upright chair, above which is suspended a two-armed wall bracket of the kind now found only in JMB Hire. To the left of the door stands a telephone table which is surmounted by a crude sketch of Winston Churchill executed in pen and ink and lacking the essential cigar. Beyond the table is a high window with a few fronds of greenery just visible through the skimpy folds of net curtain and a little downstage of this stands the outline of another upright chair with its attendant wall light. The only concession to true comfort is an armless settee which occupies the centre of the room and behind which a table holding a couple of bottles can vaguely be discerned.

Scarcely any of these details are in fact visible when the curtain rises since the sole illumination is a broad shaft of moonlight through the window from the garden beyond. The room is quite unoccupied, but the PS loudspeaker nevertheless bursts into energetic life.

REID. Well, this is starting to build the picture. Now let's assume that the cues start in the way that they always do—usually not with the first act of the show but with the second act. It's moonlight, and the curtain goes up and the moonlight is streaming through the window. My favourite moonlight is without a doubt No. 61 (slate blue). I have to put my cards on the table and explain I'm a romantic, and that the moon to me, no matter what Fred Bentham may say, is blue—it's very blue—but the sort of moon I want is one that's normally blue, rather cool perhaps but when it strikes an actor's face I want it to be warm and this 61 of course is marvellous for this. Unfortunately, when you photograph it, it comes out slightly purple.

BENTHAM. Yes, it's quite extraordinary. I'll have to admit it's a good colour as you see it on the stage. In fact, I almost thought of copying it for some of my more exotic colour music but haven't yet—unless it's

been left in the lantern by accident. Of course the real thing to say about moonlight is that it is a very low level of lighting, at which we do not see colour at all, and there's no filter that we or anybody else makes which enables one to cut out all colour and just get that extraordinary black and white.

The other thing I love saying about moonlight is the fact that on the stage we're always using much higher levels of light than in real moonlight and for sunlight we're using much lower levels than for sunlight. In fact sunlight and moonlight are often at very nearly the same intensity on some stages. There's certainly not much difference between them, so you've got to rely on colour to establish, perhaps, that it is moon.

Enter Lyn through the door U.S.R. She is an attractive and energetic Australian and moves immediately to the light switch on her right.

REID. Here's the cue that we all know about, those of us who work switchboards. No sooner has the curtain gone up on the beginning of Act II with the moonlight and perhaps the flickering fire, than in comes the actress, over to the switch—the right one we hope—and flicks it on and we come up in dead synchronisation with the light. In this case it's a wall bracket. We've tried to make the light that comes on in association with the wall bracket to be fairly meaningful. We need a lot of co-operation from the Director here. One hopes that the first light the actors switch on is the one that they are going to play in for a moment before the scene fills out and here she's just put the light on and we've put on the backing in the area that she's in. This of course wouldn't keep us going terribly long, because other actors will come in.

Lyn is joined by Thelma and Barbara. Thelma esconces herself on upright chair D.S.R. while Barbara pours drinks at the table and Lyn seats herself close by on the settee.

Well, here they all are. . . . Now the light that's giving the excuse for the lighting—the key light we often call it—is the wall bracket but the lighting we had originally wasn't enough. Obviously we've done a cheat here. There are two kinds of cues: there's the fast cue that the audience sees, you know probably something up to about five or six seconds; then there's the slow one that they don't see. The first one was a fast cue—it was a snap, a switch-on, and now we've done the sort of cue that might last thirty to forty seconds—a very slow cue that the audience, if the play's good enough, will not be aware has happened at all. But we have begun to get ourselves enough light for the action. Frankly, looking at the stage now, we haven't done it very well because of the motivation of the light. There's a lot of the light seems to be coming from the audience's right whereas the fitting is on their left, but that's one of the difficulties of working with a small number of lanterns.

BENTHAM. Yes, and it's a very small number in this case—it doesn't look too bad to me and since all the characters are feminine the audience must be concentrating on other things in this scene—not looking at light motivation.

REID. Well this is one of the things one must beware of. I mean we stare at photographs like this as we might stare in a lighting rehearsal—while we think of things to do—but the audience aren't like that. We've come in to the show cold; they're seeing a live vibrant play with everybody moving *for the first time* so we mustn't be over subtle . . .

BENTHAM. No, you were talking of co-operation from the Director and I notice Richard Pilbrow also picks this up in his recent book—Directors should bear in mind that the circumstances of the lighting should give them the motivation for the action they are requiring. In other words, they shouldn't now want to play a long and deep emotional scene upstage at the back there, where it's dark. We have got the light here but the next thing, if the action's

going to spread at all, must presumably be to get some more light somewhere else . . .

The ladies are joined by Brian and Francis. Brian, businesslike, switches on the other wall bracket D.S.L. and seizes the 'phone. Francis with an eye to the main chance pours himself a drink and engages Thelma in animated conversation.

BENTHAM. And there is the excuse . . .

REID. Yes, that's right . . . to be provided of course by the Director; the lighting man can't get the members of the cast to go and switch lights on. If the Director knows he's going to use a certain portion of the stage then he must provide some sort of practical light and must get an actor to go and switch it on.

BENTHAM. I should point out that it is extremely unusual, even in amateur shows, to find the lighting man actually playing a part in the show and also the man at the switchboard. At the moment Brian Legge, our operator, is occupied in making a phone call—and from the stage! He ought to be at his switchboard all the time. Even if it's one of those scenes in which nothing happens, one shouldn't sneak out to the pub next door or anything like that because you never know, some sort of disaster might happen in the middle of the scene and you ought to be around at post of duty—black mark to Brian Legge—pass on . . .

REID. Assuming of course that Mr. Fred Bentham must be in the pub, because he wasn't in the picture.

BENTHAM. I was . . . I was directing it—yes, the Director shouldn't also act on the stage. Take a note of that Sir Laurence . . . oh, no, Lord Laurence!

The scene changes to the following morning. Lyn and Barbara are by the window waiting for the exchange to connect their call while D.S.R. Brian takes the opportunity to plead his cause with Thelma.

REID. This is daylight and all we've done to get daylight is to switch off the practical

lamps, and we've taken out the moon and we've changed it to the sun. We change moon to sun very easily by just taking the colour out. It was a Patt. 223, a nice lamp to use if you want a good flood from a Fresnel, which we did here because we were at close range—well we're always at close range on the small stage—and we wanted it to cover the whole of that window, so we used the Patt. 223. Now it's day and everybody's still lit. It's basically the same sort of thing. We might have the level a bit higher but the light's there. It's not there to do the natural thing in a theatre—it's there to do it dimensionally—to give it the bit of atmosphere. Basically, you're there to light the actors and whether it's a moon or whether it's day or whatever, isn't a matter of jiggling about with all the spotlights, it's just a matter of jiggling about with the key lights.

BENTHAM. I don't know whether we've told them what that window actually is. You see there's a strange shadow on the back? That's a bit of fernery hung up to cast a shadow and the window's actually draped with a sort of muslin, isn't it? So we're not looking at a backing, we're looking at a muslin across the window and I think perhaps some talk about windows might be suitable at this point.

REID. Yes. Well of course by using muslin on the window, we've opted out of our big problem which is shadows on the backing. If we didn't have muslin there, if we had a backing and we had it lit, we might well get shadows off the actors onto the backing. One wants to get enough light from the spots to light the actors and inevitably, as we can't just chop the beams off after they'd passed the actors, they'd go on through the window and make shadows on the backing.

We'd then say, "Just bring up the light on the backing." We'd do so but we'd get a silhouette effect and the actors would go dark again. . . .

BENTHAM. There's a lot to be said, is there not, for putting something in at window level. This is a more or less opaque muslin—you can't see through—but the business of just putting a frame with nothing between leads to all sorts of troubles, does it not?

REID. Especially actors putting their fingers through the glass.

BENTHAM. Yes, I've seen that happen. Of course there's another thing too, a favourite thing of mine—so as it won't be a favourite of yours, it automatically follows I will describe it. I do think that sometimes, where you've got just a simple backing outside the window or outside "French Doors Centre" which have to be opened, there's a lot to be said for putting a hedge or something—where the light lands up—so that the light doesn't go through onto the sky. After all light inside the room, if it were night-time, would go through and light anything immediately outside the window and this makes it a little bit more natural.

REID. You'll be surprised to hear that I actually agree with you. And it ties in with lining up your lights on say picture frames, door frames and so on. If you have a wall or a hedge then you can line the tops of the beams along the top of the wall.

The above is taken from our new Recorded Lecture, "Light on Stage Lighting" (available only in the U.K.). The set bears a strong resemblance to that used by Francis Reid when "Focusing" in the September issue.

DDM—A Revolution in Lighting Control

David Baker*

The Editor feeling that there was a grave danger of overfacing the public with Bentham, especially as he insisted on doing the Triptych article, has prevailed upon David Baker to take up the lighting control story with an engineer's description of the latest system DDM.

For several years now the name DDM has been something of a dream. Some less generous might say it had almost become a myth. However, speed and single-mindedness of purpose have over the last year resulted in the completion of the final stages of evolution. Let us therefore examine how and why we have arrived at this important milestone.

Firstly we need to understand two commonly used terms, namely "digital" and "memory". With a conventional control board, if a fader lever is moved from zero through lever position 1 to 2 and so on through to position 10, then its output will increase (in Rank Strand systems) from zero through to about 15 volts. The technical term "analogue" is applied to this voltage and implies that it can be varied smoothly over its full range and that its level can be simply measured with a meter. The voltage from the fader lever is of course used to control the output from the appropriate thyristor dimmer.

A memory control system is capable of recording the level set on the fader lever. Most people these days are familiar with the domestic recorder using magnetic tape in either reel or cassette form. In this type of instrument, a strong signal causes the magnetic tape to be more heavily magnetised than a weak one. However, anyone who has used this equipment will know that on re-play the level of the signal can vary widely according to quality of tape used, presence of dirt, tape speed and the design of the recording and playback heads. To the domestic user, this presents little embarrassment since any such variations can be taken up by adjustment of the volume control. However, a memory control system must be able to record a dimmer level, play it back many times and even re-record it, without change.

The problem is that magnetic materials

are not suitable for the accurate recording of levels unless special techniques are employed, one of which is to use a digital approach. Put simply, digital means that everything has to be defined in terms of simple, two-state criteria, i.e. ON/OFF or 0/1 or YES/NO, etc. With this arrangement, a level is represented by a number in binary code. A full appreciation of this subject really merits a separate article. It is however a sobering thought to find that one's nine-year-old son has been taught binary arithmetic as part of his normal school curriculum! For those of us educated in a supposedly less-enlightened age, a simple example will serve to illustrate the principles involved. Let us imagine that we had a system of coinage with only five pieces, which we used to represent $\frac{1}{2}$, 1, 2, 4 and 8 pence respectively. These coins could be identical in shape and size being distinguished merely by different "labels". Between them they would give us any monetary value from zero to 15 pence in $\frac{1}{2}$ pence increments. Similarly, five "dots" on magnetic tape can be used to represent any recorded dimmer level for 0-15 volts, depending upon which dots are magnetised. Thus the first dot would represent $\frac{1}{2}$ volt, the second 1 volt, the third 2 volts, the fourth 4 volts and the fifth 8 volts. These would give us any voltage value from zero to 15 volts in $\frac{1}{2}$ -volt increments. Thus dimmer voltages can only be represented in $\frac{1}{2}$ -volt increments.

With the digital approach, the accuracy required in recording and playback only needs to be quite crude since we simply have to determine whether a "dot" on the magnetic tape is magnetised or not or

*Chief Engineer, Rank Strand Electric since December 1969. Prior to this he was Technical Manager of Elliott Automation's Space and Guided Weapons Division.

whether a transistor is switched on or off and so on.

To arrive at a digital (coded) signal, the dimmer voltage has to be "translated" by a piece of electronics known as an analogue to digital converter. This circuit has one input connected to the dimmer voltage and has five output wires carrying the coded digital signal. Extending the argument of the previous example, six output wires could be used in which case the 15 volts could be covered in $\frac{1}{4}$ -volt increments. This would be known as a six bit system.

Once an analogue voltage has been converted to digital, many forms of recording media using ON/OFF techniques can be used. For instance, a ferrite store is made up of a large number of minute rings of magnetic material (ferrite) which can be magnetised or de-magnetised. The five wires carrying the digital signal would be connected to five of these cores so that one circuit dimmer level can be recorded. Similarly magnetised dots can be set up on magnetic tape or holes punched in paper tape—they all serve a similar purpose.

Strand Electric led the world in producing System IDM, the first instant dimmer memory control designed specifically for theatre, and has consequently had to suffer some of the misfortunes and setbacks which frequently accompany the first adventurer who too hastily enters a new field. With the takeover by the Rank Organisation in November 1968 there inevitably followed a period of marking time while the new setup got its bearings, but one year later, after recruitment from the computing and aerospace industries, Rank Strand was ready to begin the large task of updating the logic circuitry for the many IDM systems¹ already installed in or on order for various countries of the world. In the United States a similar system, called Memo-Q, is manufactured and marketed by Century Strand. Both systems make use of digital stores and other techniques.

At the same time the next generation of controls had to be envisaged. For this a pilot project was given the code title of

DDM which as is the way with such things has stuck. The first "D" stood for digital and was intended to imply that the major part of the operating logic and of course all the storage and playback would remain digital with the minimum of conversion to analogue.

When compared with DDM, the IDM/Memo-Q type of equipment is more or less conventional from both the operational and engineering points of view. Figure 1 shows a simplified schematic of the arrangement. The terminology used to describe each store (Main store, Local store, etc.) has been deliberately adopted in order to make description of the DDM system more readily comprehensible by comparison.

During rehearsal in the case of IDM/Memo-Q, the required lighting levels are set up on a series of potentiometer-type fader levers one per channel. The levels are memorised by first converting from analogue to digital and then recording in the Main store. During playback, recorded cues are recalled (normally in sequence) on to one of the two Local (playback) stores labelled C and D in the diagram. The outputs from these two stores can be proportioned by the playback master controls. The final output on each channel is converted from digital to analogue to provide the control signal for the dimmer. Thus the operation is similar to that of a two preset manual control except that in order to set up each preset in turn, the operator requires merely to recall recorded scenes onto alternate playbacks.

The terms Store and Memory are synonymous, and the former will be used in this article. A store is a device in which digital information can be recorded and recalled when required. A number of different technologies are available for the construction of the store and many popular myths have been created to give apparent virtues to one type or another. However, the decision as to which technique is used is largely a question of economics. As technology advances, the user can expect the type of storage medium to change in order that cost advantages can be passed on.

The Main store is designed to contain one or more complete shows and will

¹The latest version is known as System MSR.

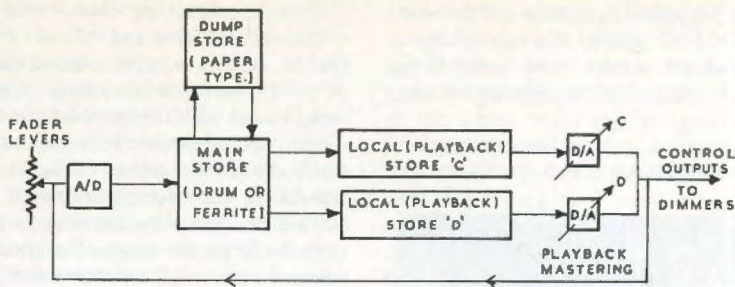

FIG. 1. SIMPLIFIED SCHEMATIC OF IDM/MEMO-Q TYPE OF SYSTEM

usually be in the form of either a magnetic drum or a ferrite core assembly. Figure 1 also depicts a "Dump" store. When the Main store becomes full, it is desirable to "dump" one or a number of recorded shows on to either paper or magnetic tape for shelf storage. The Local stores being smaller (one cue only contained in each) would normally be constructed from transistor or integrated circuit elements, or alternatively would use a small ferrite store.

The other salient feature of the conventional type of equipment is the "hardware" logic concept. In early electro-mechanical systems, relay combinations were used in order to determine operational characteristics. When an action button was depressed, relay contacts would be operated and timing circuits activated in order to perform the required operation. With modern equipment, high-speed electronic circuitry is used to perform these functions, but the principles are still essentially the same, i.e. operation of the control button activates the appropriate electronic relays (logic) and causes timing and sequencing circuits to operate. Each of these circuits is designed for its specific purpose and any change required in the operational performance of the system, however minor, necessitates an alteration to the design of the manufactured hardware (i.e. printed circuits, wiring, components, etc.).

The adoption of a "hardware" technology has important ramifications. Firstly, the design of complex operational facilities not only becomes hazardous from the standpoint of development, but also, there is an economic limit on how much special pur-

pose circuitry can be incorporated into an equipment in order to achieve a required specification. Secondly, the design of control boards to suit different operational requirements or to meet special functions demanded by individual users may necessitate radical changes to manufactured hardware. Thirdly, the only way to develop new systems and improve operational facilities is to be continually changing hardware. This clearly mitigates against standardisation in terms of works throughput, spares, stockholding, etc.

How therefore were we to meet the sophisticated performance requirements laid down in the specification for DDM? Before answering this question, let us examine the operational features which characterise this equipment. One of the drawbacks of the fader lever in a memory system is that when one requires to modify a channel in playback the lever is unlikely to match the dimmer level as recalled from the memory and in consequence, before switching over, matching of level has to take place. If it is recognised that using a memory system the operator will seldom need to know the precise level of a channel, since he neither has to plot it nor manually to recall it using a plot, then it becomes possible to consider a non-positional channel control. One such device is the centre-sprung rocker tablet used for the two memory installations supplied by the then Strand Electric to the National Arts Centre in Ottawa. The rocker operated in conjunction with hardware logic made for that firm by Sperry and has been found to have considerable merit for the purpose of channel control. The rocker was therefore

decided on for channel control on the new system DDM to enable the operator to have immediate access and overriding control with integral mimic display on any channel.

For playback, comprehensive action controls were required which would enable

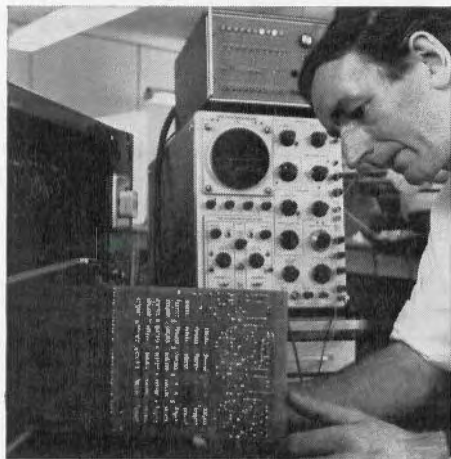

composite scenes to be prepared as the summation and/or deletion of any number of memories. Two completely separate playback masters were demanded, each with independent up and down fade rates. Copy facilities were to be provided between playbacks, and playback action controls would be such that a lighting director could make immediate demands for the type of fade to be changed, terminated or even reversed, no matter what type of fade was taking place.

In fact the whole concept of DDM, besides giving the operator comprehensive recording and playback controls, is to provide him (or the lighting director) with easy means for modifying the recorded plot to facilitate last-minute changes during rehearsal and to cater for the unpredictable during the show. In technical parlance one might say that DDM has been designed to permit a very high degree of man/machine interaction. However for such a thing to be possible it is essential to have comprehensive mimic facilities in order that the operator can be made constantly aware of the operations and changes which he has made.

From the development point of view, one of the difficult features of such a system is that to define on paper every logical aspect of performance is an almost superhuman task. Faced with this problem and with the difficulties of development along conventional hardware lines, thoughts naturally turned to the incorporation of a digital computer. Memory lighting control systems have in the past often been loosely referred to as "computerised" lighting controls. However, although such systems use electronic circuits similar to those employed in computers, the description is strictly only applicable if the system incorporates a programmable computer. To the best of our knowledge, DDM is the first such equipment to be developed in Europe.

Before looking at the technical aspects in more depth, it is worth examining the human side of the story. The DDM operational concept had been originated by Frederick Bentham and was realised in a very simplified 16-channel pilot project. This was completed and tried out



in the Head Office Demonstration Theatre in May and June 1970. The work was carried out under the direction of an outside consultant working with a small but experienced Rank Strand team headed by Ron Eason. During the summer of 1970, plans were discussed for the development

within the by then strengthened Rank Strand E.R. & D. Department of a full-scale system capable of controlling up to 360 channels. The original Rank Strand team was reinforced by Dick Gascoigne (from International Computers Limited), Tony Payne and Mike Day. It was decided that Dick would undertake the development of software (programming) and Tony, with his combined engineering and operational experience, would liaise with Frederick Bentham in order to establish just what the control was to do and to up-date this as development proceeded. Mike Day took charge of mechanical design.

In September 1970 the operational specification was prepared, and during that month and early October a system study was carried out. This proved to be the most crucial part of the development programme. We had decided to use a proprietary computer and it had to be of a realistic price, adequately proven, backed by worldwide servicing facilities, and of course functionally suitable.

However, by far the most difficult problem was to determine how the computer would handle simultaneous crossfades on up to 360 channels, bearing in mind that there were also two playbacks and separate up and down crossfade speeds. The computation techniques which had been used for the 16-channel prototype were unsuitable and an entirely new approach had to be found.

After much "head-bashing" the problem was resolved with one of those simple but elegant solutions which come to a designer but once in a lifetime. It is Rank Strand's unique answer to this problem that has given DDM its tremendous versatility and dynamic capability.

Detailed technical and management planning, carried out during September/October last year, has enabled the project team to pursue the development in what must be an all-time record. As the result of using a computer to control the operational functions of the system, it was possible safely to complete the hardware design before the operational specification was finalised. The system was designed,

made to full manufacturing standards and tested by early February 1971! There followed a period of system testing and program "de-bugging". It is much to the credit of the whole team that programming and full-system tests were completed by May this year, following which numerous demonstrations have been given, including one to the Press at the end of July. At the time of writing the team is engaged upon the design and programming of a Stalls Control, together with the completion of more mundane production engineering tasks.

Many computers in the £2,000-£6,000 price range have been available now for over ten years. However the last two or three years have witnessed the introduction of a new generation of machines in which considerable ingenuity on the part of the manufacturers has resulted in a twenty- or thirty-fold increase in effective performance for only marginally higher cost. It is this development which has made DDM both technically and commercially feasible, the computer used being Digital Equipment Corporation's PDP11 of which over 1,400 have been sold in the 18 months following its introduction in January last year.

So much for history. Let us now examine in some detail the role of the computer in DDM. Earlier in this article we have seen how in the case of a conventional system, a switch or push-button on a control panel is directly connected to the electronic logic and/or timing circuits which cause the appropriate operations to take place. However in DDM, operational switches and buttons are connected to a computer as is shown in Fig. 2. The best analogy which can be given is to imagine the computer as being at the hub of a high-speed electronic (telephone-like) exchange with each control, mimic light, dimmer output and so on having an individual telephone number (or "address" in computer parlance). When a push-button on a control desk is depressed, it has to wait its turn until the computer calls up its identification code on the address line whereupon information is relayed back along the data lines to advise the computer whether the

push-button is open or closed. In this manner the computer is able to interrogate each control at least twenty-five times per second. Similarly, if a mimic light is to be illuminated then its corresponding address will be set up by the computer and the outgoing data line will be energised. Obviously this is a completely different concept from the conventional system.

Having seen how the central brain (computer) communicates with each part of the system, it is possible to examine how the lighting control functions are performed. A much simplified schematic of the system appears in Fig. 3. This shows that the address and data lines described above are used to interconnect the computer to every part of the system. The computer itself comprises three main assemblies, viz:

1. Central processor.
2. Programme store.
3. Local store(s).

It is the central processor which performs the computing operations, the most important required for the DDM system being:

- (a) To act as the nerve centre of the electronic exchange, connecting each

part of the system to the computer.

- (b) To retrieve, modify and sort files of recorded cues (the Main and Local stores are used as the files).
- (c) To perform arithmetical operations such as addition, subtraction, multiplication, etc.

The first two of these functions are self-explanatory. Arithmetical operations are required for instance when one cue is added to another (ADD NEXT function) and also during the crossfades when a pseudo-multiplication is performed.

The Local store configuration basically comprises the following:

1. Next store.
2. Destination store.
3. Output store.

The memories which go to make up the next scene are placed in the Next store. Where the ADD NEXT function is used, the "greatest takes precedence" principle is applied. Destination defines the end-of-fade conditions. This can only be determined after the type of fade required has been selected (i.e., CROSSFADE, MOVE OR DIM). Using this information the computer can up-date the levels fed into the Output store as the fade proceeds. From this

description it is apparent that the operation is completely different from the IDM/Memo-Q principle of two local playback stores with simple mastering.

To add to the complexity it is required of DDM that if channel levels are modified by a rocker then the previously unmodified levels still have to be retained in case the operator should wish to return to the original state. Furthermore, a cut facility is incorporated and stores have to be duplicated in order to provide two independent playback and recording controls. It is this high degree of sophistication that characterises DDM but it necessitates no less than eleven Local stores!

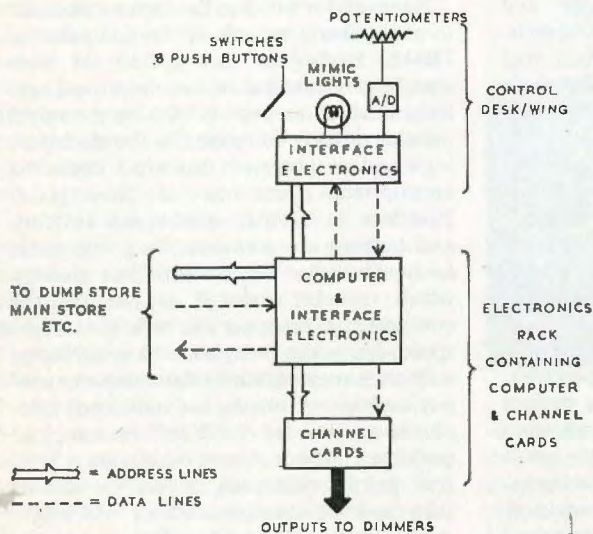

FIG. 2. CONNECTION OF CONTROLS & OUTPUTS IN A COMPUTER-CONTROLLED SYSTEM.

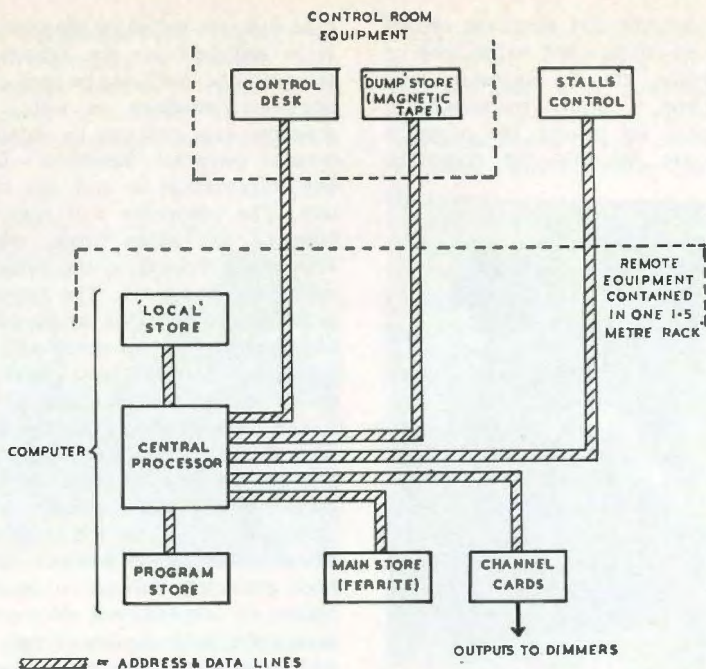

FIG. 3. SIMPLIFIED SCHEMATIC OF DDM HARDWARE

Fortunately, these are both easily and economically accommodated in the ferrite store contained within the computer. Although from the operational point of view this contains a number of stores, it tends to be generally referred to as the Local store in view of its composite construction.

Let us recap. We have provided the system with a central processor capable of performing all the necessary operations, and have connected it to all parts of the system by means of a high-speed electronic exchange network. Connection has been provided not only with the Main store but also with a high capacity Local store in which the computer can temporarily file away the cue and mimic levels which it requires for current reference. This however only represents capability. The computer must now be instructed to interrogate each control in turn and to carry out correctly whatever is demanded by the operator. For instance, part of the instruction sequence would read as follows:

1. Address the top contact of Rocker 28

and see if it has been depressed.

2. If *no* then proceed to top contact Rocker 29. If *yes* then enter "Rocker routine".

The computer cannot think for itself, but given simple rules to follow it can be conditioned to carry out alternative courses of action. Thus, if the top contact of Rocker 28 had been depressed then the instructions would have told the central processor to carry out a small "sub-routine" of instructions which would cause the level of the channel dimmer to be raised in response to the operator's command. This having been completed, the computation would then return to the routine interrogation of the remaining Rockers and other contacts. This set of instructions is referred to as the "Program" or "Software".

It is on the subject of software that many popular misconceptions arise. The program for DDM consists of over 4,000 instructions which determine what action the computer must take when each control is operated. This program has been designed

during development and exists on record either as a reel of punched paper tape or as a recording on a magnetic tape cassette. When a newly manufactured system is ready for testing, the program instructions are fed into the computer



Program store using either a paper-tape or magnetic-tape-cassette reader as appropriate.

However, program entry will normally be a once-and-for-all operation carried out during works testing. A special keyswitch has to be operated on the computer to allow the program to be entered. Once having accomplished this the switch is returned to the Off position and the key is removed. All the panel switches on the computer (used only for maintenance purposes) now become completely inoperative and the program will now be retained permanently inside the computer.

The bare computer without its program is a standard, but highly ingenious, "black box" capable of carrying out a wide variety of operations. By entering the program, we convert it into a special purpose machine able to perform the control functions specific to DDM. From this point on, the mechanism of how the system came into being can be forgotten and the computer can be regarded as any other piece of electronic equipment with electrical input and output terminals.

In fact, the self-same magnetic tape unit as is required for the Dump store for recorded cue levels can be used to enter the computer program as well. Thus, the magnetic tape unit can be regarded as the general purpose "letterbox" for getting any information in and out of the system. The computer will route recorded cues to the Main Store, whereas the Program is routed to the Program Store inside the computer. The man who prepares the program (the programmer) would not normally be involved with the user other than to check any special functions which may have been requested.

The sophistication of DDM operation is such that a conventional hardware design to meet the same specification would have been phenomenally difficult and costly. This is illustrated by the large number of Local stores required which would have been extremely difficult to manipulate by means of conventional electronics. However, there are a number of very important additional advantages which the design of DDM brings to the user.

Firstly, the computer and the Main Store (which form the heart of the DDM



system) are both proprietary items, manufactured in large quantity under stringent conditions of quality control. Although they have both achieved an excellent reliability record, spares and maintenance facilities are available from the manufac-

turers on a world-wide basis. Secondly the system will eventually be provided with self-test facilities whereby the user will be able to harness the computer to carry out a simple point by point check on its own



behaviour and the continuity of all controls and connections. Thirdly, by using the software/computer technique, problems of equipment obsolescence are made minimal. Any refinements made to a program can be made available to existing users simply by inserting the modified program during an annual service routine. Furthermore, Rank Strand can continue to develop this type of system for other applications using the same basic electronic hardware. This will undoubtedly have ultimate benefits to the user in so far as spares availability and system costs are concerned.

The computer gives the system enormous capability in terms of complex functions and also the ability to extend the system to cover additional channels and/or facilities. Although interest in DDM systems as small as 90-ways has been expressed by potential users, it would be difficult to justify its use as yet in such a small installation on purely commercial grounds. However the incorporation of the computer pays off handsomely as the number of channels and facilities are extended. Thus a tape cassette unit or stalls control can be incorporated at relatively modest cost despite their operational comprehen-

siveness. This virtue is attributable to the fact that whilst the data and address line structure needs to be extended to connect each of these additional peripherals, their functional operations are controlled by the computer which is already incorporated in the system.

Lastly, whilst for commercial reasons it is desirable to standardise on a limited number of variants of the system, nevertheless, it is feasible to consider specific operational variants as required by individual users. Special programming would have to be undertaken in each instance and the cost of this might have to be borne by the user. In fact it is fair to say that many of the advantages which the computer



brings have only been perceived during, or subsequent to, the design of the DDM equipment. Hardly a week goes by without some further advantage or possibility becoming apparent.

One cannot help but sense that we have only just begun in so far as future possibilities and opportunities are concerned. The inherent capability of the computer is so enormous that such functions as group mastering, the recording of crossfade times and the control of sound effects, slide change mechanisms, servo positioning and focusing systems for spotlights and so on

are all readily amenable to future development. Put another way, we could certainly see—inside the next decade—one computer being used to control not only the lighting but also the box office. It is no longer so much a question of what can you do but rather what do you want to do!

System DDM is made under Patents and Patents applied for. We shall be describing an important theatre installation of DDM in detail in our next issue.

Pre-set spots and other Irregularities

The Stage Guide. Compiled by Michael Holden in conjunction with the A.B.T.T. Published by THE STAGE Newspaper £4.50 incl. postage in UK.

Reviewed by the Editor

If I had had to reply to Roy Plomley's question as to what book, excluding the Bible and Shakespeare, I would take on that desert island along with those ten gramophone records I would have said either *Bannister Fletcher* or *The Stage Guide*. Being a practical man—another of his questions—the choice would have been the latter because the weight of "*The History of Architecture on the Comparative Method*" would have sunk me before reaching the shore.

The Stage Guide of 1946 was a dim green volume of 200 pages or so but packed with intriguing information in small print, some of it very strange indeed. There were things called "F.O.H. Pre-set Spots" about whose nature or even existence their owners seemed uncertain. The New Theatre claimed "four" whereas the Palladium, which had sixteen with 4-colour remote change, did not consider the spots worth a mention. The Savoy announced "automatic colour change" with their six but did not realise that they were one-up on the others because theirs were Mirror spots. "Four floods on stands" and, in at least one case, "one flood on stand" were scheduled with pride. One was reminded of the entries in *Who's Who In The Theatre* where length is not so

much a matter of merit or worth but rather a reflection of the amount of trouble the entry himself was prepared to take.

Then again on the matter of "Prosc." height there seems to have been great indecision as to where to drop the tape-measure from. Such other dimensions as turned up were so irregular as to defy study on the comparative method! Sir Bannister himself would have been vexed but even in his case one suspects he had to content himself with what came to hand rather than what he would like and this too was obviously the case with the Guide.

Nevertheless I found the *Stage Guide* of '46 a very valuable companion and, thanks to its closely-packed pages, developed the habit of always visualising a theatre name as a pros. (or rather as *The Guide* put it "a prosc") width and a seating capacity spread over a number of tiers. Just to compare two theatres at random will show what I mean. The New Theatre—31 ft. 6 in. with 741 seats on four tiers and the King's Hammersmith—32 ft. 6 in. but 1,566 seats over three tiers only. Then again the great stages of Drury Lane and Covent Garden were pinned down for ever as just over 40 ft. and the London Coliseum as impossibly wide at 54 ft. 10 in.

In recent years Michael Holden has been methodically garnering theatre statistics and a happy combination of this painstaking editor with the members of the ABTT has produced an entirely new "super" *Stage Guide* of some 400 pages.

The choice of a certain theatre of all the theatres in the Guide as décor for the cover must cause its architect to wonder whether this was because it represented a mid-course between ancient and modern or whether it was because it bears the name of our great and much loved actress now in her ninetieth year.

The ABTT form was sent to all "professional" theatres in the British Isles—a fearsome, printed spread of the questions to which practical men need answers when assessing what a theatre is like in which to put productions on (and when necessary get them in and out). The result is here for everyone to see—a page to each theatre. Since the page format is the same in each case the comparative method becomes possible; furthermore the difference in form of each theatre proclaims itself. Critical comment, necessarily a subjective thing, as to the success or otherwise of the architecture or the facilities is absent; nevertheless with a little thought a vision of the theatre comes off the page. One sorrow, the dimensions are in metric as indeed they have to be since—like it not—we are going metric this year, next year, sometime but alas not never. There is however a conversion table at the back.

There are three appendices listing theatres in order of Seating capacity, Proscenium width and by Towns alphabetically. What is a theatre within the meaning of this book? Some idea of the comprehensiveness of its terms of reference is shown by the fact that the largest theatre scheduled is the Scarborough Open Air at 7,000 seats and the smallest that at Mull with only 35 seats. In between come such places as the Royal Albert Hall at 5,606; the Regal Edmonton, a relic of the super cinema days with 2,462 seats, a pros. of 56 ft. wide by 31 ft. 6 in. high and stage depth of 43 ft. 6 in. and with a 65 ft. grid of 69 single purchase counterweight sets. There are also

well-known amateur theatres like Ealing Questors, Highgate Mountview, Middlesbrough Little and Birmingham Crescent. Nor are those strange structures on the end of the pier omitted.

This is third of the *Stage Guides* proper and it is interesting to note that the first, published in 1912, put the Provinces at the beginning of the book and London at the end. Touring was obviously a major preoccupation and instead of named switchboards there was, in many instances, named accommodation. I can detect however no symbol for "quoth the raven" in this respect. Another splendid appendage to keep actors out of mischief was to list the local golf course. It is a sad thing that nowadays a company will be attracted to the Empire Sunderland because of its "Strand CD 120 lighting control" rather than for "the magnificent new Queen Alexandra Bridge" or "St. Peter's Church Monkwearmouth, one of the oldest in the Kingdom" or "the fishing" which "can be indulged in from the old North Pier, and also, under certain conditions, from row-boats obtainable on the beach".

This new *Stage Guide* is a book as much for the lover of theatres to dip into as for its more obvious target, those who must have such technical details with which to work and I include in this latter class anyone designing a new theatre. There is no better way of putting a size to the visual imagination than to pin an exact dimension to something that exists and which one can go and see.

No theatre library can afford to be without the new *Stage Guide* on its reference shelves and this goes as much for those in American Universities as ours over here.

There remains the problem of keeping the Guide up to date and in this respect one is happy to say that the new theatres may well outnumber the closures. It seems impossible that a reference work so well begun will be allowed to lapse and an obvious interim solution might be the publication in *The Stage* itself and in the *ABTT Newsletter* of schedules exactly to this format as each new theatre comes along.

Correspondence

Cockpit-in-Court

Dear Sir,

Mr. Iain Mackintosh in his article *Theatre History and Theatre Architecture* published in your June issue (Vol. 29, No. 2) kindly refers to my recent findings relating to the Cockpit-in-Court at Whitehall Palace which was remodelled by Inigo Jones on the instructions of Charles I in 1629 and opened on November 5th 1630 by the King's Men.

In the footnote on p. 60 the reference to this recent work is given as *Elizabethan Theatre*, a collection of Essays and Papers published in 1969. This is incorrect. The findings, which tie drawing No. 27 in the Library of Worcester College, Oxford to this theatre and establish both the date of its opening and the fact that it possessed no "inner stage" were first published in *New Theatre Magazine*, VII No. 2 (Spring) 1967 pp. 26-35, under the title "The Cockpit Reconstructed". This article was subsequently reprinted in *Shakespeare's Dramatic Heritage*, 1969.

In view of the importance of the detailed information we now possess about this playhouse to all future study of Shakespearean playhouses, your readers may find it useful to be provided with an up-to-date handlist of recent scholarly comment on the drawing and the building. In addition to my own article quoted above there is Prof. D. F. Rowan's essay "The Cockpit-in-Court" in *Elizabethan Theatre* (ed. D. Galloway, 1969) and W. D. Knyper's article, "Two Mannerist Theatres" in *New Theatre Magazine*, XI, No. 3 (Summer) 1969. There is also Professor G. E. Bentley's lengthy discussion of the building and its uses both before and after the Restoration in Volume VI of *The Jacobean Caroline Stage*, pp. 267-84, (1969).

One problem which has hitherto defied solution about the exact lay-out of the building relates to the staircases, for the Jones/Webb drawings are ambiguous about whether they ascend or descend and where they terminate. However, with the assistance of the Dankerts painting of the exterior of the building I have now been able to resolve this problem and have set out my new findings in Vol II (Part 2) of *Early English Stages* to be published this autumn.

Since we now possess a full set of architects drawings (complete with scale) of the interior of this theatre, a painting of the exterior, and a full list of the interior fittings it is obvious that if any playhouse of the period warrants full-scale reconstruction it is this one.

Yours sincerely,

GLYNNE WICKHAM
*Professor of Drama & Dean of the
Faculty of Arts, University of Bristol.*

Academic Theatre

Dear Sir,

I am sorry that Mr. Percy Corry's article "Academic Theatre" in the last issue of *TABS* has misrepresented the facilities of the Allardyce Nicoll Studio and has not paid attention to certain factors that governed its design and equipment. Mr. Corry says that "Flexibility was again a stated requirement", but this was only one of the requirements. The architect and theatre consultant and the staff of the Drama Department at Birmingham were also concerned with economy in a studio theatre serving an academic department. The complicated punched-card system and the 100 dimmer channels were designed so that three productions could be prepared during the slack time of vacations and manned with only one technician. The Studio was provided with elaborate projection equipment in order to allow the performances of a variety of plays to have appropriate visual settings without the cost of three-dimensional scenery and without the labour involved in changing that scenery. Indeed, the Drama Department hoped that the Studio would be able to play some part in devising techniques of presentation that would be far cheaper in man-hours than those productions dependent on conventionally constructed and painted scenery.

There are one or two errors in the article which I would like to take this opportunity of correcting. Its name is not the Allardyce Nicoll Drama Studio but the Allardyce Nicoll Studio. For proscenium or open end-stage, more than half of the seating is *not* on the flat floor. Not all the six permanently tiered rows have fixed seats and so by the use of rostra it is possible to have all but two or three rows of seats appropriately tiered.

Mr. Corry concludes by suggesting that the Allardyce Nicoll Studio has been lavishly equipped. Rather, in my opinion, it has been designed economically. There is no flies-tower and no wing-space. Sophisticated lighting installation allows for economy of manpower in operation and enables the Studio to specialize in cheaply created settings using lighting equipment still comparatively new in the British theatre.

Yours faithfully,

JOHN RUSSELL BROWN
University of Sussex
(formerly Head of the Department of
Drama and Arts Birmingham University)

Correction

In our June issue a footnote on page 60 referred to Professor Glynne Williams. It should of course read Professor Glynne Wickham.

Synopses

Stalling or Immobility

Contrairement à ses affirmations passées, l'Editeur conteste la tendance actuelle d'installer un jeu d'orgue dans les loges de théâtres, où existe déjà une position favorable de l'auditorium.

Der Redakteur scheint von seinem gewöhnlichen Standpunkt abzuweichen, indem er die moderne Tendenz kritisiert, Stellwerke in Logen unterzubringen, wiewohl ein anderer, ausreichender Platz im Auditorium eines Theaters schon existiert.

Scarecrow or a Scaley Problem

Le succès de bons spectacles présentés dans le cadre d'apparent dénuement de certaines caves de clubs ou restaurants est indéniable. L'Editeur s'interroge: Y aurait-il lieu de déshabiller nos théâtres plutôt que de les habiller? Le succès de certains théâtres "dénudés" semblerait le suggérer.

Der Redakteur bemerkt, wie beliebt gute Aufführungen in anscheinend bescheidenem Rahmen in Clubs und Restaurants in Kellern sind. Sollten wir es vielleicht unterlassen, unsere Theater aufzumöbeln und sie stattdessen "heruntermöbeln". Der Erfolg manches "armen" Theaters scheint darauf hinzuweisen.

Gunnersbury

Nécrologie d'une vieille usine sans: a quelle les présents développements n'auraient peut-être jamais été possibles.

Nachruf an eine alte Fabrik, ohne deren Mitwirkung der Erfolg der Firma nicht möglich gewesen wäre.

Triptych

Frederick Bentham examine l'expression architecturale de l'orgueil civique dans trois théâtres: The Wyvern, Swindon, The Crucible, Sheffield et le nouveau Birmingham Rep. On peut se demander si, dans ce conflit de courbes et de lignes, les désirs de l'auditoire sont jamais pris en considération.

"Bürgerlicher Stolz durch Architektur ausgedrückt" ist die Bezeichnung, die Frederick Bentham den Theatern Wyvern in Swindon, The Crucible in Sheffield und dem neuen Birmingham Repertory Theatre gibt. Er überlegt, ob zwischen den runden und geraden Linien der Architekturstils, die Meinung und der Geschmack der Zuschauer jemals gesucht werden kann—jemals zur Geltung kommen kann.

Cutting your Shape to suit your Show

Entretien avec Peter James sur le succès de la Young Vic Company après une année passée dans le nouveau théâtre de Frank Dunlop, à la rue Cut (400 places). Une simple scène en éperon avec un strict budget.

Eine Diskussion mit Peter James über das erfolgreiche erste Jahr der Young Vic Company in Frank Dunlop's neuem Theater in einer Strasse die sich the Cut nennt. Dieses hat 400 Sitze eine einfache, spornförmige Bühne und ist mit ganz bescheidenen Geldmitteln ausgestattet worden.

MacRobert and Brunton

Francis Reid se réjouit de voir une acceptation plus générale des consultants du théâtre et applaudit la construction de nouveaux théâtres en Ecosse. Le MacRobert, Stirling, un théâtre d'avant-scène, a les avantages d'un cadre magnifique et est dirigé par une compagnie avisée. Le Brunton Theatre, Musselburgh, de son côté, est une construction originale et imaginative.

Francis Reid freut sich, über das anwachsende Mass, in dem Spezialberatung für Theaterbau und -ausstattung angewandt wird. Er begrüsst auch zwei neue Theater in Schottland: Das MacRobert Theater in Stirling, in schöner Umgebung gelegen mit zielbewusstem Ensemble und das Brunton Theatre in Musselburgh mit seinem unkonventionellen, fantasievollen Baustil.

DDM—A Revolution in Lighting Control

David Baker, chef du Département des Recherches et Développements de Rank Strand, décrit à l'intention de l'ingénieur comment son équipe harnacha un computer standard pour satisfaire la nouvelle génération de jeux d'orgue scéniques.

David Baker, Vorstand der Abteilung für Forschung und Neuentwicklung erklärt dem Ingenieur, wie er mit seinen Mitarbeitern einen normalen Computer für die neue Generation von Stellwerken eingespannt hat.

Pre-set Spots and other Irregularities

Frederick Bentham a lu pour vous la nouvelle édition du "Stage Guide", publiée en collaboration avec l'"Association of British Theatre Technicians".

Kritik von Frederick Bentham der neuen Auflage des zusammen mit der Association of British Theatre Technicians herausgegebenen Buchs "Stage Guide".

Correspondence

John Russell Brown, ancien responsable du Département dramatique de l'Université de Birmingham, répond à l'article de Percy Corry sur le Allardyce Nicoll Studio. Prof. Glynne Wickham ajoute quelques notes à propos de l'article de Iain Mackintosh "Theatre History and Theatre Architecture".

John Russell Brown, früherer Mitarbeiter in der Drama-abteilung der Universität in Birmingham beantwortet Percy Corry's Artikel über das Allardyce Nicoll Studio Professor Glynne Wickham fügt Iain Mackintosh's Artikel "Theatre History and Theatre Architecture" einen Beitrag zu.

Rank Strand on the move

Rank Strand Electric announce changes in address consequent on the completion of their plan of rationalisation and the concentration of lighting and control equipment manufacture in the new factory at Kirkcaldy.

In London the Hire Department will move to the opposite side of Kennington Lane to be alongside the existing Sales Counter and Stores at No. 250.

In Manchester the remaining part of the premises at Gorton will be closed and its various departments transferred to Church Lane, Lowton, Near Warrington, Lancs. The transfer and reconstruction of the demonstration theatre will take a little time and it is regretted therefore that the usual programme of lectures in Manchester cannot be arranged for January and February. It is hoped to

restore these in March.

In Scotland, February 1st, 1972, will see the removal of Rank Strand Electric from their old premises in Sauchiehall Street, Glasgow, to 104 Hydepark Street, Glasgow. This will mean far better facilities for Scotland including their own demonstration theatre with car parking and is yet another step in our scheme to improve service and representation outside London.

It has been found that seating can best be handled by direct customer contact from Lowton where it is manufactured. The show-room space thus released in our Covent Garden Head Office will be used to provide a more appropriate setting for the demonstration of kinetic and lightshow equipment and for displays of Architectural Lighting.