

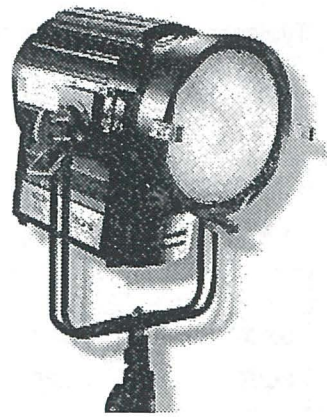

HMI 6 kW Daylight Fresnel

- Specifically designed 450 mm diameter lens provides superior optical performance
- Improved light quality and output, producing flatter and more even field
- High quality, rugged, durable
- Corrosion resistant
- IP23 rated, so the unit can be used outdoors in humid conditions
- Compatibility of parts throughout the range
- A comprehensive range of accessories, interchangeable with existing Quartzcolor products
- Easy to service and maintain
- ON-OFF buttons, operated from both head and ballast
- Bonding eyes and rigging hooks
- Front and back focusing
- New focus system, easy to adapt from manual to pole operation and maintenance-free
- Quick release lamp holder
- Easy running barndoor ears
- Hour counter
- Scratch resistant, black, non-reflective housing
- All heads supplied with barndoor, colour frame and head to ballast cable
- Meets all relevant international standards and regulations



Operational data

Safety:
A microswitch system prevents the lamp operating if the front section is open.

25 x 25 mm wire mesh guard.

Accessory fitting:
Cast aluminium ears.
Spring loaded top catch for retention of accessories.

Tilt adjustment:
Pivot located at centre of gravity for excellent balance and positive locking.

Focus adjustment:
Front and rear focusing knob for smooth and precise action from spot to flood positions

Lamp access:
Hinged lens door allows easy access for lamp replacement.

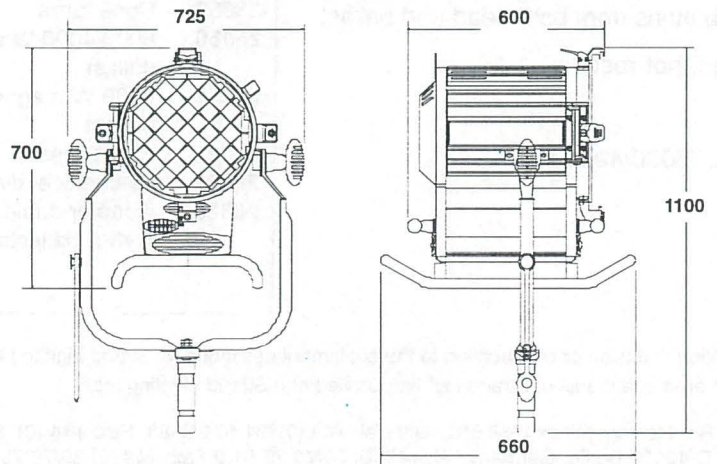

Weights & dimensions

Lens diameter	450 mm	Weight (head+stirrup+skid)	60 kg	Packed volume	1000x800x880 mm
Accessory diameter	550 mm	Packed weight	111 kg	Ballast dimensions	
Filter cut size	540x540 mm			p/n 25060	356x266x495 mm - 30 Kg
				p/n 25260	488x388x635 mm - 60 Kg



Photometric data

Typical performance based on 6000 W HMI lamp:

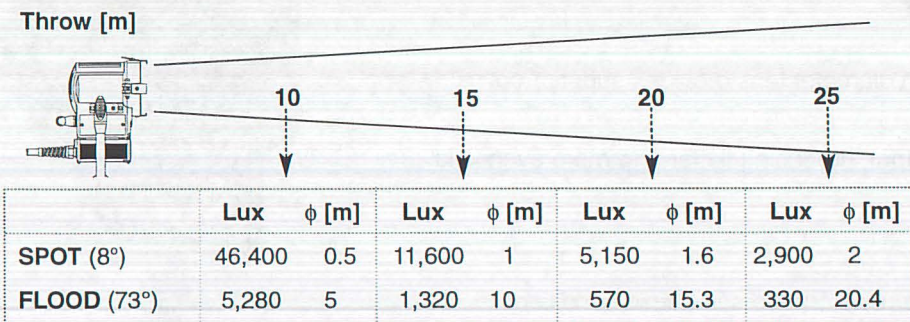

Lamp data

HMI/MSR 6000W single ended

LCL (mm)	210
Base	G38
Lumens	650,000
Rated life hours (H)	300
Colour temp. (H)	5600

Mechanical data

- Paint / Finish:** Powder coated epoxy paint with special extra high temperature treatment in critical areas. External textured low gloss finish
- Lamp house** Stainless steel with aluminium extrusions and die cast components
- Lamp holder** High voltage with quick release pin clamping
- Mounting:** Robust tubular steel stirrup with standard DIN socket

Environmental data

- Max operating ambient temperature:** 45°C
- IP Rating:** IP 23
- Tilt recommended angle of use:** -60° / 0 / 60°

Electrical data

- Switching:** ON/OFF double pushbuttons from both head and ballast
- Ignitor:** Compact, high-voltage, hot restrike
- Ignition voltage:** 65 kV
- Ballasts:** Electronic flicker-free, 6000/4000 W
Magnetic 6000 W
- Standards compliance:** CE marking

Ordering information

Cat. No Description

- 27913** HMI 6 kW bare head with stirrup
- 27080** HMI 6 kW supplied with stirrup, 4 leaf rotating barndoor, 7.5 metre extension cable

Optional accessories

Cat. No Description

- 28889** Colour frame
- 28886** 4 leaf barndoor
- 28209** 7.5 metre ext. cable
- 28210** 15 metre ext. cable
- 28884** Scrim set
- 28880** Cone small
- 28881** Cone medium
- 28882** Cone large
- 25060** 6000/4000 W electronic ballast
- 25260** 6000 W magnetic ballast
- 28822** Flight case
- 28407** Mechanical dimmer
- 28883** Adaptor cable to other 6 KW ballasts

The Company reserves the right to make any variation in design or construction to the equipment described. © Strand Lighting Ltd 1998. Strand™, Strand Lighting™, Strand Quartzcolor™ are trade marks of Strand Lighting Limited and Strand Lighting Inc.

Strand Lighting Ltd North Hyde House Hayes Rd Heston Middx UB2 5NL UK Tel: +44 (0)181 571 3588 Fax: +44 (0)181 571 3305
 Strand Lighting GmbH Ullsteinstrasse 114-142 D-12109 Berlin Germany Tel: +49 (0) 30/70 79 51 0 Fax: +49 (0) 30/70 79 519 9
 Strand Lighting Italia srl Via delle Gardenie 33 00040 Pomezia-Roma Italy Tel: +39 06 91963.1 Fax: +39 06 9147136
 Strand Lighting Asia Ltd 7/F Corporation Square 8 Lam Lok Street Kowloon Bay Hong Kong Tel: +852 2757 3033 Fax: +852 2757 1767

LONDON - BERLIN - ROME - PARIS - MOSCOW - LOS ANGELES - NEW YORK - TORONTO - HONG KONG