

HMI 2.5 kW Daylight Fresnel

- Improved light quality and output, producing flatter and more even field
- High quality, rugged, durable
- Corrosion resistant
- IP23 factory rated for dry and humid conditions
- Compatibility of parts throughout the range
- A comprehensive range of accessories, interchangeable with existing Quartzcolor products
- Easy to service and maintain
- ON-OFF buttons, operated from both head and ballast
- Bonding eyes and rigging hooks
- Front and back focusing
- New focus system, easy to adapt from manual to pole operation and maintenance-free
- Quick release lamp holder
- Easy running barndoor ears
- Scratch resistant, black, non-reflective housing
- All heads supplied with barndoor, colour frame and head to ballast cable
- Meets all relevant international standards and regulations

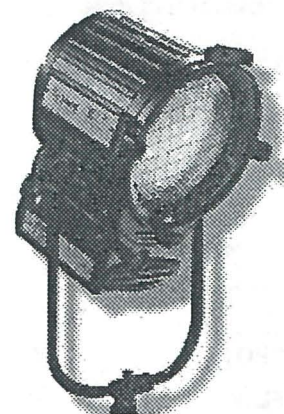

Operational data

Safety:

A microswitch system prevents the lamp operating if the front section is open.

25 x 25 mm wire mesh guard.

Accessory fitting:

Cast aluminium ears.
Spring loaded top and lower catch for retention of accessories.

Tilt adjustment:

Pivot located at centre of gravity for excellent balance and positive locking.

Focus adjustment:

Front and rear focusing knob for smooth and precise action from spot to flood positions

Lamp access:

Hinged lens door allows easy access for lamp replacement

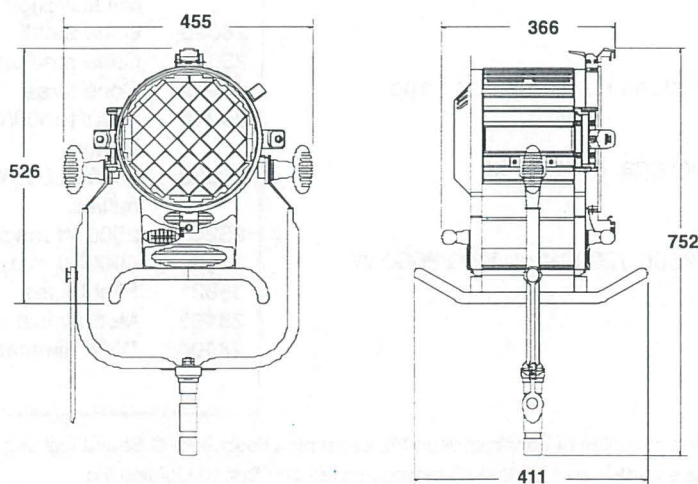

[mm]

Weights & dimensions

Lens diameter	250 mm SF	Weight (head+stirrup+skid)	13 kg
Accessory diameter	330 mm	Packed weight	22.5 kg
Filter cut size	320x320 mm	Packed volume	610x640x750 mm

Ballast dimensions

p/n 25040	270x235x380 mm	-13.5Kg
p/n 25050	270x235x380 mm	-15.6Kg
p/n 25240	380x355x170 mm	- 30 Kg
p/n 25250	488x388x635 mm	- 61 Kg

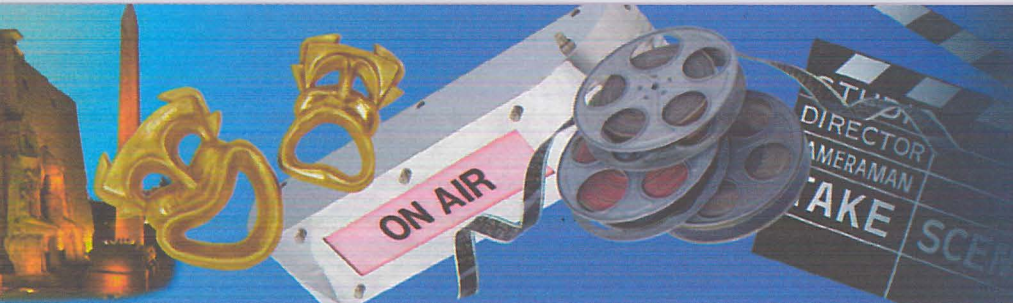

Photometric data

Typical performance based on 2500 W HMI lamp:

Throw [m]

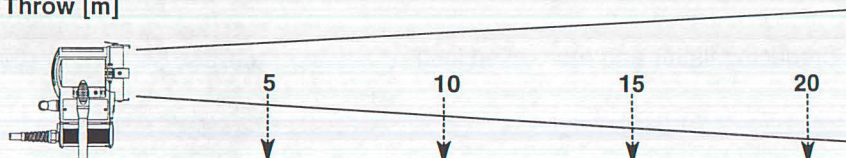

	Lux	φ [m]	Lux	φ [m]	Lux	φ [m]	Lux	φ [m]
SPOT (6°)	46,400	0.5	11,600	1	5,160	1.6	2900	2
FLOOD (54°)	5,280	5	1,320	10	590	15.3	330	20.4

Mechanical data

- Paint / Finish:** Powder coated epoxy paint with special extra high temperature treatment in critical areas.
External textured low gloss finish
- Lamp house:** Stainless steel with aluminium extrusions and die cast components
- Lamp holder:** High voltage with quick release pin clamping
- Mounting:** Robust tubular steel stirrup with standard EURO spigot

Environmental Data

- Max operating ambient temperature:** 45°C
- IP Rating:** IP 23
- Tilt recommended angle of use:** -60° / 0 / 60°

Electrical data

- Switching:** ON/OFF double pushbuttons from both head and ballast
- Ignitor:** Small, compact, high voltage, hot restrike
- Ignition voltage:** 50 kV
- Ballasts:** Electronic flicker-free, 2500/1200 W or 4000/2500 W
Magnetic 2500 W
- Standards compliance:** CE marking

Lamp data

- HMI/MSR 2500W single ended**
- LCL (mm):** 127
- Base:** G38
- Lumens:** 240,000
- Rated life hours (H):** 500
- Colour temp. (K):** 5600

Ordering information

Cat. No	Description
27909	HMI 2.5 kW bare head with stirrup
27060	HMI 2.5 kW supplied with stirrup, colour frame, 4 leaf rotating barndoor, 7.5 metre extension cable

Optional accessories

Cat. No	Description
28093	Colour frame
28114	4 leaf barndoor
28205	7.5 metre extension cable
28206	15 metre extension cable
28306	Scrim set (one double scrim, one single scrim, one half double scrim, one half single scrim)
28090	Cone small
28091	Cone medium
28092	Cone large
25040	2500/1200 W electronic ballast
25050	4000/2500 W electronic ballast
25240	2500 W magnetic ballast
25250	4000 W magnetic ballast
28821	Flight case
28403	Mechanical dimmer
28404	DMX dimmer

The Company reserves the right to make any variation in design or construction to the equipment described. © Strand Lighting Ltd 1998.
Strand™, Strand Lighting™, Strand Quartzcolor™ are trade marks of Strand Lighting Limited and Strand Lighting Inc.

Strand Lighting Ltd North Hyde House Hayes Rd Heston Middx UB2 5NL UK Tel: +44 (0)181 571 3588 Fax: +44 (0)181 571 3305
Strand Lighting GmbH Ullsteinstrasse 114-142 D-12109 Berlin Germany Tel: +49 (0) 30/70 79 51 0 Fax: +49 (0) 30/70 79 519 9
Strand Lighting Italia srl Via delle Gardenie 33 00040 Pomezia-Roma Italy Tel: +39 06 91963.1 Fax: +39 06 9147136
Strand Lighting Asia Ltd 7/F Corporation Square 8 Lam Lok Street Kowloon Bay Hong Kong Tel: +852 2757 3033 Fax: +852 2757 1767

LONDON - BERLIN - ROME - PARIS - MOSCOW - LOS ANGELES - NEW YORK - TORONTO - HONG KONG