

# FRESNELITE®

**3380**  
**STRAND CENTURY**

6" (152mm) 500/1000W

High intensity spotlight with  
variable soft edged beam  
and even field

- New lens and reflector design for maximum performance
- Accepts up to 1000W lamp for throws of up to 40'
- Lightweight extruded aluminum body
- Vented lens door for longer color life
- Spot to flood focus adjustment engineered for smooth operation
- Excellent barndooring characteristics
- All handles thermally insulated for cool operation
- Accessories include a new lightweight rotating barndoor and a safety clip for positive lock-in of barndoor and color frame

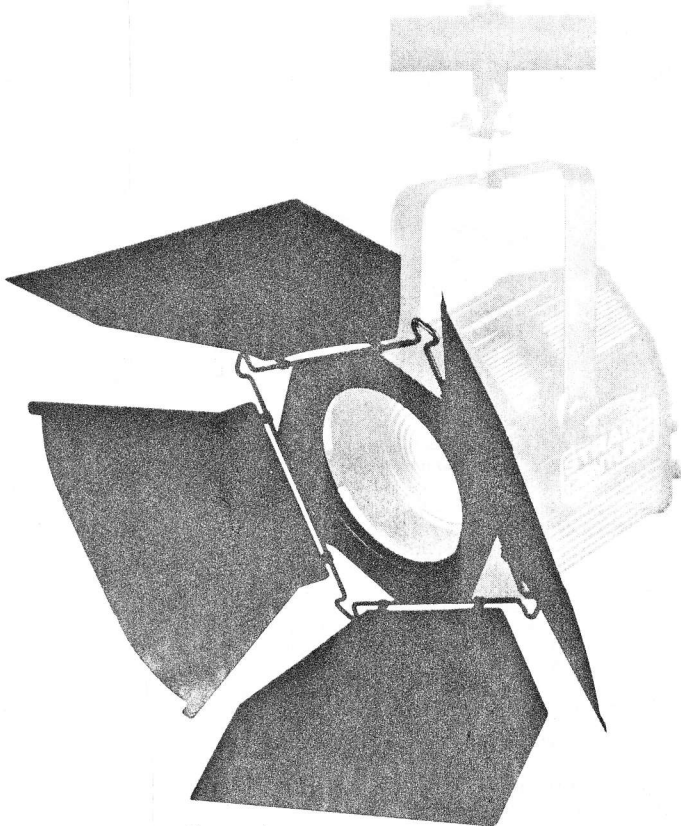

1406 8-Way Barndoor

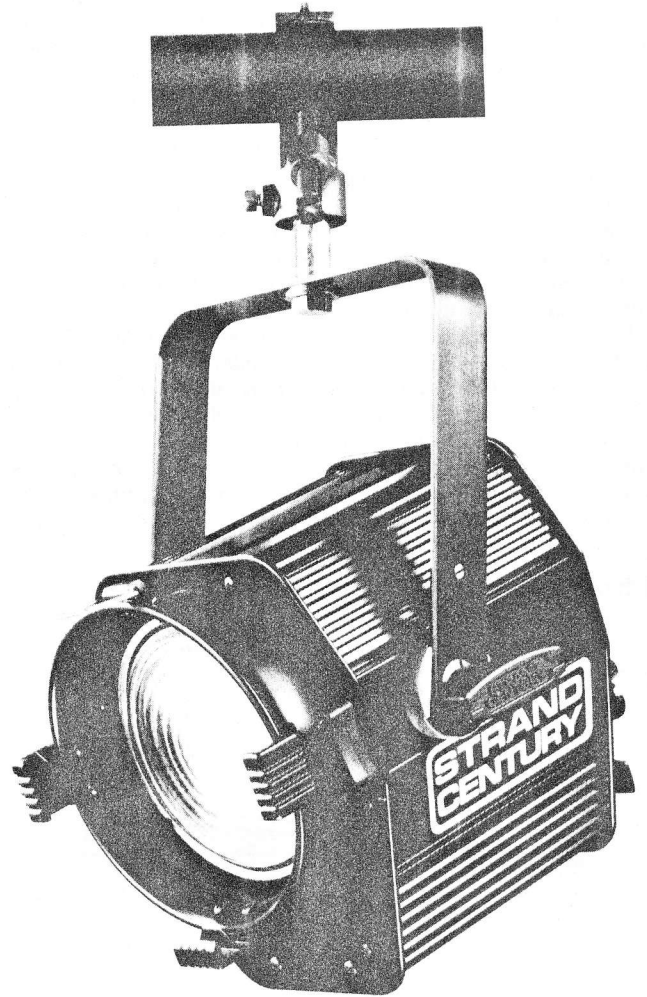

Cat. No.	Accessories
1108	Color or diffuser frame
1406	8-way barndoor
1332	High hat
1350	Accessory safety clip assembly
1500	Safety Cable



# Strand Century Fresnelite®

## 6" (152mm) 500/1000W

3380

### Specifications

This unit shall be a variable focus fresnel spotlight designed to accommodate tungsten-halogen or incandescent medium prefocus base lamps in 500, 750 and 1000 watt sizes. The housing shall be constructed of ribbed extruded aluminum sides between die formed steel cover plates. Lens door construction shall be of spun steel for strength and durability. Die cast aluminum accessory clips shall be screw retained to the lens door and shall be capable of holding a combination of a barndoor and three color frames and/or scrims.

Lamp and reflector access shall be through the side-hinged lens door. The door shall be secured with a spring-loaded stainless steel latch with a thermally insulated knob.

The 6" (152mm) fresnel lens shall be molded of high quality heat resistant borosilicate glass and retained by three molded plastic stand-off pieces. These stand-offs shall be designed to allow an air gap around the lens for additional ventilation of the lens and color media.

Flood to spot focusing shall be performed at the rear of the unit by means of a thermally insulated sweep arm. Focus position shall be indicated by a calibrated label.

Each unit shall be supplied with a malleable iron C-clamp to grip up to 2" (51mm) pipe, a steel yoke and 3' (0.9m) leads in fiberglass sleeving.

The unit shall have a 6° to 55° variable 1/2 peak angle and a 13° to 65° 1/10 peak angle and shall produce 194 footcandles at 30' (2160 lux at 9m) maximum (spot focus) and 46 footcandles at 20' (514 lux at 6m) maximum (flood focus) using a BTR lamp. Exterior finish shall be black baked enamel. Weight 10.5lb. (4.8kg). The entire unit shall be U.L. listed.

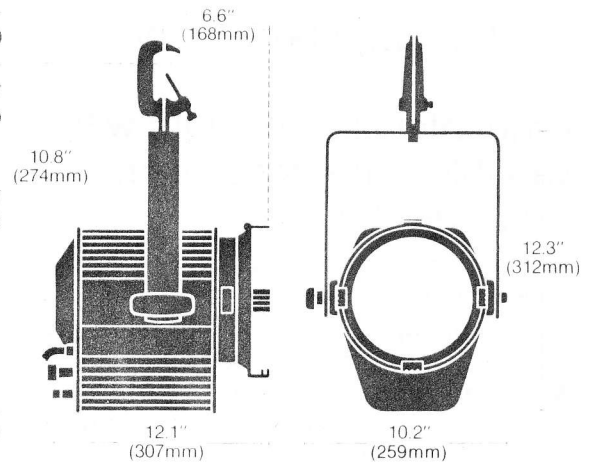

### Photometrics

#### SPOT FOCUS

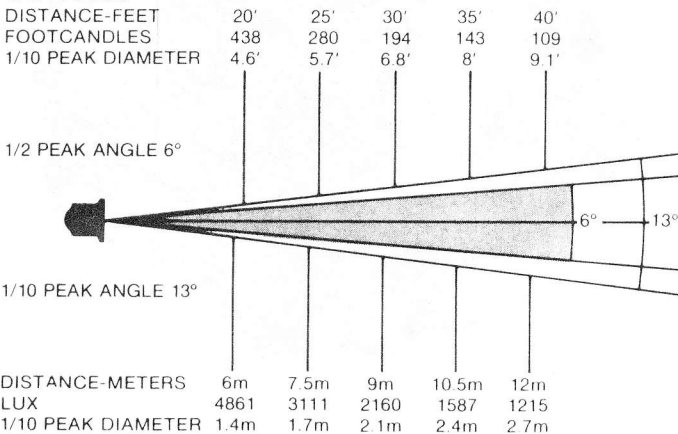

#### FLOOD FOCUS

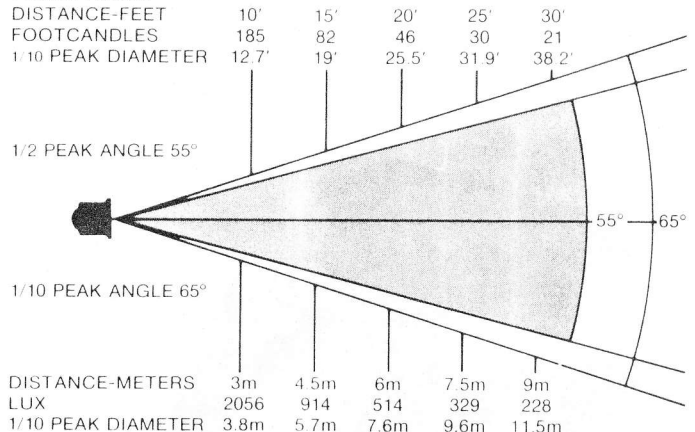

LAMP SHOWN: BTR 1000 WATT 200 HOUR 3200° K

OTHER LAMPS: MULTIPLY INTENSITY BY FACTOR GIVEN (MF)

MF	LAMP
.40	BTL 500 WATT 500 HOUR 3050° K
.47	BTM 500 WATT 100 HOUR 3200° K
.62	BTN 750 WATT 500 HOUR 3050° K
.73	BTP 750 WATT 200 HOUR 3200° K
.95	CP24 1000 WATT 200 HOUR 3200° K 220/240V

LAMP SHOWN: BTR 1000 WATT 200 HOUR 3200° K

OTHER LAMPS: MULTIPLY INTENSITY BY FACTOR GIVEN (MF)

MF	LAMP
.40	BTL 500 WATT 500 HOUR 3050° K
.47	BTM 500 WATT 100 HOUR 3200° K
.62	BTN 750 WATT 500 HOUR 3050° K
.73	BTP 750 WATT 200 HOUR 3200° K
.95	CP24 1000 WATT 200 HOUR 3200° K 220/240V

$$\text{FOOTCANDLES} = \frac{175,000}{\text{Distance}^2 (\text{Ft})} \quad \text{LUX} = \frac{175,000}{\text{Distance}^2 (\text{m})}$$

$$1/10 \text{ PEAK DIAMETER} = \text{Distance} \times .23$$

1/2 Peak Angle - where intensity drops to 50% of maximum

1/10 Peak Angle - where intensity drops to 10% of maximum

$$\text{FOOTCANDLES} = \frac{18,500}{\text{Distance}^2 (\text{Ft})} \quad \text{LUX} = \frac{18,500}{\text{Distance}^2 (\text{m})}$$

$$1/10 \text{ PEAK DIAMETER} = \text{Distance} \times 1.27$$

1/2 Peak Angle - where intensity drops to 50% of maximum

1/10 Peak Angle - where intensity drops to 10% of maximum

Representational graphics



# STRAND CENTURY

A Subsidiary of Rank America

Strand Century, Inc. 18111 South Santa Fe Ave., P.O. Box 9004, Rancho Dominguez, Calif. 90224 Tel: (213) 637-7500, Telex: 664741

Strand Century, Inc. 20 Bushes Lane, Elmwood Park, New Jersey 07407 Tel: (201) 791-7000, Telex: 130322

Strand Century Company, Ltd. 6490 Viscount Road, Mississauga, Ontario, Canada L4V1H3 Tel: (416) 677-7130, Telex: 06968646