

CD80 Digital Pack

User's Manual



Part Number: 40/B864
Issue: 4.0
Date: 1997-09-10

Offices And Service Centers

Phone numbers do not include country code or other international access data.

World Wide Web: <http://www.strandlight.com>

Asia: 7th Floor, Corporation Sq, 8 Lam Lok St, Kowloon Bay, Kowloon, Hong Kong
Tel: 757.3033 Fax: 757.1767

Canada: 2430 Lucknow Dr., Unit 15, Mississauga, ontario L5S 1V3 Canada
Tel: 905.677.7130 Fax: 905.677.6859

Italy: Via delle Gardenie 33 (Pontia Vecchia KM 33,400), 00040 Pomezia-Roma, Italy
Tel: 6914.7123 Fax: 6914.7136

U.K.: Mitchelson Industrial Estate, Oswald Road, Kircaldy, Fife, KY13Ly, Scotland
Tel: 159.265.2333 Fax: 159.265.3528

U.S.A.: 18111 South Santa Fe Ave., Rancho Dominguez, CA 90221 USA
Tel: 310.637.7500 Fax: 310.632.5519

US Service & Support 800 4 STRAND (800.478.7263)

The material in this manual is for information purposes only and is subject to change without notice. Strand Lighting assumes no responsibility for any errors or omissions which may appear in this manual. For comments and suggestions regarding corrections and/or updates to this manual, please contact your nearest Strand Lighting office.

El contenido de este manual es solamente para información y está sujeto a cambios sin previo aviso. Strand Lighting no asume responsabilidad por errores o omisiones que puedan aparecer. Cualquier comentario, sugerencia o corrección con respecto a este manual, favor de dirigirlo a la oficina de Strand Lighting más cercana.

Der Inhalt dieses Handbuchs ist nur für Informationszwecke gedacht, Aenderungen sind vorbehalten. Strand Lighting uebernimmt keine Verantwortung für Fehler oder Irrtuemer, die in diesem Handbuch auftreten. Für Bemerkungen und Verbesserungsvorschlaege oder Vorschlaege in Bezug auf Korrekturen und/oder Aktualisierungen in diesem Handbuch, moechten wir Sie bitten, Kontakt mit der naechsten Strand Lighting-Niederlassung aufzunehmen.

Le matériel décrit dans ce manuel est pour information seulement et est sujet à changements sans préavis. La compagnie Strand Lighting n'assume aucune responsabilité sur toute erreur ou omission inscrite dans ce manuel. Pour tous commentaires ou suggestions concernant des corrections et/ou les mises à jour de ce manuel, veuillez s'll vous plait contacter le bureau de Strand Lighting le plus proche.

Copyright 1997, Strand Lighting Limited. All rights reserved.

Information contained in this document may not be duplicated in full or in part by any person without prior written approval of Strand Lighting. Its sole purpose is to provide the user with detailed operational information for the equipment supplied. The use of this document for all other purposes is specifically prohibited. Certain features of the equipment described in this document may form the subject of patents or patent applications.



Danger

This equipment is designed to operate from the mains electricity supply and contains voltages which, if touched, may cause death or injury. It should only be operated in accordance with these instructions and for the purpose of a lighting control system.

Table of Contents

Introduction and Assistance	1
Manual Organization.....	1
Definitions.....	2
Conventions.....	3
Technical Assistance.....	3
Problems	3
Questions	3
Spare Parts	3
Comments and Suggestions	3
World Wide Web.....	3
Addresses	3
Operational Features	5
Protocol	5
Configuration	5
Analog Input.....	6
Dimming Characteristics.....	6
Regulation	6
Output	6
Efficiency	6
Protection	7
Dimmer Level Retention.....	7
Servicing	7
Hardware Description	9
Chassis	10
Digital Controller.....	11
Control Module Front Panel	11
Controller Electronics	12
Power Control and Cooling Assemblies	12
Dimmer Types.....	13
Input Power Connectors.....	14

Installation	15
Preparation	15
Environmental Considerations.....	15
Power Requirements	15
Three Phase Power Requirements	15
Single Phase Power Requirements	15
Plan Pack Positioning	16
Plan Wiring Layout.....	17
Installation.....	17
Install Packs	17
Set Correct Phasing.....	18
Set for Single Phase Operation.....	18
Set for Three Phase Operation (default).....	18
Connect Power.....	19
Connect Load Wires	21
Connect Control Wires	22
AMX192 Control Wiring	22
DMX512 Dimmer Control Wiring	23
Setup.....	24
Dimmer Signal Number	24
Combining Pack Types	24
Dimmer Number Offset	25
Set 6Kw/12Kw Control Mode	26
Use Every Control Signal (default)	26
Use Every Other Control Signal	27
Set Dimmer Curve	27
Modified Square Law Curve (default).....	27
Analog Pack Matching Curve.....	27
Using AMX192 Dimmer Control	28
Using DMX512 Dimmer Control	29
Discreet Analog Control Hookup.....	30
Set Analog Pile-on Mode.....	31
Analog Plus Protocol	31
Highest Takes Precedence (default)	31
Set Analog Input Level	31
Zero to +10VDC (default).....	31
Zero to +15VDC	31
Set "Status Quo"	32
"Status Quo" OFF (default)	32
"Status Quo" ON.....	32
Fault Protection	32
Hot Pocket.....	33
Local Dimmer Control	33
Dimmer Panic	33
ON/NORMAL Pushbuttons.....	33
Mode Switch Settings	34
Retrofitting an Analog Pack.....	34

Basic Troubleshooting	35
Component Removal.....	35
Controller Replacement	35
Removing the Controller	36
Installing the Controller.....	36
SSR Replacement.....	36
Replacing a dual 1.2Kw or 2.4Kw SSR	36
Replacing a single 2.4Kw or 6Kw SSR.....	36
Replacing a 12Kw SSR	37
Changing other components	37
Problems Affecting the Entire Pack.....	37
Problems Confined to a Single Phase	38
Individual Dimmer Problems.....	39
 Periodic Maintenance	 45
 Index.....	 47

Table of Figures

Figure 1. CD80 Digital Pack	9
Figure 2. CD80 Digital Pack Controller.....	11
Figure 3. CD80 Digital Pack Wall Mounting.....	16
Figure 4. 24 Dimmer Pack Power Connection	19
Figure 5. 12 Dimmer 2.4Kw Pack Power Connection	19
Figure 6. 6 Kw Pack Power Connection	20
Figure 7. 12Kw Pack Power Connection	20
Figure 8. 73230 Pack Power Connection	21
Figure 9. XLR to TA4 Series Adapter	22
Figure 10. AMX192 Extension Cable.....	23
Figure 11. DMX512 Dimmer Control Extension Cable	23
Figure 12. Dimmer Curve Jumper Location.....	27
Figure 13. Connect Packs for AMX192.....	28
Figure 14. Connect Packs for DMX512.....	29
Figure 15. Digital Dimmer Controller Removal	35
Figure 16. 24 Dimmer Digital Pack Parts	40
Figure 17. 12 Dimmer 2.4Kw Digital Pack Parts.....	41
Figure 18. 6Kw Digital Pack Parts.....	42
Figure 19. 12Kw Digital Pack Parts.....	43

Table of Tables

Table 1. AMX192 Control Inputs	22
Table 2. DMX512 Control Inputs	23
Table 3. Discreet Analog Input Connections	30
Table 4. Mode Switch Settings	34
Table 5. Repair Parts for 24 Dimmer Digital Pack	40
Table 6. Repair Parts for 12 Dimmer 2.4Kw Digital Pack	41
Table 7. Repair Parts for 6.0Kw Digital Pack.....	42
Table 8. Repair Parts for 12Kw Digital Pack.....	43

Introduction and Assistance

This manual provides information on the operating procedures for the CD80 Digital Dimmer Pack.

Manual Organization

This manual contains the chapters shown below, plus an Index.

Introduction and Assistance starting on page 1 tells you about the organization of this manual, plus definitions and conventions used. Also tells you how to get technical help if necessary

Operational Features starting on page 5 gives an overview of the operational features of CD80 Digital Packs.

Hardware Description starting on page 9 gives an overview of the hardware and how it works together.

Installation starting on page 15 tells you about the installation requirements for CD80 Digital Packs and peripherals. This chapter shows pinouts for externally accessible connectors, cable types and lengths, and (where applicable) setup information.

Basic Troubleshooting starting on page 35 tells you how to begin troubleshooting if you have problems with a pack. Since actual internal repair of the pack electronics is beyond the scope of this manual, this chapter shows only the basic steps you can take without having to replace individual circuit parts, and before you call for help from Strand Lighting.

Periodic Maintenance starting on page 45 lists the steps which should be taken to keep your Digital Packs running at their best.

Definitions

This manual uses the following definitions throughout:

- Circuit** Connection device and wiring for powering a lighting fixture from a dimmer.
- Dimmer** Device controlling power to a lighting fixture. Two lights on the same dimmer cannot be separately controlled.
- Channel** Device controlling a dimmer or group of dimmers. Historically, there is a physical controller (such as a slider) for each channel. On most current control systems, channels are numbers accessed by a numeric keypad. Each channel can control multiple dimmers.
- Patch** Historically, the process of physically connecting circuits to dimmers. Now usually refers to electronic assignment of dimmers to channels. "Patch" does not refer to assignment of channels to cues or submasters.
- Preset** A predefined setup of intensities for a set of channels, stored in memory for later replay.
- Memory** Storage location for preset information.
- Cue** The process of recalling a preset from its memory location and putting the result on stage.
- Preset, Memory, and Cue are often used interchangeably.*
- Submaster** A controller (usually a linear slider controller) which allows manual control of groups, effects, cues, or channels.
- Fade** A gradual change in stage levels from one set of intensities ("look") to another.
- Up-fade** The portion of a fade which involves only channels which are increasing in level.
- Down-fade** The portion of a fade which involves only channels which are decreasing in level.
- Crossfade** A fade which contains both an up-fade and a down-fade. Also may refer to any fade where the levels of one cue are replaced by the levels of another cue.
- Bump** An instantaneous change in stage levels from one set of intensities ("look") to another.

Conventions

The following conventions are used in this manual:

- ON (all capital text) shows to the status of a function or switch, as in "Turn the switch ON."
- Live (text with first letter capitalized) shows the name of a function or mode of operation, as in Live mode, Group function, or Preview display.

Technical Assistance

CD80 Digital Dimmer Packs require a minimum of maintenance and servicing.

Problems If equipment fails to operate properly upon installation, or under normal load and temperature conditions, and basic troubleshooting procedures are not effective, please contact your nearest Strand Authorized Service Center or Strand Lighting Field Service at the office serving your area.

Questions For technical questions regarding setup, operation, or maintenance of this equipment, please contact your nearest Strand Authorized Service Center or the Strand Lighting Field Service office serving your area.

Spare Parts For purchase of upgrades, accessories, peripherals or documentation, please contact your nearest Strand Authorized Service Center or the Strand Lighting office serving your area.

Comments and Suggestions For comments regarding equipment functions and possible improvements, or for comments on this manual, please write to the Strand Lighting office serving your area.

World Wide Web You can access the Strand Lighting World Wide Web site at <http://www.strandlight.com>.

Addresses Addresses for all of the Strand Lighting offices are shown at the front of this manual.

Commission
The Secretary of State
of the State of New York

Department of State
120 South Street
Albany, New York 12242-1200
Telephone: (518) 474-8000
Fax: (518) 474-8001

Internet: <http://www.state.ny.us>
E-mail: info@state.ny.us

For more information, please contact:
New York State Office of General Services
100 State Street
Albany, New York 12242-1000
Telephone: (518) 474-8000

For more information, please contact:
New York State Office of Information Services
100 State Street
Albany, New York 12242-1000
Telephone: (518) 474-8000

For more information, please contact:
New York State Office of Information Services
100 State Street
Albany, New York 12242-1000
Telephone: (518) 474-8000

For more information, please contact:
New York State Office of Information Services
100 State Street
Albany, New York 12242-1000
Telephone: (518) 474-8000

For more information, please contact:
New York State Office of Information Services
100 State Street
Albany, New York 12242-1000
Telephone: (518) 474-8000

Operational Features

This chapter presents the basic operational features of the CD80 Digital Pack.

Protocol

The CD80 Digital Pack Controller will accept and decode AMX192 multiplexed analog signals or DMX512 digital dimmer protocols.

- Protocol type is sensed automatically by the Controller
- Separate analog and digital protocol input connectors allow you to hook analog and digital control to each pack simultaneously if required.

Caution



If the controller senses more than one protocol hooked up and active it will lock onto the first protocol it sees, and stick with that protocol until the protocol disappears. When a Digital Pack Controller is first powered up it will scan the AMX192 port first, and then the digital port. If signals are present on both, the AMX192 signal will take priority.

Configuration

One CD80 Digital Pack contains 24 1.2Kw dimmers, twelve 2.4Kw dimmers, or six 6Kw or 12Kw dimmers.

- The controller can be set to start "reading" dimmer levels at any dimmer number required (1-192 for AMX192 and 1-512 for DMX512 signals). This provides maximum flexibility in using CD80 Digital Dimmer Packs with multiple consoles and/or other types of packs or dimmers.
- The 12 channel controller can be set to read 12 consecutive control signals and control either 12 or 6 consecutive dimmers, or to read every other signal of 12 to control 6 consecutive dimmers. The second option is used for systems where the 6Kw/12Kw assignments will be handled by the console patch.

Analog Input

The CD80 Digital Pack Controller can input 12 (Cat. #8216) or 24 (Cat. #8215) discreet analog signals in addition to the signal from the main console. This is an easy way to set up manual house lights, or set up a minimum dimmer level for some of the dimmers.

- The controller can read 0-10VDC or 0-15VDC analog signals.
- Analog input processing can be set for standard pile-on operation or so that the dimmer level is the discreet analog input level plus the protocol input level (up to a maximum of 100%).
- 12 (Cat. #8216) or 24 (Cat. #8215) ON/NORMAL (override) pushbutton switches let you turn any dimmer ON without a console or discreet analog signal, or override the console and discreet analog inputs.

Dimming Characteristics

Regulation Each 120VAC dimmer module, with circuitry in the Digital Controller module, regulates output voltage with changes in the AC line from 108 to 130 volts RMS.

Dimmers will maintain output RMS voltage within $\pm 2\%$ with changes in load from 10 watts to full rated load at any point on the dimming curve (30 watts to full rated load for 12Kw Packs).

- Output**
- Output RMS voltage versus setting follows a modified square law dimming curve.
 - Output waveform is a variable conduction angle 120VAC sine wave.
 - Output waveform rise time is greater than 500 microseconds.
 - Output response time (from control signal change) is less than 0.1 seconds.
 - Output connections can be Grounded Twist Lock, Pin Plug, U-Ground (up to 2.4Kw packs only), Multipin (1.2Kw and 2.4Kw packs only), or terminal strip outputs.

Efficiency The power efficiency of the dimmer is a minimum of 95% at full load.

Protection

- Front panel overtemperature indication. The OverTemp thermostat will turn OFF all dimmers in the pack when the temperature on the pack heat sink is greater than 85°C.
- Solid State Relay Peak Surge Rating:
 - ◆ 2.4Kw Pack - 600 Amps.
 - ◆ 6Kw Pack - 1000 Amps.
 - ◆ 12Kw Pack - 1000 Amps.
- Short Circuit Protection:
 - ◆ 2.4Kw - Fully Magnetic breakers protect against shorts across 40 feet of #14 AWG cable. Short circuit proof version withstands shorts at output plug (lifetime 100 surges).
 - ◆ 6Kw Pack - Fully magnetic breakers protect against shorts across 125 feet of #8 AWG cable (lifetime 100 surges).
 - ◆ 12Kw Pack - Fully magnetic breakers protect against shorts across 125 feet of #8 AWG cable (lifetime 100 surges).

Dimmer Level Retention

The microprocessor will maintain current dimmer levels ("Status Quo" memory) for 30 minutes if there is a loss of control signal (i.e., when you turn the console OFF). This feature can be turned OFF if required.

Servicing

The CD80 Digital Pack is designed to be easily serviced in the field. It incorporates:

- Rapidly replaceable Controller module.
- Rapidly replaceable SSR modules.



Hardware Description

The CD80 Digital Pack is a lightweight portable performance dimming pack containing six (6Kw and 12Kw pack), twelve (2.4Kw pack), or 24 (1.2Kw and 2.4Kw pack) dimmers.

- Size - 23.25" x 20.00" x 7.75"
- Weight - 65 pounds
- 125" aluminum alloy housing.
- Gray semi-gloss power coat finish with blue and white silk-screened graphics.
- Integral carrying handles for transporting.
- Optional wall mounting.

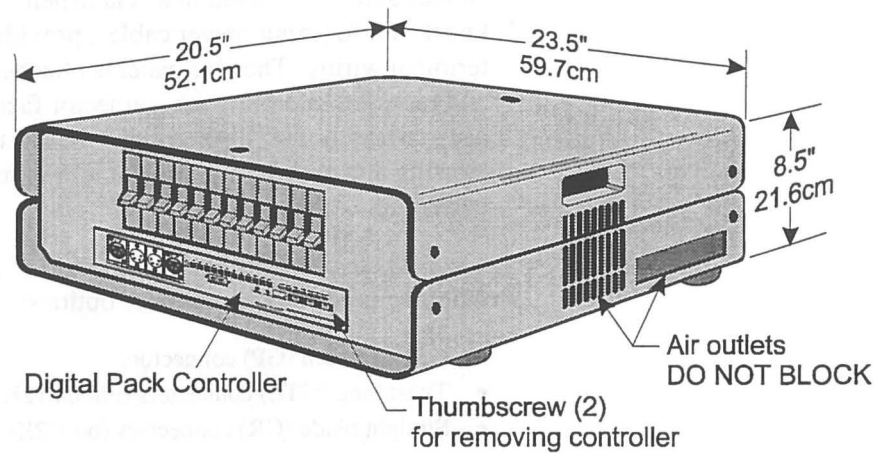

Front view

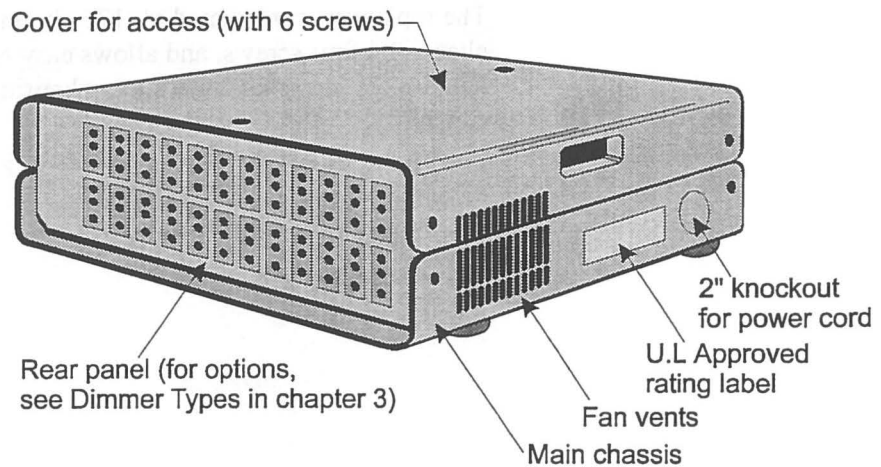

Rear view

Figure 1. CD80 Digital Pack

Chassis

The CD80 Digital Pack chassis consists of a main structural chassis (bottom housing and front panel), a removable top, and an interchangeable rear connector panel. The heavy gauge structural panels create a rugged container even though assembled with only four pieces.

The main structural chassis consists of the bottom housing and front panel fastened rigidly together. The front panel is recessed to protect the breakers and PCB face panel components.

The front panel, constructed of .090 thick aluminum alloy, contains UL listed circuit breakers and a slot for the plug in printed circuit board module.

The bottom housing, constructed of .125 thick aluminum alloy, supports a heat sink subassembly (mounting the solid state relays and an overheat thermostat), a fan, a fan guard, a torroidal choke subassembly (with chokes solidly mounted in a "clamshell" Lexan retaining channel), and a knock-out for input power cables, provided for customer removal for terminal wiring. The rear panel is attached to the main structural chassis and recessed to protect the connector faces. Four large diameter feet, approximately 3/4" high, are attached to the underside of the bottom housing and existing feet mount holes are accessible for easy wall mounting.

The rear connector panel, constructed of .090 thick aluminum alloy, is manufactured in four customer options:

- Grounded pin (GP) connectors.
- Twist lock (GTL) connectors (not on 12Kw units).
- Straight blade (GR) connectors (on 1.2Kw and 2.4Kw only).
- A terminal block (TB) for hard wiring of outputs plus control.

The top cover, constructed of .125 aluminum alloy, fastens to the main chassis by four screws, and allows easy access for servicing. Recessed handles are integrated into the top housing for easy one man carry capability.

Digital Controller

The plug in controller, accessible on the front panel of the CD80 Digital Pack, is made of a face plate and control card. The CD80 Digital Pack Controller contains all necessary indicators and control electronics, allowing rapid interchange of active components in the field without the need for calibration or adjustment.

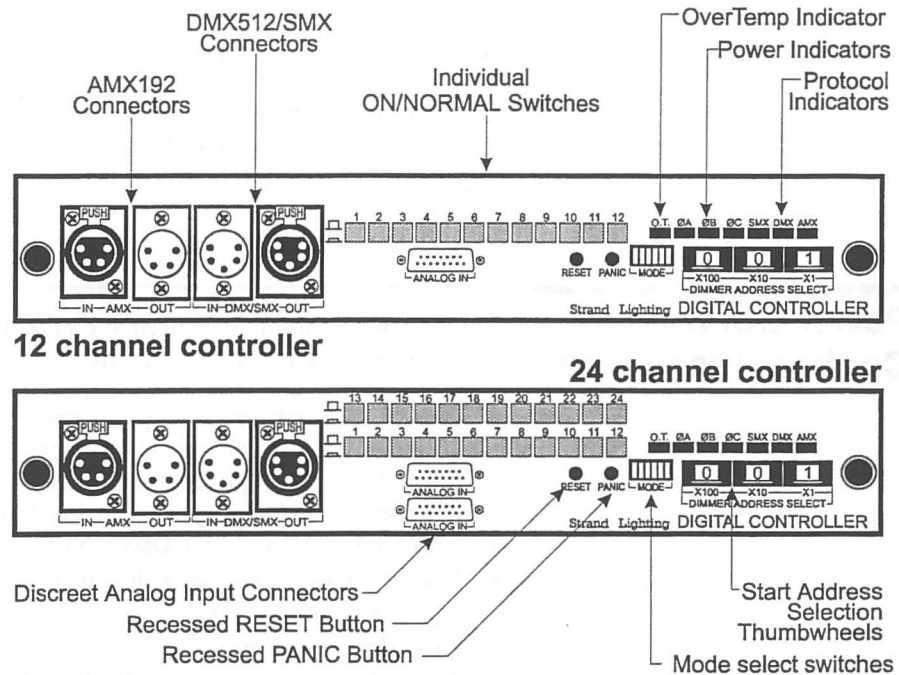

Figure 2. CD80 Digital Pack Controller

Control Module Front Panel

The following functions and indicators are on the Control Module face plate:

- Three Power Indicators (green) - show when each power phase is present.
- Three Protocol Indicators (yellow) - show which input protocol is currently being decoded.
- A 6 position Mode Select DIP switch for selecting various parameters.
- OverTemp Indicator (red) - On when heat sink temperatures exceed +85°C. The pack will shut down when this function is activated.
- Input and output connectors for analog (AMX192) and digital (DMX512) multiplexed inputs.
- Input connector(s) for up to 12 or 24 discreet analog control signals.
- A set of three thumbwheel switches for selecting the start dimmer number for the pack.
- An alternate action "Panic" switch - to turn all dimmers ON full. Push this switch again to return all dimmers to normal operation.
- A "Reset" switch - to restart the processor if required.
- 12 or 24 alternate action ON/NORMAL (override) pushbutton switches let you turn any dimmer ON without a console or discreet analog signal, or override the console and discreet analog inputs. These switches are backlit to show the approximate level of the associated dimmer.

Controller Electronics

The CD80 Digital Pack Controller will accept and decode AMX192 multiplexed analog signals or DMX512 digital dimmer protocols. An additional connector (2 connectors on 24 channel units) allows inputting discreet analog signals if requires.

The Controller electronics contains all of the electronics required to detect input signal type, decode the incoming signal, and produce 24 phase synchronized pulse width modulated control signals to drive the SSRs.

The electronics are powered from a power supply connected to the phase A power source. The phase B and phase C power sources are used for phase reference only.

Power Control and Cooling Assemblies

The following circuit and thermal elements in the bottom housing and front panel serve to control and dissipate power in the CD80 Digital Pack:

- One SSR for each dimmer, rated appropriately for the dimmer power rating, are mounted on a common 18" long heat sink anchored to the bottom housing. Each SSR is field replaceable and identical to SSRs in Strand Lighting CD80 Dimmer Racks. 12Kw packs use a dual SSR block, which is different from the single SSR block used in CD80 dimmer racks.
- One torroidal choke for each dimmer is mounted in a common assembly adjacent to the heat sink.
- One primary, fully magnetic circuit breaker for each dimmer is mounted to the front panel and provides for protection of individual dimmers.
- A fan mounted on the positive pressure side of the heat sink provides approximately 105 CFM (derated) of cooling air through the enclosure.
- A phase changing/terminal block assembly on the bottom housing (except 12Kw packs) provides termination of 3 phase 4-wire plus ground 120/208VAC, or single phase 3-wire plus ground 120/240VAC. 3-phase ratings are 80 amps for 1.2Kw and 2.4Kw packs, and 100 amps for 6Kw packs. Single phase ratings are 120 amps for 1.2Kw and 2.4Kw packs, and 150 amps for 6Kw packs.

Dimmer Types

Dimmer modules are available in the following 120VAC configurations. These dimmers are intended for use with incandescent and inductive loads only, and are UL listed and cUL listed.

Part #	Dimmers		Ckt Bkrs	Output Conn.		Power Input
	#	Cap		#	Type	
73200 (was 8324)	24	1.2Kw	15A	20	20A GTL	200A TB
73201 (was 8326)	24	1.2Kw	15A	24	20A GP	200A TB
73202 (was 8326)	24	1.2Kw	15A	24	20A GR	200A TB
73203 (was 8526C)	24	1.2Kw	10A	24	15A GR	200A TB
73204 (was 8327)	24	1.2Kw	15A	24	20A TB	200A TB
73207	24	1.2Kw	15A	4	20A Multi*	400A Cam-Lok
73213 (was 8526C)	12	1.8Kw	15A	24	15A GR	200A TB
73205 (was 8528)	12	2.4Kw	20A	24 2	20A GP & 20A Multi*	200A TB
73206 (was 8529)	12	2.4Kw	20A	24 2	20A GTL & 20A Multi*	200A TB
73210 (was 8524)	12	2.4Kw	20A	24	20A GTL	200A TB
73211 (was 8525)	12	2.4Kw	20A	24	20A GP	200A TB
73212 (was 8526)	12	2.4Kw	20A	24	20A GR	200A TB
73214 (was 8527)	12	2.4Kw	20A	24	30A TB	200A TB
73240	24	2.4Kw	20A	24	20A GTL	300A TB
73241	24	2.4Kw	20A	24	20A GP	300A TB
73244	24	2.4Kw	20A	24	20A TB	300A TB
73247	24	2.4Kw	20A	4	20A Multi*	400A Cam-Lok
73220 (was 8566)	6	6.0Kw	50A	12	60A GTL	300A TB
73221 (was 8567)	6	6.0Kw	50A	12	60A GP	300A TB
73224 (was 8568)	6	6.0Kw	50A	12	60A TB	300A TB
73227	6	6.0Kw	50A	12	60A GP	400A Cam-Lok
73230 (was 8563)	6	12Kw	100A	12	100A GP	400A Cam-Lok
73234 (was 8564)	6	12Kw	100A	12	100A TB	300A TB

* Socapex compatible

Caution



These dimmer packs are designed and rated for use with incandescent or inductive loads only. Dimmer packs may be damaged if used with any other type of loads.

The following controllers are available for retrofitting CD80 Packs and for spares:

- 8215 - 24 channel Digital Pack Controller (for 1.2Kw and 2.4Kw packs)
- 8216 - 12 channel Digital Pack Controller and retrofit kit (for 2.4Kw, 6Kw, and 12Kw packs).

The 24 channel Digital Pack Controller cannot be retrofitted into any 12 channel CD80 Packs. Cat. #8215 contains only a 24 channel Digital Pack Controller. The 12 channel Digital Pack Controller is a direct replacement for the Multiplexed Analog Pack Controller (part #3-258358-010) and the Discreet Analog Pack Controller (part #3-258362-010). Cat. #8216 contains a 12 channel Digital Pack Controller and the necessary items for retrofitting older CD80 packs.

Input Power Connectors

A variety of input power connectors can be custom mounted in the CD80 Digital Pack if required. Packs using special input connectors may not carry UL or cUL listing. Please contact your sales representative for details.

Installation

Preparation

Before installing your CD80 Digital Pack(s), you should carefully consider the environment in which the equipment is to be installed, the power feeding the equipment, and the required conduit and/or cable runs.

Environmental Considerations

To maximize equipment life, and minimize the chance of failures, the following environmental requirements should be met:

- Temperature -- 40°C (104°F).
- Humidity -- 5%-80% relative humidity maximum, no condensation.

Caution



Dimmer pack efficiency is at least 95%. Since the remainder of the energy is dissipated as heat, they should be installed in a room with adequate ventilation to dissipate a heat load equivalent to 5% of the maximum load the dimmer racks will handle.

Power Requirements

1.2Kw, 2.4Kw, and 6Kw CD80 Digital Dimmer Packs can be powered by three phase or single phase power. 12Kw Digital Dimmer packs must be powered by three phase power.

Three Phase Power Requirements

- 1.2Kw or 2.4Kw Pack - 120/208VAC, 80 Amps, 4-wire plus ground
- 6Kw Pack - 120/208VAC, 100 Amps 4-wire plus ground
- 12Kw Pack - 120/208VAC, 200 Amps, 4-wire plus ground

Single Phase Power Requirements

- 1.2Kw or 2.4Kw Pack - 120VAC, 120 Amps, 3-wire plus ground
- 6Kw Pack - 120VAC, 150 Amps 3-wire plus ground
- 12Kw Pack - Single phase operation is not allowed.

Warning



Do not install this equipment with power applied. Make sure that your incoming power is disconnected before proceeding.

Do not provide 220VAC power to a 120VAC pack, as damage may result.

Plan Pack Positioning

CD80 Digital Packs may be placed on any flat surface for normal operation. You may stack up to 8 units vertically. Do not place more than 2 units side to side unless there is at least 24 inches between packs. Otherwise, the hot air exhaust from each unit will simply feed into the next. In permanent or semi-permanent installations, you can build shelves to hold packs or mount them on a wall separated by at least 24 inches horizontally. Vertical shelf spacing should allow removal of the CD80 Digital Pack top covers for access to SSR modules if required. To mount the packs on a wall, remove the rubber feet and use their mounting holes. Figure 3 shows dimensions for these mounting holes.

Warning



*This equipment is intended for indoor use only.
Utilizer dans endroit a l'abri.*

*For CSA approval when mounting over a combustible surface, a floor plate of at least 1.44mm galvanized or 1.6mm uncoated steel extended at least 150mm beyond the equipment on all sides must be installed.
Lorsque l'appareil est installé sur ou au-dessus d'une surface combustible, on doit prévoir une plaque d'acier galvanisée d'au moins 1.44mm ou une plaque d'acier sans revêtement de 1.6mm se prolongeant sur au moins 150mm tout autour de l'appareil.*

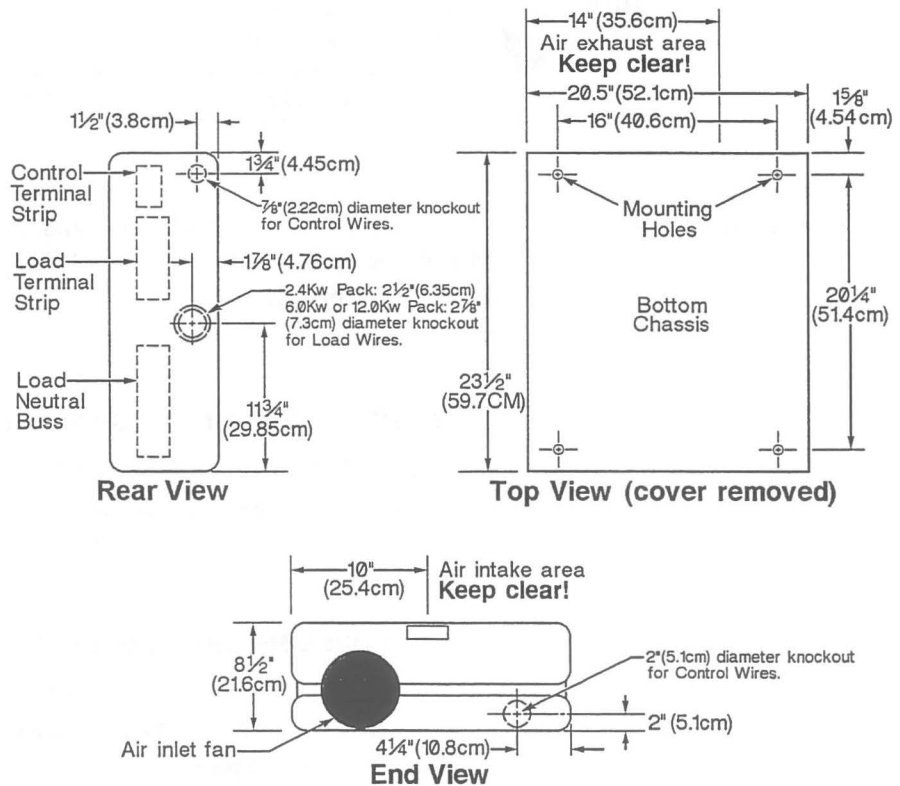

Knockout positions differ for 12Kw packs. Please check size and spacing before installing conduit.

Figure 3. CD80 Digital Pack Wall Mounting

Plan Wiring Layout When installing packs with terminal strip wiring, the location of conduit runs and their entrance to the pack is important and should be carefully planned before cutting holes or attaching conduit. Figure 3 shows the allowed entry areas for the various types of wiring. When installing portable packs, all connections are external.

When you are planning a hookup for a portable system you should avoid running control and load wires parallel to each other. The radio frequency noise produced by the load wiring may cause disruption to the control signal.

Caution



Do not run power feed or load wires in the same conduit or wireway as control wiring.

Do not run wiring from other unrelated equipment in the same conduit with CD80 wiring.

Do not run wiring in ways other than shown on system riser diagram. CD80 systems are designed to be installed in a specific manner.

Do not substitute plastic conduit for metal where conduit is called for. Metal conduit acts as a ground and shield.

Do not substitute shielded wiring for unshielded wiring or conduit. Changes in transmission line capacitance can cause problems with the control signals.

Installation

Once you have determined that all required conditions for the installation will be met, you can install the packs.

Install Packs Install the dimmer packs and run conduit as required.

1. Unpack the packs.
2. Make sure that any conduit work which will be covered up is completed.
3. Set or fasten packs in place as planned. If you are mounting packs on the wall, make sure that the fan is at the bottom of the unit as mounted.
4. Cut required conduit holes and install conduit.
5. Vacuum out any metal chips resulting from making conduit holes.

Set Correct Phasing

Mode Switch 2 sets the type of power the Control Module will be expecting. You must set this switch **and** the phase selector plug inside the pack to the same phase type. The factory default setting for Mode Switch 2 and the phase selector plug is 3-phase.

The phase changing terminal assembly (consisting of a terminal block and a connector pair assembly) provides termination for a 3-phase 4-wire 240/208VAC 80 AMP power source or a single phase 3-wire 120/240VAC 120 AMP power source in 2.4Kw and 6Kw CD80 Digital Packs.

Set for Single Phase Operation

1. Make sure power to the pack is OFF and take the top cover OFF.
2. Plug the phase connector into the single phase side of the phase receptacle.
3. Set Mode Switch 2 to ON (push in at the top of the switch).
4. Replace the top cover unless you still need to connect power.

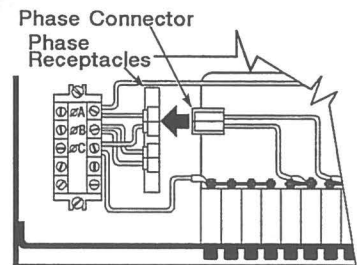

Set phase connector
Pack top view (opened)

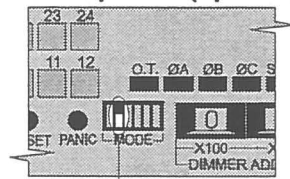

Set Mode switch 2 ON
(push in at top)
Controller front panel

Set for Three Phase Operation (default)

1. Make sure power to the pack is OFF and take the top cover OFF.
2. Plug the phase connector into the three phase side of the phase receptacle.
3. Set Mode Switch 2 to OFF (push in at the bottom of the switch).
4. Replace the top cover unless you still need to connect power.

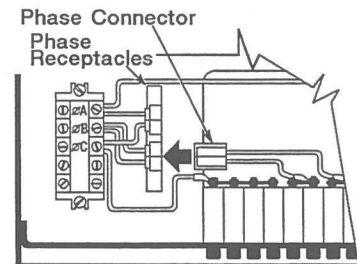

Set phase connector
Pack top view (opened)

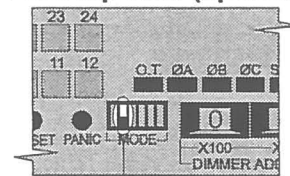

Set Mode switch 2 OFF
(push in at bottom)
Controller front panel

12Kw Packs are always operated with three phase power. Make sure that the Mode Switch 2 is set to OFF for any 12Kw packs. There is no phase change plug inside a 12Kw Pack.

Connect Power Connect power to the pack by attaching your power leads to the power terminal block inside the pack. For portable packs, close the pack up after connecting power. For terminal strip packs, leave the top open to connect load wires.

The only components that do not come installed in the pack are the neutral bus bar set screws. They are in a plastic bag attached to the neutral bus bar.

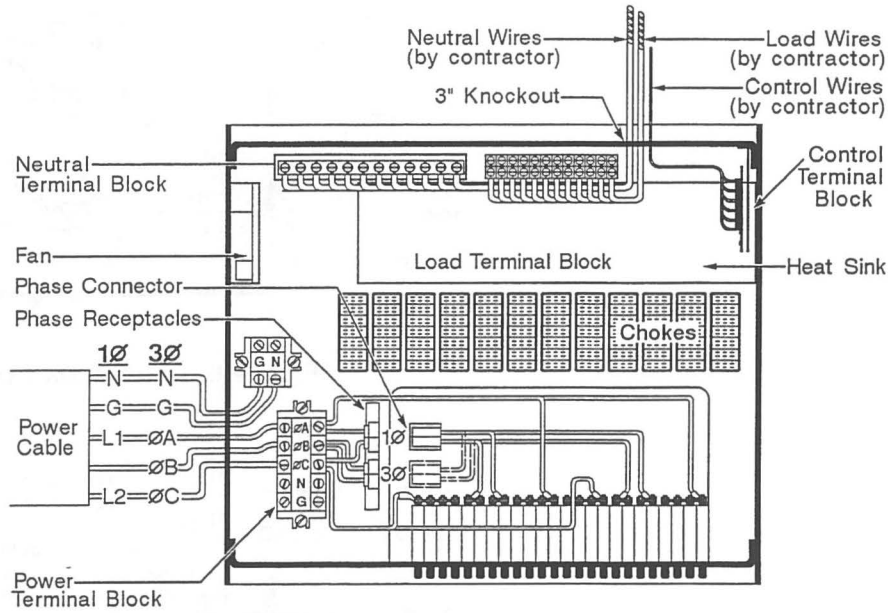

1.2Kw pack shown. The 24 dimmer 2.4Kw pack has the phase change receptacles are on the right side of the circuit breakers.

Figure 4. 24 Dimmer Pack Power Connection

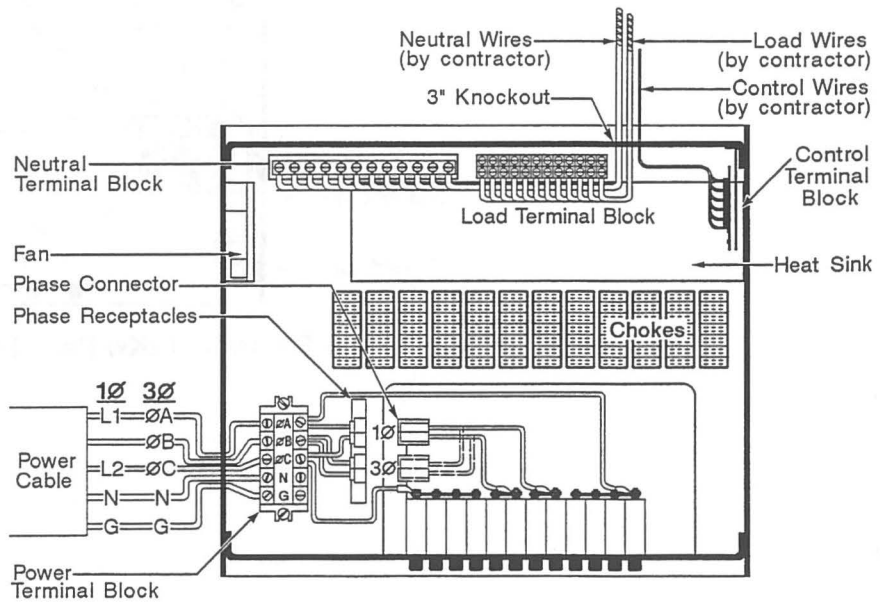

Figure 5. 12 Dimmer 2.4Kw Pack Power Connection

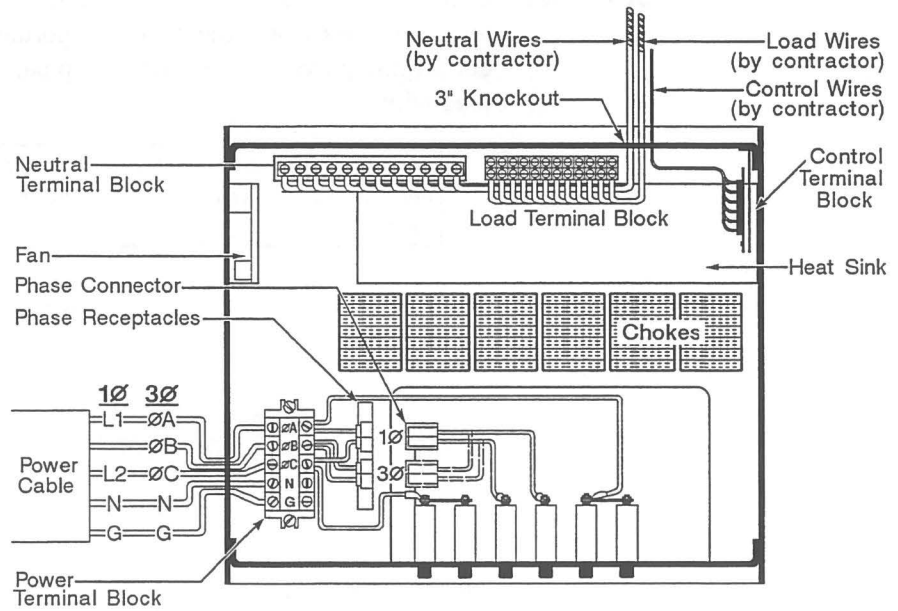

Figure 6. 6 Kw Pack Power Connection

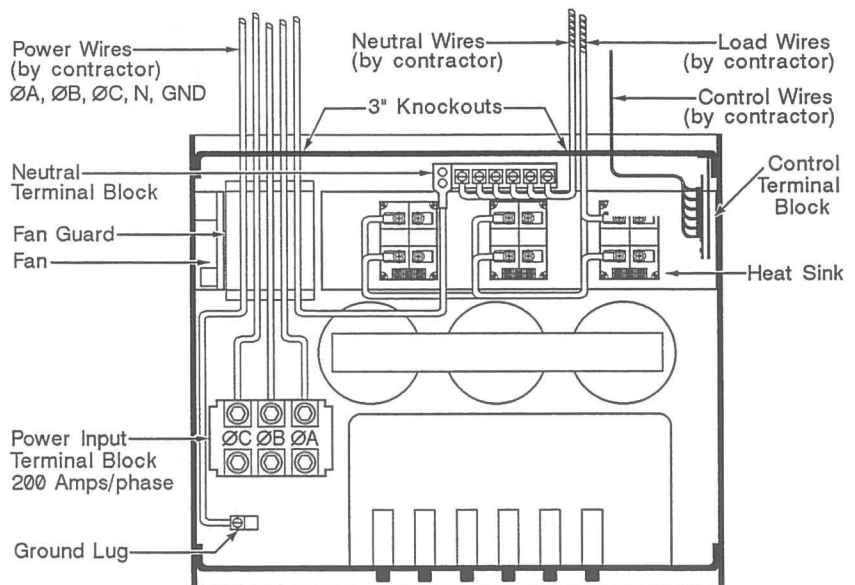

Figure 7. 12Kw Pack Power Connection

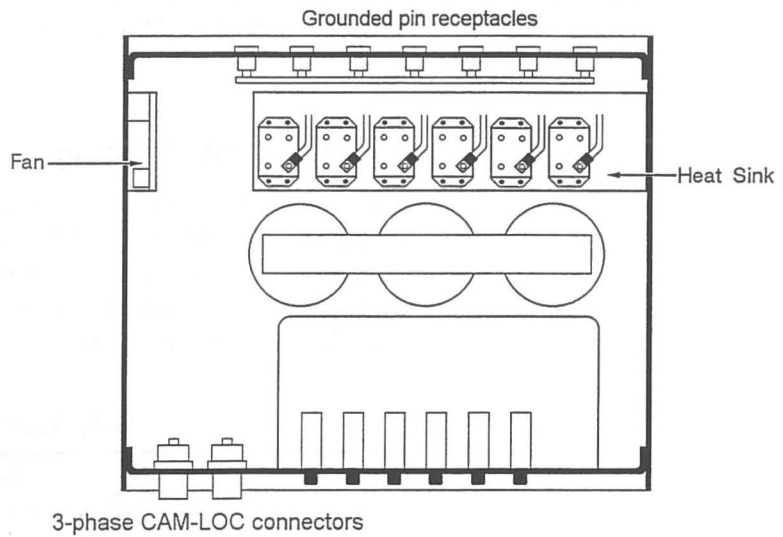

Figure 8. 73230 Pack Power Connection

Connect Load Wires Connect the load wires by plugging them into the rear panel connectors (portable units) or connecting them to the internal terminal blocks (terminal block packs). On 12Kw packs the load wires are connected directly to the solid state relays.

Caution 

These dimmer packs are designed and rated for use with incandescent or inductive loads only. Dimmer packs may be damaged if used with any other type of loads

Connect Control Wires CD80 Digital Dimmer Packs accept control signals conforming to the USITT AMX192 or DMX512 Dimmer Signal Specifications.

AMX192 Control Wiring

The three types of connections provided in Strand Lighting equipment for the AMX192 signal are the XLR style connector, the TA4/TY4 series mini SwitchCraft connector, and terminal blocks. Unless otherwise specified, dimmer cabinets use terminal block connections and consoles use XLR style connectors (see table 1 for pin assignments).

Table 1. AMX192 Control Inputs

Cable:		Belden 9156 or equal. May use Belden 8723 for adapters under 100 feet (30m) long.				
Max Length:		1000 feet (300m). must be Daisy chained - no branching runs.				
Connector:		Terminal block in fixed cabinets and racks. "XLR" style connector, or SwitchCraft TA4/TY4 series connector on moveable racks and packs, and on control consoles.				
XLR Pin #	TA4/TY4 Pin #	Terminal Pin #	Signal	Comments	Belden 8723	Belden 9156
4	1	AMX CLK-	CLOCK -	Clock Complement	Green	Black
2	3	AMX CLK+	CLOCK +	Clock True	White	White
1	2	AMX COM	COMMON	Analog Common	Black	Black
3	4	AMX AMUX	ANALOG	Multiplexed Analog	Red	Red

CLOCK+ and CLOCK- are one twisted pair. Analog and Common are one twisted pair.

There are two AMX192 inputs, labelled "A" and "B." Use only "A" terminals in systems with 192 AMX192 dimmers or less. Use both "A" and "B" terminals for AMX192 systems with more than 192 dimmers.

Interconnection between equipment with different plug types requires an adapter cable in which the plugs are not connected pin to pin (see figure 9).

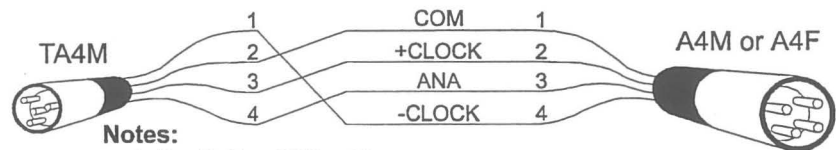

Notes:

1. Use Belden 8763 cable
2. Maximum adapter length = 100 ft. (30m)
3. Sex of "XLR" style connector varies with application

Figure 9. XLR to TA4 Series Adapter

AMX192 adapters (under 100 ft) using TA4/TY4 connectors are made with Belden #8723 cable (2 pairs of shielded 24 AWG wire). All other runs are made with Belden #9156 (2 pairs of unshielded 18 gauge wire).

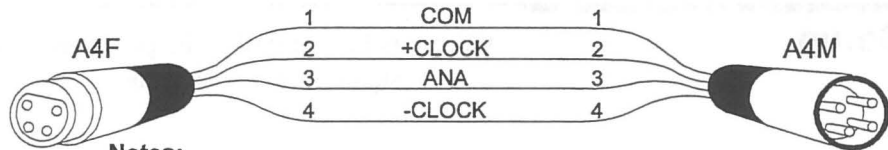

Notes:

1. Use Belden 9156 cable
2. Maximum extension length = 1000 ft. (300m) including all adapters

Figure 10. AMX192 Extension Cable

DMX512 Dimmer Control Wiring

The two types of connections provided in Strand Lighting equipment for DMX512 dimmer control signals are the XLR style connector and terminal blocks. Unless otherwise specified, dimmer cabinets use terminal block connections and consoles use XLR style connectors (see table 2).

Table 2. DMX512 Control Inputs

Cable:		Belden 9829 or equal.			
Max Length:		Standard RS485 electrical characteristics apply, including line driver and receiver characteristics, line loading, and multi-drop configurations.			
Connector:		Terminal block in fixed cabinets and racks. "XLR" style connector on moveable racks and packs, and on control consoles.			
XLR Pin #	Terminal Label	DMX Signal	Comments	Pairs	Wire Color
1	D-GND	COMMON	Dimmer Common (shield)		shield
2	DATA-	DATA 1-	Dimmer Drive Complement	pair 1	black
3	DATA+	DATA 1+	Dimmer Drive True		red
4	Not used	DATA 2-	Optional #2 Data Link Complement	pair 2	black
5	Not used	DATA 2+	Optional #2 Data Link True		white

DATA 1- and DATA 1+ are one twisted pair. Common is tied to the cable shield.

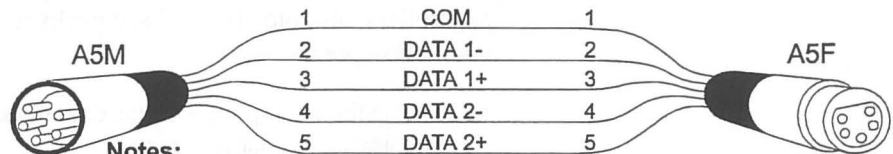

Notes:

1. Use a cable approved for RS485
2. For electrical characteristics, including driver and receiver selection, line loading, and multi-drop configurations, see RS485 specification.

Figure 11. DMX512 Dimmer Control Extension Cable

Setup

Once you have installed the packs they must be set up to correctly read the control signal from the console.

Dimmer Signal Number

The first dimmer signal to which a Digital Pack Controller will respond is set by the thumbwheel switches. When you are using AMX192 control signals and 6Kw dimmers, the Mode Switch 6 on the front panel of the controller can also effect the numbering.

Set the starting dimmer signal number for each pack by setting the thumbwheel switches on the front of the control module to the appropriate dimmer number. The CD80 Digital Pack Controller will start looking at dimmer signals starting with the dimmer signal number set on the thumbwheel switches.

Each pack is completely independent of all other packs. You can set two packs to the same start number if you require more than one physical dimmer for each dimmer number.

You do not have to set the start dimmer number to a boundary divisible by 6 or 12. You can have a 2.4Kw pack set to dimmer 1 (the pack is dimmers 1-12), with the next pack set to dimmer 9 (the pack is dimmers 9-20). This will give you two each of dimmers 9 through 12.

Combining Pack Types

You may use combinations of 1.2Kw, 2.4Kw, 6Kw, and 12Kw packs in the same installation. Make sure that you set the thumbwheel switches to the correct dimmer numbers. Remember that a 6Kw or 12Kw dimmer pack may use either 6 or 12 dimmer signals if you are using AMX192 control, depending on the setting of Mode Switch 6. 1.2Kw packs use 24 dimmer signals.

You can mix packs with analog multiplexed controllers, discreet analog controllers, and old style 1.2Kw packs with CD80 Rack electronics if you take a few precautions:

- Disable the curve jumper on the digital packs used in the system so that dimming curves match (see page 27).
- Be careful about setting pack addressing for different pack types.
- Remember that 6Kw analog multiplexed packs always use 12 dimmer signals.
- The input connector on 6Kw and 12Kw units as supplied by the factory uses every other dimmer signal. If you wish them to be on consecutive channels you must use the console to declare 6Kw/12Kw assignments or have appropriately wired splitter boxes.

Dimmer Number Offset

For purposes of pack dimmer numbering, each control cable from the console is treated as a separate system. The first pack on the second control cable must be set to "001" even though the actual console dimmer number will be the number of dimmers on the first cable plus one.

In DMX512 systems dimmer #1 on control cable #2 is actually console dimmer number 513, since the first cable controls 512 dimmers. For DMX512 systems, this numbering is not affected by any 6Kw dimmers on the first cable.

In AMX192 systems with only 2.4Kw dimmers, numbers on cable 2 are offset by 96 or 192 (depending on the console) and each subsequent cable is offset by an additional 192. This means that dimmer #1 (by the thumbwheel switch) on cable #2 is actually console dimmer 97 or 193 in a system with all 2.4Kw dimmers.

The following Strand Lighting control consoles output only 96 dimmer signals from dimmer output #1, and 192 dimmer signals from all other outputs. Each dimmer declared as 6Kw/12Kw in the control console patch takes up two dimmer signals.

- All versions of Mantrix
- Mantrix Memory
- miniPalette consoles set for 288 dimmer signals or less. When set for more than 288 dimmer signals, these control consoles output 192 dimmer signals from dimmer output #1.
- Lightboard M consoles with AMX192 select jumper installed. Without this jumper Lightboard M outputs 192 dimmer signals from dimmer output #1.
- mini Lightpalette series consoles set for 288 dimmer signals or less. When set for more than 288 dimmer signals, these control consoles output 192 dimmer signals from dimmer output #1.
- Lightpalette, Lightpalette II, and Lightpalette III consoles with software versions V6E and higher set for 288 dimmer signals or less. When set for more than 288 dimmer signals these control consoles output 192 dimmer signals from dimmer output #1.

Strand Lighting Light Palette Series consoles with software revisions V5A, V5B, V6A and V6B output 96 dimmer signals from all control console outputs when set for 384 dimmer signals or less. When set for more than 384 dimmer signals, these control consoles output 192 dimmer signals from each output.

Very early Mantrix production consoles may not be compatible for 6Kw/12Kw Pack operation. If not, consult Strand Lighting.

Caution



When you are using AMX192 control signals, a 6Kw or 12Kw Pack uses 12 dimmer signals when Mode Switch 6 is OFF. This simulates the analog multiplexed pack control module for easy retrofitting. You must have 6Kw/12Kw dimmers declared in your control console patch for this setup to work correctly. This also skews the dimmer offset for the next control cable. For each 6Kw or 12Kw pack set up in this manner, the dimmer offset is decreased by 6 dimmers, since 6 dimmer signals are wasted per pack.

If Mode Switch 6 is ON, the 6Kw or 12Kw Pack only uses 6 dimmer signals. You should **not** have 6Kw/12Kw dimmers declared in your control console patch if you are using this setting. This method does not skew the dimmer offset for the next cable, since all dimmer signals are being used.

You can set some 6Kw or 12Kw packs for 6 signals and some for 12 signals as long as you adjust appropriately in your control console patch. However, it is generally less confusing if all 6Kw/12Kw adjustments are in patch or all are in the pack controllers. If you have some Analog Multiplexed Pack Controllers and some Digital Pack Controllers it is generally less confusing if you set all of the digital controllers to mimic the analog controllers (Mode Switch 6 is OFF).

Set 6Kw/12Kw Control Mode

In order to maintain compatibility with older Strand Lighting equipment and procedures, you can set the CD80 Digital Pack Controller to use consecutive incoming signals or use only every other signal. The factory default setting for this switch is ON.

Use Every Control Signal (default)

To use every control signal for dimmer levels, set Mode Switch 6 to ON (push in at the top of the switch). In this mode, the controller will use the first 6 signals starting from the thumbwheel dimmer number for 6Kw packs, and the first 12 signals for 2.4Kw packs. **You should always use this setting for 1.2Kw or 2.4Kw Packs.**

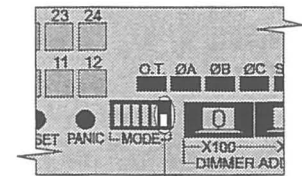

Set Mode switch 6 ON
(push in at top)

Use Every Other Control Signal

To use every other control signal for dimmer levels, set Mode Switch 6 to OFF (push in at the bottom of the switch). This setting is for Strand Lighting systems where the 6Kw assignment is being made in the console. Since 2 consecutive signals are output for each 6Kw dimmer assigned in the console, the CD80 Digital Pack Controller will use every other signal starting with the thumbwheel dimmer number. This setting is for retrofit situations where you already have 6Kw dimmers set in the console and do not wish to reset the patch. **You should not use this setting in 1.2Kw or 2.4Kw Packs.**

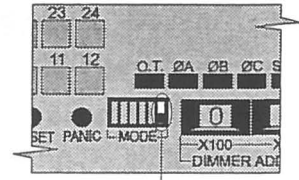

Set Mode switch 6 OFF (push in at bottom)

Set Dimmer Curve

The CD80 Digital Pack Controller can be set so that its output curve matches CD80 Multiplexed Analog and Discreet Analog Controllers, or can be set with a modified square law curve which allows smoother control at the lower end of the dimming curve. The setting is made with a jumper. The factory default for this jumper is INSTALLED (modified square law curve).

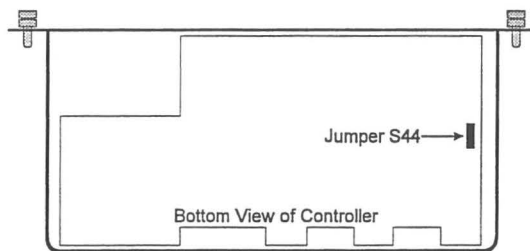
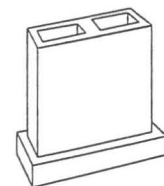

Figure 12. Dimmer Curve Jumper Location

Modified Square Law Curve (default)

1. Make sure power to the pack is OFF.
2. Remove the Digital Pack Controller from the pack and locate jumper S44 (see figure 12 on page 27).
3. Install jumper S44 as shown.
4. Install the Digital Pack controller back in the pack.
5. Turn power to the pack back ON.



Enable S44

Analog Pack Matching Curve

1. Make sure power to the pack is OFF.
2. Remove the Digital Pack Controller from the pack and locate jumper S44 (see figure 12 on page 27).
3. Move jumper S44 as shown so that it is inactive.
4. Install the Digital Pack controller back in the pack.
5. Turn power to the pack back ON.

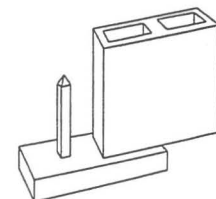

Disable S44

**Using AMX192
Dimmer Control**

Figure 13 shows a typical system hookup using AMX192 control signals. Note that the 6Kw pack on output #1 (pack #3) is configured for skipping every other control signal. This skews the numbering, so that dimmer 31 (pack #4) is actual controlled by control signal #37. The 6Kw pack on output #2 (pack #10) is set to use every signal. This keeps the thumbwheel numbering consistent with the actual dimmer signal used in each pack.

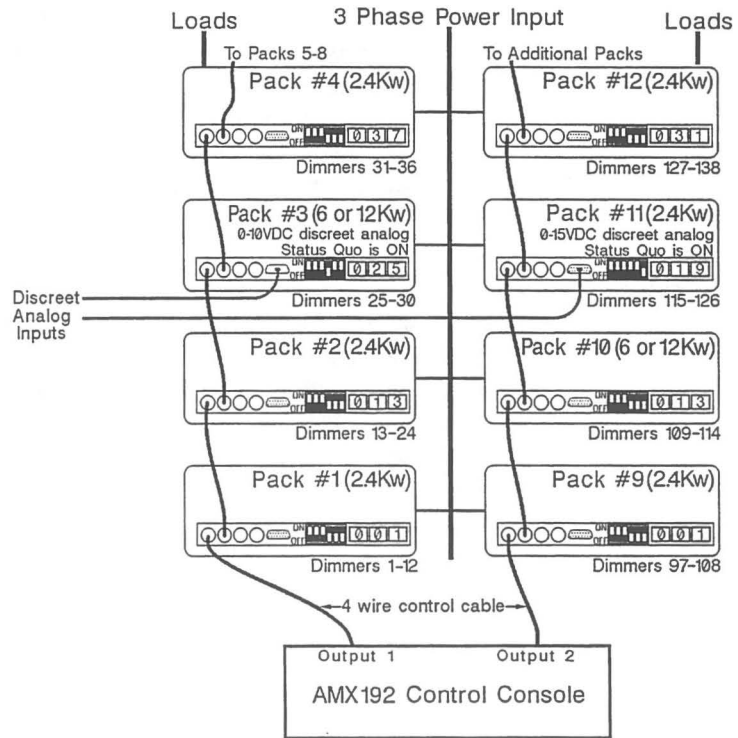

Figure 13. Connect Packs for AMX192

Using DMX512 Dimmer Control

Figure 14 shows a typical system hookup using DMX512 control signals. Since each DMX512 control cable transmits signals for 512 dimmers, there will seldom be a need for more than one control cable in a typical pack application. If you need a second cable, the first pack on the second cable should be set to "001" just as it is with AMX192 systems.

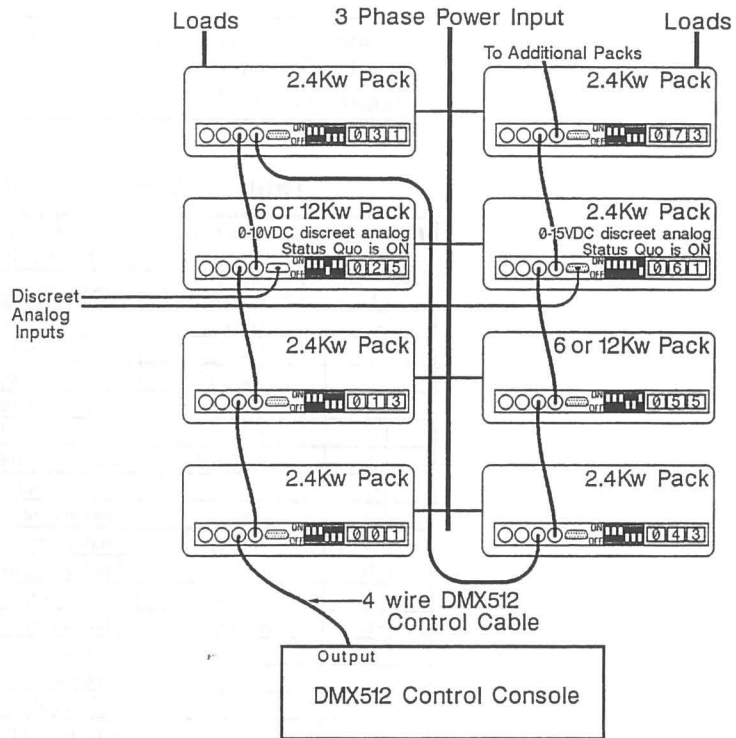

Figure 14. Connect Packs for DMX512

Discreet Analog Control Hookup

The CD80 Digital Pack Controller has a discreet analog input for each control channel which can be piled on to the dimmer levels from the selected incoming protocol. These signals are input through standard DB15 connectors on the front of the controller. 24 channel controllers use two DB15 connectors. Table 3 shows the pinouts of this connector.

These signals also appear at the rear of the pack on hard wired 1.2Kw and 2.4Kw packs, and at the rear of 6Kw and 12Kw packs produced starting in 1997.

Table 3. Discreet Analog Input Connections

Connector: Male DB15 connector (there are 2 connectors on 24 channel controller, shown as pins 2-1 through 2-15 in this table)		
Pin #	Signal Name	Description
1-1	Analog 1	Analog control for dimmer 1
1-2	Analog 2	Analog control for dimmer 2
1-3	Analog 3	Analog control for dimmer 3
1-4	Analog 4	Analog control for dimmer 4
1-5	Analog 5	Analog control for dimmer 5
1-6	Analog 6	Analog control for dimmer 6
1-7	Analog 7	Analog control for dimmer 7
1-8	Analog 8	Analog control for dimmer 8
1-9	Analog 9	Analog control for dimmer 9
1-10	Analog 10	Analog control for dimmer 10
1-11	Analog 11	Analog control for dimmer 11
1-12	Analog 12	Analog control for dimmer 12
1-13	GND	Ground
1-14	GND	Ground
1-15	+12V	+12V feed for analog
2-1	Analog 13	Analog control for dimmer 13
2-2	Analog 14	Analog control for dimmer 14
2-3	Analog 15	Analog control for dimmer 15
2-4	Analog 16	Analog control for dimmer 16
2-5	Analog 17	Analog control for dimmer 17
2-6	Analog 18	Analog control for dimmer 18
2-7	Analog 19	Analog control for dimmer 19
2-8	Analog 20	Analog control for dimmer 20
2-9	Analog 21	Analog control for dimmer 21
2-10	Analog 22	Analog control for dimmer 22
2-11	Analog 23	Analog control for dimmer 23
2-12	Analog 24	Analog control for dimmer 24
2-13	GND	Ground
2-14	GND	Ground
2-15	+12V	+12V feed for analog

Set Analog Pile-on Mode

The 12 analog signals can be piled on in the standard "highest takes precedence" manner or in such a way that the dimmer output level is the analog signal level plus the protocol level. The factory default setting for this switch is OFF.

Analog Plus Protocol

To set the pile-on mode to "Analog Plus Protocol," set Mode Switch 3 to ON (push in at the top of the switch). In this mode, the controller adds the level from the discrete analog input and the multiplexed protocol input and passes the sum to the dimmer.

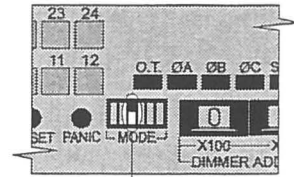

Set Mode switch 3 ON (push in at top)

Highest Takes Precedence (default)

To set the pile-on mode to "Highest Takes Precedence," set Mode Switch 3 to OFF (push in at the bottom of the switch). In this mode, the controller looks at the incoming discrete analog level, and the incoming multiplexed level, and passes the higher of the two levels to the dimmer.

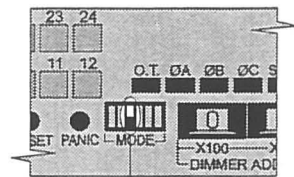

Set Mode switch 3 OFF (push in at bottom)

Set Analog Input Level

In order to function with a wide variety of analog controllers, the CD80 Digital Pack Controller can process either zero to +10VDC or zero to +15VDC signals from the discrete analog inputs. The factory default setting for this switch is ON.

Zero to +10VDC (default)

To set the controller for an analog input signal level of zero to +10VDC, set Mode Switch 4 to ON (push in at the top of the switch). This will allow it to recognize the analog signals from Strand Lighting and many other manufacturers' control consoles.

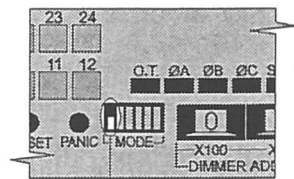

Set Mode switch 4 ON (push in at top)

Zero to +15VDC

To set the controller for an analog input signal level of zero to +15VDC, set Mode Switch 4 to OFF (push in at the bottom of the switch). This will allow it to recognize the analog signals from Strand Electro Control consoles.

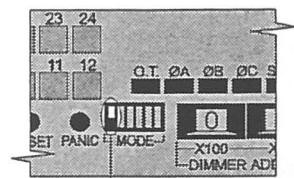

Set Mode switch 4 OFF (push in at bottom)

Set "Status Quo"

The CD80 Digital Pack Controller can "remember" the stage levels for 30 minutes after the control signal is lost or turned OFF. The factory default setting for this switch is ON (Status Quo is OFF).

"Status Quo" OFF (default)

To turn the "Status Quo" function OFF set Mode Switch 5 to ON (push in at the top). When this switch is ON the dimmers will all go OFF immediately after loss of control signal.

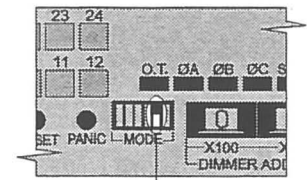

Set Mode switch 5 ON
(push in at top)

"Status Quo" ON

To turn the "Status Quo" function ON set Mode Switch 5 to OFF (push in at the bottom). When this switch is OFF the controller will retain the last known dimmer levels for 30 minutes after loss of control signal. This function is particularly handy for house lights, and will allow you to turn OFF the console and leave, knowing that the lights will turn themselves OFF after 30 minutes. This function will also maintain stage lighting for long enough to bring in another console in case of an equipment failure.

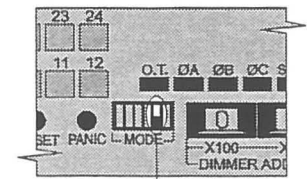

Set Mode switch 5 OFF
(push in at bottom)

Fault Protection

If the SSR heat sink overheats, the OverTemp indicator will turn ON and the pack will shut down. This shows that air flow has been blocked or the fan has failed.

Electromagnetic circuit breakers protect the SSRs if there is a dead short, (defined as .02 ohms or less) across 40 feet of #14 AWG load wires. A short on any dimmer in the pack will trip the circuit breaker for the dimmer OFF. You can restore circuit operation by clearing the short and turning the circuit breaker back ON.

Hot Pocket

On 12 dimmer 2.4Kw packs, 6Kw packs, and 12Kw packs you can check your load wiring for shorts by using the "hot Pocket" on the back of the pack. This receptacle is wired directly to the last circuit breaker (#6 on 6Kw or 12Kw dimmers and #12 on 2.4Kw dimmer) and connected in parallel to the "test outlet" pilot light.

On 12 dimmer 2.4Kw packs this "hot pocket" is the 24th receptacle (the second receptacle for dimmer #12). You can convert the "hot pocket" to normal dimmer output by moving the power lead for receptacle 24 from the AC input terminal of SSR #12 to its output terminal.

On 6Kw and 12Kw packs, there is a seventh receptacle wired directly to circuit breaker #6.

There is no "hot pocket" on 24 dimmer packs but you can turn dimmers full ON for testing by using the ON/NORMAL pushbuttons on the front of the controller.

This feature also aids in trouble shooting by isolating faults to either the user load or the CD80 Digital Pack.

Local Dimmer Control

Dimmers attached to a CD80 Digital Pack can be turned ON and OFF locally by using either the PANIC switch or the individual ON/NORMAL pushbuttons.

Dimmer Panic

The alternate action PANIC switch lets you turn all dimmers in the pack ON if required.

Use a bent paper clip or other thin probe to press the PANIC switch ON. Press the switch again to return to normal dimmer control.

ON/NORMAL Pushbuttons

Each dimmer output can be switched ON using the ON/NORMAL pushbutton associated with the dimmer.

Press the required pushbutton to turn the associated dimmer ON. Press the pushbutton again to return the dimmer to normal dimmer control.

Mode Switch Settings

The 6 position Mode Switch allow various control parameters to be changed as required. Individual switch settings are discussed earlier in this chapter.

Table 4. Mode Switch Settings

Position/ Condition	Effect
Position 1 OFF Position 1 ON	reserved reserved
Position 2 OFF Position 2 ON	three phase operation single phase operation
Position 3 OFF Position 3 ON	dimmer level is the higher of analog and protocol (pile-on) dimmer level is analog + protocol
Position 4 OFF Position 4 ON	0-15VDC analog input level 0-10VDC analog input level
Position 5 OFF Position 5 ON	30 minute output "Status Quo" when signal is lost immediate blackout if signal is lost
Position 6 OFF Position 6 ON	uses every other control signal starting with the thumbwheel number uses the first 12 control signals starting with the thumbwheel number

Factory default settings are shown in bold in this table.

Retrofitting an Analog Pack

The 12 channel CD80 Digital Pack Controller (Cat. #8216) is a direct replacement for the CD80 Multiplexed Analog Pack Controller (part #3-258358-010) and the CD80 Discreet Analog Pack Controller (part #3-358362-010). It is very easy to retrofit a 12 channel CD80 Digital Pack Controller into an older CD80 Digital Pack to provide compatibility with a larger variety of control signals.

1. Make sure that power to the pack is OFF
2. Remove the old controller from the pack.
3. Set the curve jumper as required on the new controller (see 27).
4. If you are going to set the controller to use every other channel for 6Kw or 12Kw packs, attach the switch label provided with the retrofit kit. If the pack controller will be used in multiple applications it is probably better not to attach this label.
5. Set the Mode switches as required.
6. Install the new controller in the pack.
7. Turn power to the pack back ON.

Basic Troubleshooting

This chapter provides basic troubleshooting procedures for the CD80 Digital Pack Controller. It does not provide comprehensive maintenance data, but allows you to solve simple problems which may occur, and helps to provide Strand Lighting with initial data when these procedures are not effective.

For best system operation, do a routine check and cleaning once each year unless the operating environment is unusually harsh or dirty. Please consult Strand Lighting field Service if you are in doubt about the frequency of maintenance required for your system. Service and maintenance operations other than this cleaning are seldom required. In case of problems, and in order to save time and aggravation, follow the procedures outlined here before calling Strand Lighting. Observe what happens at each step. These steps answer the first questions a Strand Lighting Service Representative will ask. The person actually doing the tests should call Strand Lighting in order to avoid confusion and misunderstanding.

Each section of this chapter describes a possible failure mode and actions to be taken. If all actions fail, please call the appropriate Strand Lighting office.

Component Removal

The CD80 Digital Pack has been designed to be serviced easily and quickly by the customer.

Controller Replacement

The Digital Pack Controller can be removed and installed without disconnecting any wiring.

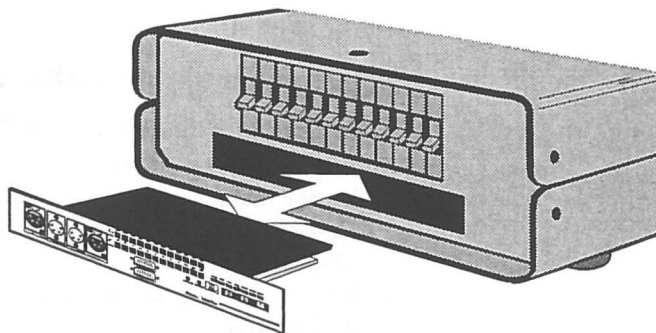

Figure 15. Digital Dimmer Controller Removal

Removing the Controller

1. Turn power to the dimmer pack OFF.
2. Loosen two thumbscrews (on opposite ends of the controller).
3. Pull on the thumbscrews to remove the controller.

Installing the Controller

1. Turn power to the dimmer pack OFF.
2. Line the controller up with guides on each side of the slot.
3. Slide the module in carefully until it touches the connector in the pack.
4. Firmly seat the controller by pressing on both ends of the module.

SSR Replacement Single dimmer failures are usually caused by Solid State Relay (SSR) failure. Replacement of SSRs requires removal of the pack cover.

Caution



Clean and coat the SSR mounting surface with thermal compound (Wakefield 120-8 or equivalent) before replacing it on the heat sink.

Replacing a dual 1.2Kw or 2.4Kw SSR

1. Turn power to the dimmer pack OFF.
2. Remove the pack cover.
3. Unplug the control connector (A) from the SSR.
4. Remove the choke and load lugs (B) from the SSR. Make sure you write down where each of the wires was terminated.
5. Remove the relay mounting screws and lock washers (D).
6. Lift the SSR away from the heat sink.
7. **Make sure that the current rating of the replacement SSR matches the current rating of the SSR you are replacing.**
8. To install the new SSR, reverse the above procedure.

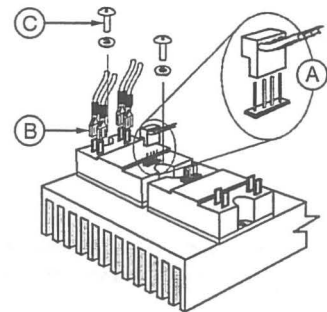

Replacing a single 2.4Kw or 6Kw SSR

1. Turn power to the dimmer pack OFF.
2. Remove the pack cover.
3. Loosen (do not remove) the control screws (A) and the choke and load terminal screws (B & C).
4. Remove the relay mounting screws and lock washers (D).
5. Slide the SSR away from the control PCB and lift it out.
6. **Make sure that the current rating of the replacement SSR matches the current rating of the SSR you are replacing.**
7. To install the new SSR, reverse the above procedure.

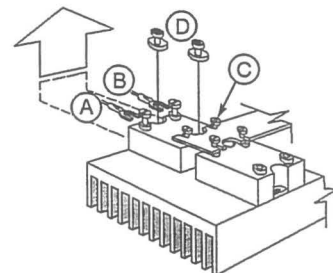

Replacing a 12Kw SSR

1. Turn power to the dimmer pack OFF.
2. Remove the pack cover.
3. Disconnect the control wires (A) from their terminals. The positive lead is colored and the negative lead is black.
4. Remove the choke and load terminal screws (B & C).
5. Remove the relay mounting screws and lock washers (D).
6. Lift the SSR away from the heat sink.
7. **Make sure that the current rating of the replacement SSR matches the current rating of the SSR you are replacing.**
8. To install the new SSR, reverse the above procedure.

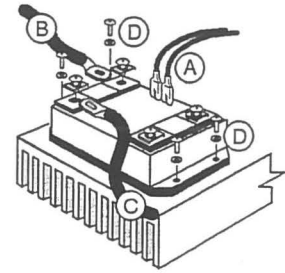

Changing other components

The electrical and mechanical components, relays, chokes, breakers, connectors, fan and phase changer are accessible by simply removing the top cover. The relays are fastened from above into the heat sink by two screws and are easily replaced by the customer by removing the two screws and loosening four screw terminal wire connectors.

Problems Affecting the Entire Pack

Problems which affect the entire pack are usually related to incorrect power or control hookup, open fuses, or overheating of the pack.

No phase LED lit

- Controller may not be seated correctly. Remove and reinstall the controller.
- Fuse F1 (phase A) may be open. Replace with a .250A fast blow fuse if required.
- If the fuses are all OK and you can turn the dimmers on with their individual pushbuttons, the module is defective. Replace it with a spare and return the defective unit to Strand Lighting for repair.

Phase B or C LED not lit

- Fuse F2 and/or Fuse F3 is probably open. Replace with equivalent fuse.

All phase LED lit but no Protocol indication

- Incoming control wiring may be miswired or one or more conductors broken.

No control of dimmers (dimmers are always OFF)

- If the OverTemp light is ON, the pack has shut down from overheating. Make sure that the air intake and exhaust are not blocked and wait for the thermostat resets.
- The thumbwheel switches may be set to an incorrect address. Check the settings and correct as required.

No control of dimmers (dimmers are always ON)

- The PANIC switch may be ON or one or more individual pushbuttons may be ON.

Problems Confined to a Single Phase

Problems which are confined to a single phase are usually related to Controller problems or to the dimmer pack being incorrectly set up for the type of power in use.

Four consecutively numbered dimmers will not go ON

- The power feed for the phase may be OFF or not connected.
- The control module may be incorrectly inserted. Remove it and carefully re-insert it into the dimmer pack.
- One or more output control circuits may have failed. Swap the Controller with a known good spare. If the problem goes away, return the defective Controller to Strand Lighting for repair.

One or more dimmers on the same phase do not come up to full or do not track correctly

- The phase change switch or Mode Switch 2 may be incorrectly set. Make sure that the pack is set up for the type of AC power you are using.
- The phase fuse may be open (F2 for phase B and F3 for phase C). Check the fuses and replace if necessary. Since the phase A fuse (F1) powers the electronics as well as providing a phase reference, an open phase A fuse will completely disable the pack.
- One or more output control circuits may be defective. Replace the defective Controller with a spare and return the defective unit to Strand Lighting for repair.

Individual Dimmer Problems

Problems relating to individual dimmers are due to one of the following:

- Dimmer Circuit Breaker is OFF
- Burned out lamp in fixture.
- Defective or disconnected load wiring.
- Defective Controller module.
- Defective discreet analog control wiring.
- Defective SSR, circuit breaker, or choke (probably the SSR).

Check for a load wiring problem or burned out lamp by turning the ON/NORMAL switch for the dimmer ON or by moving the suspect load to a known good dimmer. If the problem remains, repair the problem in the load circuit or lamp.

Check for a defective Controller module by swapping it with a known good unit from another pack. Make sure that the Mode switches are set the same way before replacing the Controller module. If the problem goes away with the new module, replace the defective Controller module with a spare and return the defective unit to Strand Lighting for repair.

Check for a defective SSR, choke, or circuit breaker by checking the voltage at the circuit breaker output, choke output, and SSR output with the dimmer ON. The component with an input but no output is defective. Replace the defective component.

If the dimmer works from the console (protocol input) but not from the discreet analog input, there is a problem in the discreet analog circuitry, probably external to the pack.

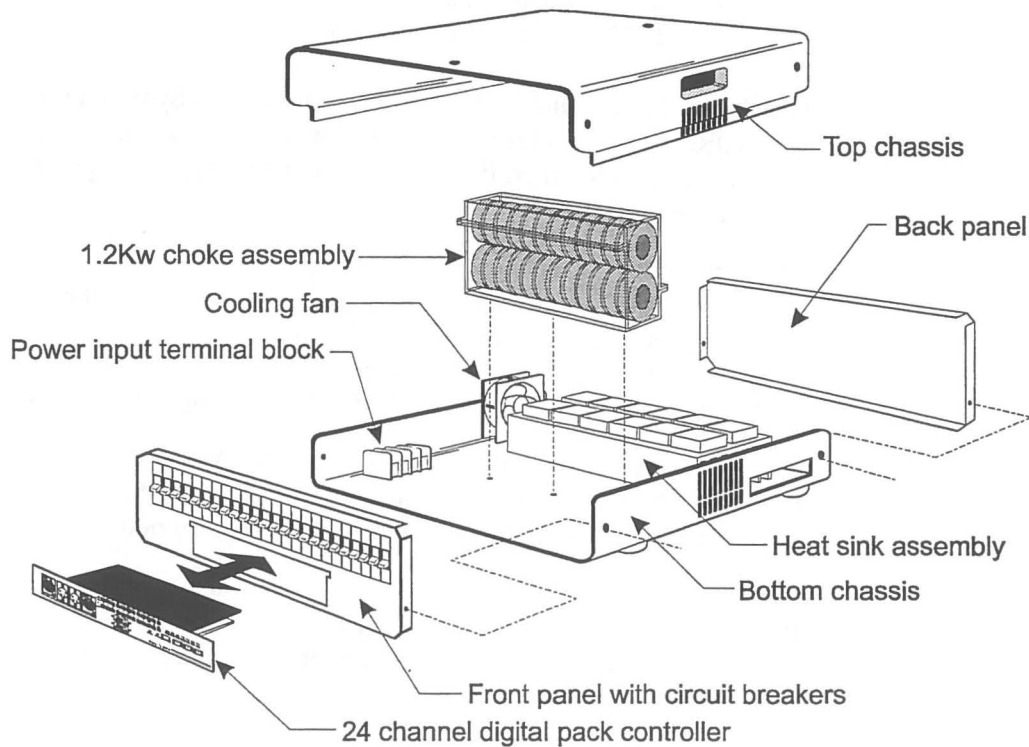

Figure 16. 24 Dimmer Digital Pack Parts

Table 5. Repair Parts for 24 Dimmer Digital Pack

Part Number	Description
76470	24 channel Digital pack Controller
1-377213-010	Dual 40A Solid State Relay (1.2Kw and 2.4Kw packs)
2-169040-010	1.2Kw choke (1.2Kw pack only)
2-169071-010	2.4Kw choke (2.4Kw pack only)
1-260014-010	Cooling fan (4" dia, 105cfm, 115VAC)
2-225008-010	3-pole 20A pin connector (1.2Kw and 2.4Kw packs)
1-228021-000	3-pole 20A GTL connector (1.2Kw and 2.4Kw packs)
1-228060-000	3-Pole 20A U-ground connector (1.2Kw and 2.4Kw packs)
1-228062-010	3-Pole 15A U-ground connector (1.2Kw packs only)
1-230017-000	Multi-pin connector (VEAM 19-pin--1.2Kw and 2.4Kw packs)

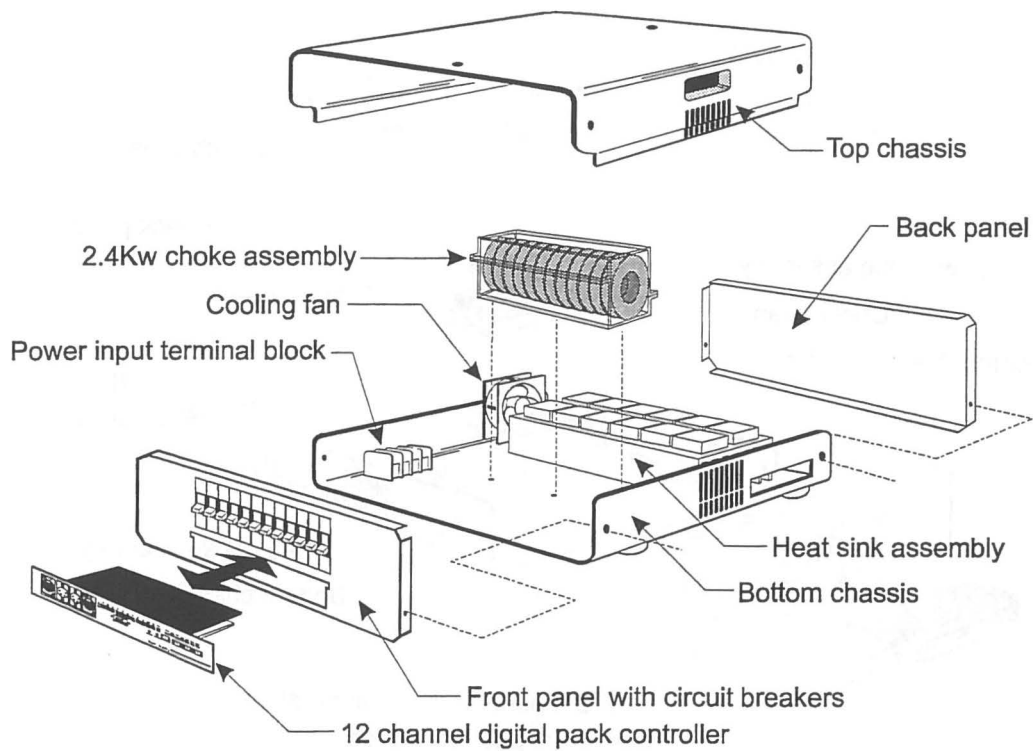

Figure 17. 12 Dimmer 2.4Kw Digital Pack Parts

Table 6. Repair Parts for 12 Dimmer 2.4Kw Digital Pack

Part Number	Description
76471	12 channel Digital pack Controller
2-377003-010	Single 40 amp Solid State Relay
2-169029-010	2.4Kw choke
1-260014-010	Cooling fan (4" dia, 105cfm, 115VAC)
2-225008-010	3-pole 20A pin connector
1-228021-000	3-pole 20A GTL connector
1-228060-000	3-Pole 20A U-ground connector
1-230017-000	Multi-pin connector (VEAM 19-pin)

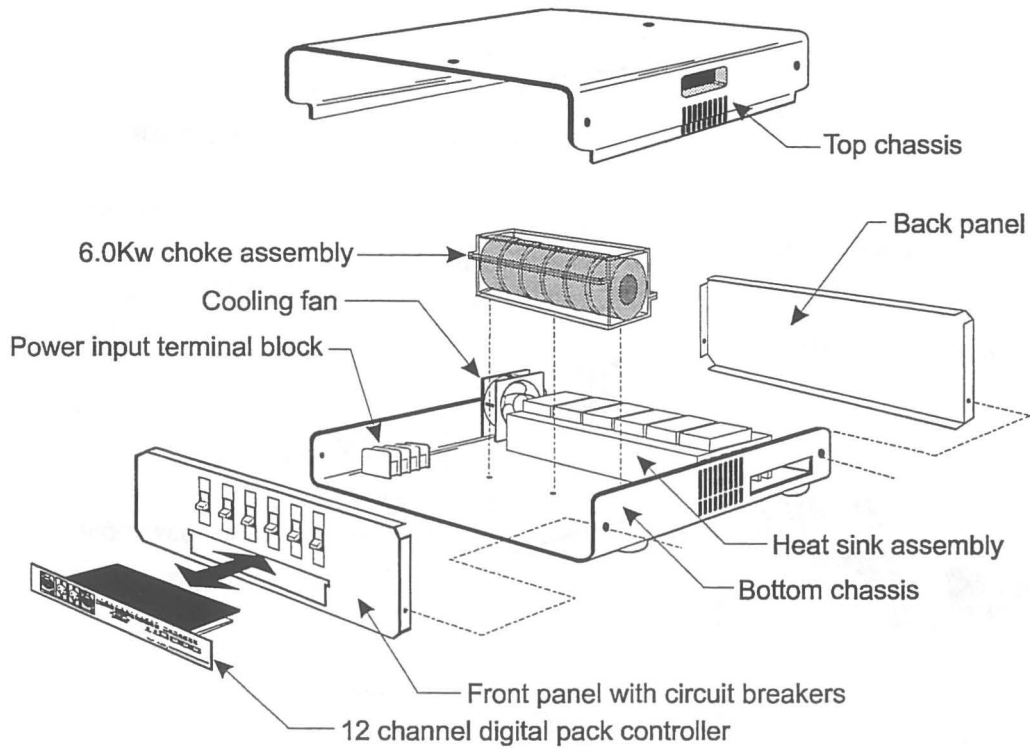

Figure 18. 6Kw Digital Pack Parts

Table 7. Repair Parts for 6.0Kw Digital Pack

Part Number	Description
76471	12 channel Digital pack Controller
2-377002-010 or 2-377007-010	80 amp Solid State Relay
2-169026-010	50 amp choke
1-260014-010	Cooling fan (4" dia, 105cfm, 115VAC)
2-225003-010	3-pole 50A pin connector
1-228031-000	3-pole 50A GTL connector

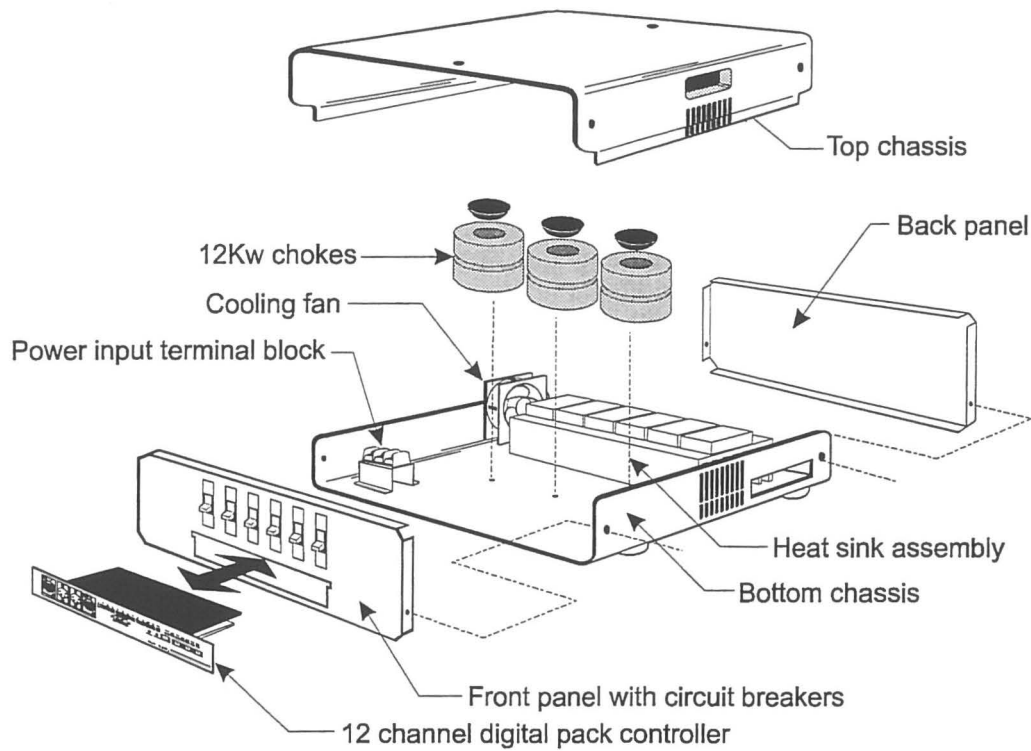

Figure 19. 12Kw Digital Pack Parts

Table 8. Repair Parts for 12Kw Digital Pack

Part Number	Description
76471	12 channel Digital pack Controller
1-377199-000	125 amp Solid State Relay
2-169027-010	100 amp choke
1-260014-010	Cooling fan (4" dia, 105cfm, 115VAC)
2-225006-010	3-pole 100A pin connector



Periodic Maintenance

Periodic Maintenance should be done every six (6) to twelve (12) months, depending on the environmental conditions. Although a detailed discussion of this procedure is beyond the scope of this manual, basic checklists are provided to show what is involved. Users wishing to do these procedures on their own should consult Strand Lighting Field Service.

1. Turn power to the dimmer pack OFF.
2. Inspect the dimmer pack for loose connections, build-up of dust, and (for permanent or semi-permanent installations) placement of obstructions around it which may impede air flow. Tighten any loose connections found at this time.
3. Vacuum out any excessive dust build-up in the dimmer pack while power to the pack is shut down.
4. Remove the Control Module from the pack, dust it off with a soft natural bristle brush, and clean its edge connectors with a mixture of 70% denatured alcohol and 30% distilled water (or other cleaning compound intended for gold edge connectors).
5. Exercise all circuit breakers by turning them ON and OFF several times. The arc produced when the circuit breakers engage and disengage will clean corrosion and dust off of the contacts.

For best effect the lights for the dimmers should be ON when you do this.

6. Replace Control Module.
7. Turn power to the system ON and verify proper functioning.

Index

6Kw/12Kw control mode 25

A

AC Power 15
install 19
Adapter
XLR to TA4 series 21
Adapter cable
AMX192 21
XLR to TA4 series 21
AMX192
adapter cable 21
control inputs 21
control wiring 21
example 27
extension cable 22
Analog input 6
Analog input level
Zero to +10VDC 30
Zero to +15VDC 30
Analog Plus Protocol 30
Approval
CSA 13

B

Bump 2

C

Cable
AMX192 adapter 21
XLR to TA4 adapter 21
Channel 2
Chassis 10
Circuit 2
Circuit breakers 31
Combining pack types 23
Comments 3
Conduit entry area 17
Connectors
output 6
Control inputs
AMX192 21
DMX512 22
Control wiring
AMX192 21
discreet analog 29
DMX512 dimmer 22

install 21
Controller
replace 35
Conventions 3
Cooling 12
Crossfade 2
CSA approval 13
Cue 2

D

Definitions 2
Description
Chassis 10
cooling 12
Digital Pack Controller 11
dimmer pack types 13
power control 12
Digital Controller 11
Dimmer 2
analog pack matching curve 26
modified square law curve 26
output curve 6, 26
output rise time 6
output waveform 6
response time 6
Dimmer control
AMX192 27
DMX512 28
Dimmer level retention 7
Dimmer module
efficiency 6
output regulation 6
Dimmer number offset 24
Dimmer pack
heat dissipation 15
install 17
types 13
Dimmer protocol 5
Dimmer start address 24
Discreet Analog
wiring 29
DMX512
control inputs 22
dimmer control wiring 22
example 28
Extension Cable 22
Down-fade 2

E

- Efficiency 6
- efficiency 15
- Environmental considerations 15
- Extension cable
 - AMX192 22
- Extension Cable
 - DMX512 22

F

- Fade 2
- Fault protection 31

H

- Hardware Description 9
- Heat dissipation 15
- Highest Takes Precedence 30
- Hot pocket 32

I

- Input
 - AMX192 21
 - analog 6
 - discreet analog 29
 - DMX512 22
- Input level
 - Discreet analog 30
- Installation
 - AC Power 19
 - AMX192 control wiring 21
 - AMX192 dimmer control 27
 - combining pack types 23
 - control wiring 21
 - convert from analog 33
 - dimmer pack 17
 - discreet analog inputs 29
 - DMX512 control wiring 22
 - DMX512 dimmer control 28
 - load wiring 20
 - power wiring 19
 - set 6Kw/12Kw control mode 25
 - set analog pack matching curve 26
 - set dimmer number offset 24
 - set dimmer output curve 26
 - set discreet analog input level 30
 - set for single phase 18
 - set for three phase 18

- set Mode Switches 33
- set modified square law curve 26
- set pile-on mode 30
- set Status Quo mode 31
- set thumbwheel switches 23
- Introduction and Assistance 1

L

- Layout
 - conduit routing 17
 - positioning packs 16
- Listing
 - UL 13
- Load wiring
 - install 20
- Local dimmer control 32

M

- Manual Organization 1
- Memory 2
- Mode Switch settings 33

O

- ON/NORMAL switch 32
- Operational Features 5
- Output connectors 6
- Output curve 6, 26
- Output regulation 6
- Output response time 6
- Output rise time 6
- Output waveform 6

P

- PANIC switch 32
- Parts purchases 3
- Patch 2
- Periodic Maintenance 45
- Pile-on mode
 - Analog Plus Protocol 30
 - Highest Takes Precedence 30
- Planning
 - conduit routing 17
 - cooling requirements 15
 - environment 15
 - positioning packs 16
 - power requirements 15
- Positioning 16
- Power control 12

Power requirements
 single phase 15
 three phase 15
Power wiring
 install 19
Preparation 15
Preset 2
Problems 3
Protocol 5
Push-button
 ON/NORMAL 32

Q

Questions 3

R

Regulation 6
Replace
 controller 35
 SSR 36
Response time 6
Retrofitting an analog pack 33
Rise time 6

S

Set
 6Kw/12Kw control mode 25
 analog pack matching curve 26
 dimmer number offset 24
 dimmer output curve 26
 discreet analog input level 30
 Mode Switches 33
 modified square law curve 26
 pile-on mode 30
 Status Quo mode 31
 thumbwheel switches 23
Setup
 set for single phase 18
 set for three phase 18
Single phase operation 15, 18
SSR
 replacement 36
Status Quo 31
Status Quo memory 7
Submaster 2
Suggestions 3
Switch
 ON/NORMAL 32
 PANIC 32

T

TA4 connector 21
Technical Assistance 3
Temperature 15
Three phase operation 15, 18
Thumbwheel switches 23
Troubleshooting 35

U

UL listing 13
Up-fade 2

X

XLR connector 21, 22

