

CCT theatre lighting

zoom profile Silhouette 1000 10 base down



9° ↔ 21°

Silhouette profile spotlights are probably the most advanced to be found anywhere.

As first choice for those who know lighting, Silhouette profiles are to be found in every corner of the world.

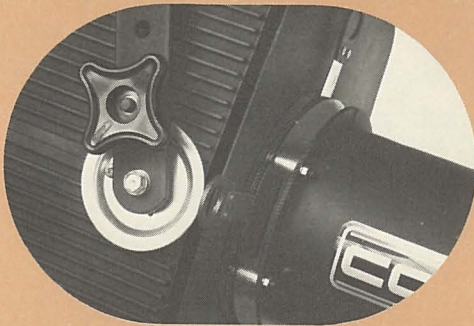

Yoke height adjustment

The lamphouse, constructed in aluminium extrusions and castings is robust with good convection cooling and can be used with a range of interchangeable zoom lens tubes. The Silhouette 1000 10 can be precisely adjusted between 9° and 21° allowing a wide range of beam angles over the same throw distance. The patented aspheric reflector and lamp socket can be externally trimmed for 'peaky' or 'flat' beam. A unique plug-in lamp tray allows cleaning and replacement without the need to change the spotlight orientation. Profiling gate has 4 built-in tempered stainless steel shaping shutters with heat resisting ring handles and there are separate runners for iris and Gobo holder.

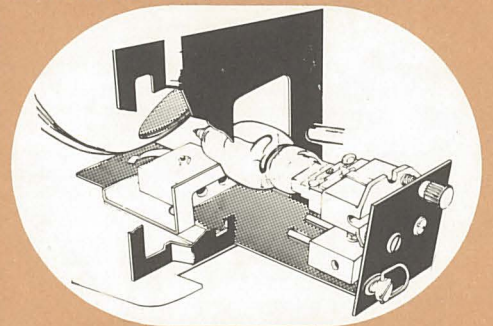

Unique 'plug-in' lamp tray with external 'flat/peak' trim control.

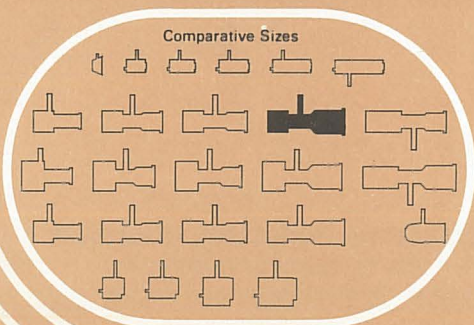

Comparative Sizes

Optional drop-in iris or iris/blackout assembly for follow spot conversion.

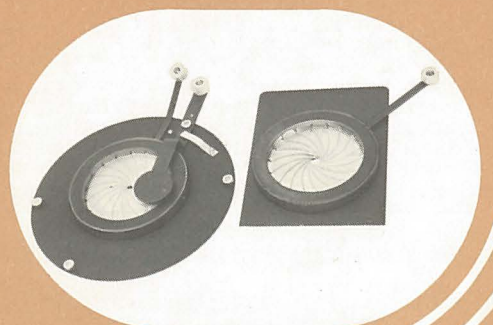

technical data

Order Code
Z00AS

Weight 16.7kg

Photometric Data

PEAK DISTRIBUTION

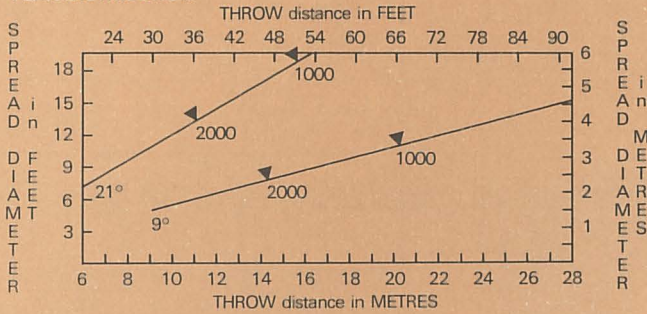

FLAT DISTRIBUTION

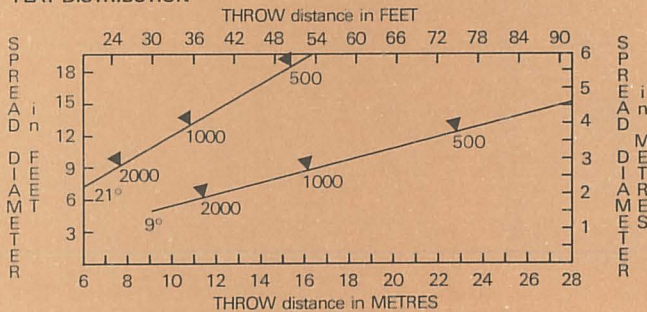

The figures on the diagonal lines indicate the maximum illumination value in LUX in the beam.

Specification

Lamphouse shall be constructed in aluminium alloy extrusions finned to ensure maximum heat dissipation, formed aluminium sheet and steel. The lampholder shall be mounted on a 'plug-in' lamp tray allowing inspection or change of lamp and cleaning with complete safety. External adjustment shall be provided for lamp trimming and 'peaky'/'flat' beam adjustment with the patented aspheric super pure aluminium reflector. Four individually tempered stainless steel beam shaping shutters shall be provided in a 'stand alone' gate assembly mounted between the lamphouse and lens tube to enable a sharp or soft edged cut-off as required. The gate shall accept drop-in iris and gobo holder. The heat resisting ring handles controlling shutter action shall be within the outer measurement of the lamphouse when fully closed so as to prevent damage in transit. A full width heat insulated handle shall be fitted to the rear of the lamphouse. The yoke shall be in 40mm x 5mm steel tapped for 12mm bolt. It shall be bolted to lamphouse via a heat insulated large diameter knob and friction locking disc forming part of the lamphouse. Yoke mounting system shall provide for alternative mounting on lamphouse or lens tube for balance adjustment when used with other lens tubes and for suspension clamp or stand. A heavy duty secondary support bracket is attached to side extrusion by high tensile bolt. The external 1.5m length 3 conductor high temperature cable shall be secured by a compression gland and terminate at an internal porcelain connector. The lens tube shall be in rolled steel bolted to lamphouse gate assembly. Triple aluminium extrusion colour frame runners shall be mounted on the front of the lens tube to accommodate a lens guard and two standard colour filter frames or a remote control semaphore or wheel colour change unit. The entire front colour magazine shall be bolted to the lens tube front and designed for field adjustment to provide top or side entry of colour frames. Lens control knobs shall be settable for top or bottom operation. The magazine shall have a spring safety retention clip. One folded book form zinc steel frame shall be supplied. There shall be two borosilicate lenses mounted independently in large aluminium castings moving in the tube each controlled by means of a palm grip heat insulated knob. The rear lens shall be 114mm x 165mm and the front lens shall be

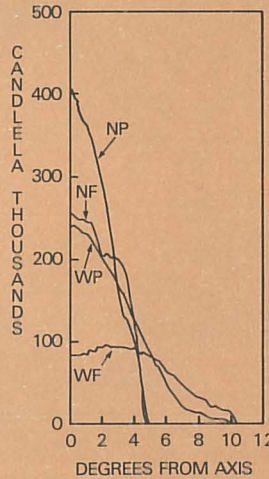
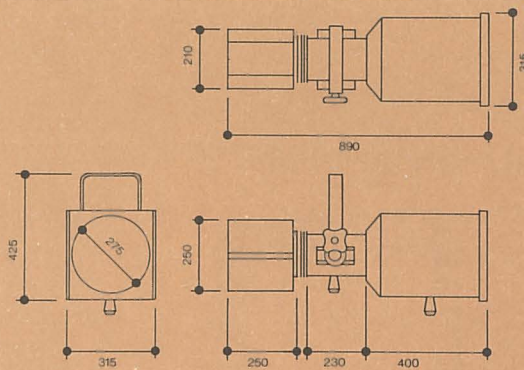

Typical performance based on calibrated 1000W 240V T19 lamp C13D biplane filament, 750 HOUR, 3050°K, 21,000 LUMEN.

HARD EDGE FOCUS

NARROWEST SPREAD CUT-OFF angle 9°

PEAK ADJUSTMENT 1/2 peak angle 5°
410,000 peak CANDELAS

FLAT ADJUSTMENT 1/2 peak angle 8°
260,000 peak CANDELAS

WIDEST SPREAD CUT-OFF angle 21°

PEAK ADJUSTMENT 1/2 peak angle 8°
244,000 peak CANDELAS

FLAT ADJUSTMENT 1/2 peak angle 13°
105,000 peak CANDELAS

Flat adjustment is defined as a 2:1 ratio within the beam.

254mm x 508mm. The front lens shall determine the beam angle while the rear lens shall be used to focus the spot to a soft or hard edge. Control knobs shall screw tight to the lens tube to secure the selected focus. A graduated scale shall be located parallel with the lens slide slot enabling settings to be recorded. The luminaire finish shall be electrostatically applied high temperature black epoxy paint with high resistance to chipping and marking.

Accessories

Z0017 Iris/Blackout Assembly

The addition of this assembly between the shutter set and lens tube converts the luminaire into a followspot. The blackout is normally activated automatically by the thumb at the end of the iris travel. Both levers are heat insulated and mounted below the lens housing for easy cool operation.

Z0016 Drop-in Iris

Z0015 Spare book form colour frames designed for easy waste-free filter cutting

Z0083 Hook Clamp

Z0085 Safety Chain

Z0021

Hand Operated Colour Change Unit
Coloursette 6 has a change facility for up to six colours, is easily reversible and can be operated from either side of the Spotlight.

Y0058 12mm Spigot

Y7501 Gobo Holder.

CCT theatre lighting limited

WINDSOR HOUSE 26 WILLOW LANE MITCHAM
SURREY CR4 4NA Tel 01-640 3366 Telex 946648