

# BAMBINO 5 kW

## Quartz Halogen Fresnel

Preliminary data sheet

- Improved light quality and output, producing a flatter and more even field
- High quality, rugged, durable
- Corrosion resistant for longer life
- Compatibility of parts throughout the range
- A comprehensive range of accessories, interchangeable with existing Quartzcolor products
- Easy to service and maintain
- Bonding eyes and rigging hooks
- Front and back focusing
- New worm drive mechanism for precise focusing
- New focus system, easy to adapt from manual to pole operation and maintenance free
- New easy running barndoors ears
- Scratch resistant black non-reflective housing
- CE mark, c UL us listed



### Operational data

**Safety:**  
25 x 25 mm wire mesh guard.

**Accessory fitting:**  
Die cast aluminium ears.  
Spring loaded top and lower catch for retention of accessories.

**Tilt adjustment:**  
Pivot located at centre of gravity for excellent balance and positive locking.

**Focus adjustment:**  
Front and rear focusing knobs (MO units) or side mechanism (PO units) for smooth and precise action from spot to flood positions

**Lamp access:**  
Hinged lens door allows easy access for lamp replacement.

### Weights & dimensions

<b>Lens diameter</b>	250 mm
<b>Accessory diameter</b>	325 mm
<b>Filter cut size</b>	320 x 320 mm
<b>Weight (head + stirrup) M.O.</b>	16 kg
<b>Weight (head + stirrup) P.O.</b>	19 kg
<b>Packed weight M.O.</b>	20 kg
<b>Packed weight P.O.</b>	23 kg
<b>Packed volume</b>	
M.O.	610 x 640 x 750 mm
P.O.	610 x 640 x 750 mm

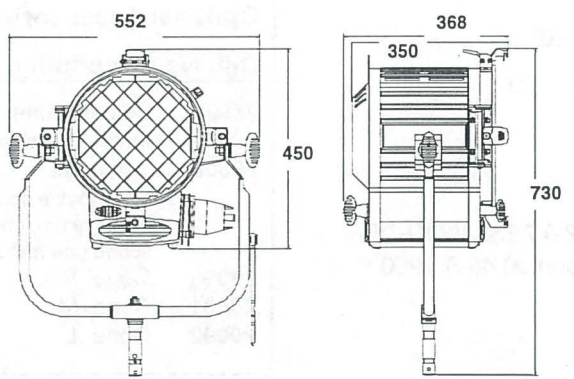

M.O.

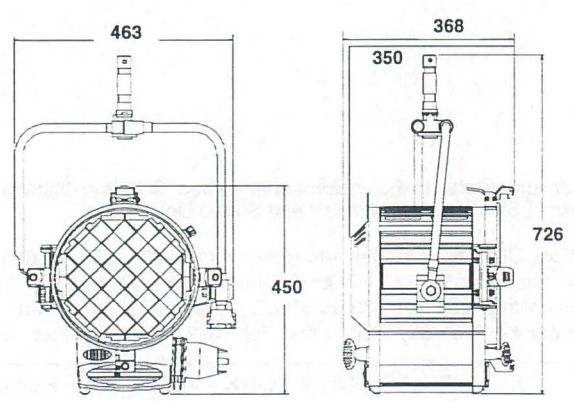

P.O.



**Photometric data**

Typical performance based on CP 29 - 5000 W lamp:

Throw [m]

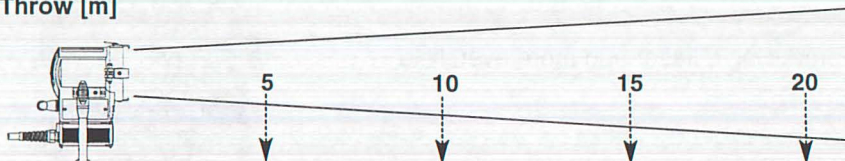

	Lux	φ [m]	Lux	φ [m]	Lux	φ [m]	Lux	φ [m]
<b>SPOT (14.5°)</b>	15,120	1.3	3,780	2.5	1,680	3.8	950	5
<b>FLOOD (60.3°)</b>	3,880	5.8	970	11.6	430	17.4	240	23.2

**Lamp data**

<b>Lamp code</b>	CP29 - 5000 W
<b>LCL (mm)</b>	165
<b>Base</b>	G38
<b>Lumens</b>	135000
<b>Rated life hours (H)</b>	500
<b>Colour temp. (K)</b>	3200

**Mechanical data**

- Paint / Finish:** Powder coated epoxy paint with special extra high temperature treatment in critical areas. External textured low gloss finish
- Lamp house** Die cast aluminium components, stainless steel housing
- Mounting:** Robust tubular MO or PO steel stirrup with EURO spigot

**Environmental Data**

- Max operating ambient temperature:** 45°C
- IP Rating:** IP 20
- Tilt recommended angle of use:** -60° / 0 / 60°

**Electrical data**

- Cable / Switching:** 7m 3x4 mm<sup>2</sup> with side mounted 32 A / 250 V ON-OFF toggle switch (MO) or with side mounted 45 A / 250 V ON-OFF rotary switch (PO)
- Standards compliance:** CE mark, c UL us listed

**Ordering information**

**Cat No Description**

- 27660 Bambino 5 kW M.O.** supplied with stirrup, colour frame, 4 leaf rotating barndoor
- 27662 Bambino 5 kW P.O.** supplied with P.O. stirrup, colour frame, 4 leaf rotating barndoor

**Optional Accessories**

**Cat. No Description**

- 28093** Colour frame
- 28070** 4 leaf barndoor
- 28306** Scrim set  
(one double scrim, one single scrim, one half double scrim, one half single scrim)
- 28090** Cone S
- 28091** Cone M
- 28092** Cone L

The Company reserves the right to make any variation in design or construction to the equipment described. © Strand Lighting Ltd 1999. Strand™, Strand Lighting™, Strand Quartzcolor™ are trade marks of Strand Lighting Limited and Strand Lighting Inc.

**Strand Lighting Ltd** North Hyde House Hayes Rd Heston Middx UB2 5NL UK Tel: +44 (0)181 571 3588 Fax: +44 (0)181 571 3305  
**Strand Lighting GmbH** Ullsteinstrasse 114-142 D-12109 Berlin Germany Tel: +49 (0) 30/70 79 51 0 Fax: +49 (0) 30/70 79 519 9  
**Strand Lighting Italia srl** Via delle Gardenie 33 00040 Pomezia-Roma Italy Tel: +39 06 91963.1 Fax: +39 06 9147136  
**Strand Lighting Asia Ltd** 7/F Corporation Square 8 Lam Lok Street Kowloon Bay Hong Kong Tel: +852 2757 3033 Fax: +852 2757 1767

LONDON - BERLIN - ROME - PARIS - MOSCOW - LOS ANGELES - NEW YORK - TORONTO - HONG KONG