



BAMBINO 10 kW

Quartz Halogen Fresnel

Preliminary data sheet

- Improved light quality and output, producing a flatter and more even field
- High quality, rugged, durable
- Corrosion resistant for longer life
- Compatibility of parts throughout the range
- A comprehensive range of accessories, interchangeable with existing Quartzcolor products
- Easy to service and maintain
- Bonding eyes and rigging hooks
- Front and back focusing
- New worm drive mechanism for precise focusing
- New focus system, easy to adapt from manual to pole operation and maintenance free
- Easy running adjustable bamdoors ears
- Scratch resistant black non-reflective housing
- CE mark, c UL us listed



Operational data

Safety:

25 x 25 mm wire mesh guard.

Accessory fitting:

Die cast aluminium ears.
Spring loaded top catch for retention of accessories.

Tilt adjustment:

Pivot located at centre of gravity for excellent balance and positive locking.

Focus adjustment:

Front and rear focusing knobs (MO units) or side mechanism (PO units) for smooth and precise action from spot to flood positions

Lamp access:

Hinged lens door allows easy access for lamp replacement.

Weights & dimensions

Lens diameter 350 mm
Accessory diameter 410 mm
Filter cut size 400x400 mm

Weight (head + stirrup) M.O. 28 kg
Weight (head + stirrup) P.O. 32 kg
Packed weight M.O. 32 kg
Packed weight P.O. 36 kg

Packed volume

M.O. 610 x 640 x 750 mm
P.O. 610 x 640 x 750 mm

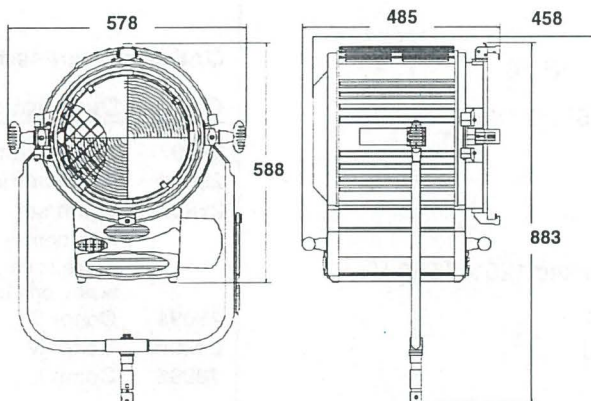

M.O.

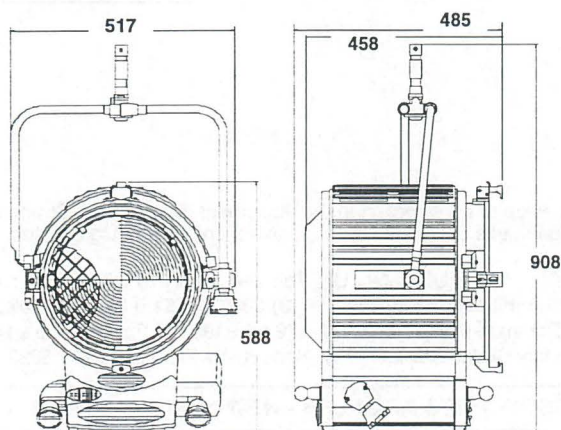

P.O.



Photometric data

Typical performance based on CP 83 - 10000 W lamp:

Throw [m]

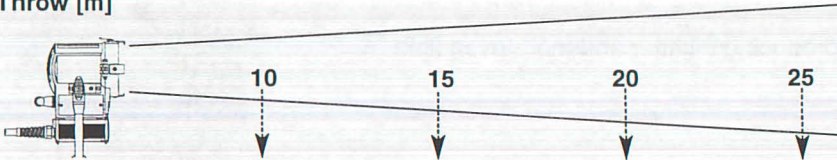

	Lux	φ [m]	Lux	φ [m]	Lux	φ [m]	Lux	φ [m]
SPOT (13.5°)	8,540	2.3	3,800	3.5	2,130	4.7	1,370	5.9
FLOOD (51.5°)	1,560	9.6	690	14.5	390	19.3	250	24

Lamp data

Lamp code	CP83 - 10000 W
LCL (mm)	254
Base	G38
Lumens	290000
Rated life hours (H)	500
Colour temp. (K)	3200

Mechanical data

- Paint / Finish:** Powder coated epoxy paint with special extra high temperature treatment in critical areas. External textured low gloss finish
- Lamp house** Die cast aluminium components, stainless steel housing
- Mounting:** Robust tubular MO or PO steel stirrup with EURO spigot

Environmental Data

- Max operating ambient temperature:** 45°C
- IP Rating:** IP 20
- Tilt recommended angle of use:** -45° / 0 / 45°

Electrical data

- Cable / Switching:** 7 m 3x10 mm² with side mounted 125 A / 250 V ON-OFF rotary switch
- Standards compliance:** CE mark, c UL us listed

Ordering information

Cat No Description

- 27680 Bambino 10 kW M.O.** supplied with stirrup, colour frame, 4 leaf rotating barndoor
- 27682 Bambino 10 kW P.O.** supplied with P.O.stirrup, colour frame, 4 leaf rotating barndoor

Optional Accessories

Cat. No Description

- 28097** Colour frame
- 28074** 4 leaf barndoor
- 28307** Scrim set
(one double scrim, one single scrim, one half double scrim, one half single scrim)
- 28094** Cone S
- 28095** Cone M
- 28096** Cone L

The Company reserves the right to make any variation in design or construction to the equipment described. © Strand Lighting Ltd 1999. Strand™, Strand Lighting™, Strand Quartzcolor™ are trade marks of Strand Lighting Limited and Strand Lighting Inc.

Strand Lighting Ltd North Hyde House Hayes Rd Heston Middx UB2 5NL UK Tel: +44 (0)181 571 3588 Fax: +44 (0)181 571 3305
Strand Lighting GmbH Ullsteinstrasse 114-142 D-12109 Berlin Germany Tel: +49 (0) 30/70 79 51 0 Fax: +49 (0) 30/70 79 519 9
Strand Lighting Italia srl Via delle Gardenie 33 00040 Pomezia-Roma Italy Tel: +39 06 91963.1 Fax: +39 06 9147136
Strand Lighting Asia Ltd 7/F Corporation Square 8 Lam Lok Street Kowloon Bay Hong Kong Tel: +852 2757 3033 Fax: +852 2757 1767

LONDON - BERLIN - ROME - PARIS - MOSCOW - LOS ANGELES - NEW YORK - TORONTO - HONG KONG