

SELECON

PRODUCT DATA SHEET



FLOOD

The Acclaim Flood provides a 90 degrees even wash of light for stage colour washes and display lighting. 200 – 500W. Supplied with four masking barndoors to shape the beam.

Constructed of Injection moulded Rynite plastic and aluminium extrusion. The Acclaim Flood offers efficiency, strength and performance.



FEATURES

- Smooth, well controlled beam.
- Dual chamber airflow maximises colour filter life.
- 4 Barndoor flaps provided to shape the beam.
- Dismountable colour filter holder. The filter clamp frame doubles as a template to cut the filter to the right size.
- Constructed from aluminium extrusion and plastic injection moulding.
- Can be assembled into multi battens as for the Cyc range.
- Easy and safe access for relamping and cleaning with hinged safety glass that disconnects the mains supply when opened.
- Fully tested and compliant to CE standards.

PHOTOMETRIC DATA

Tests conducted using a standard R7 118mm double-

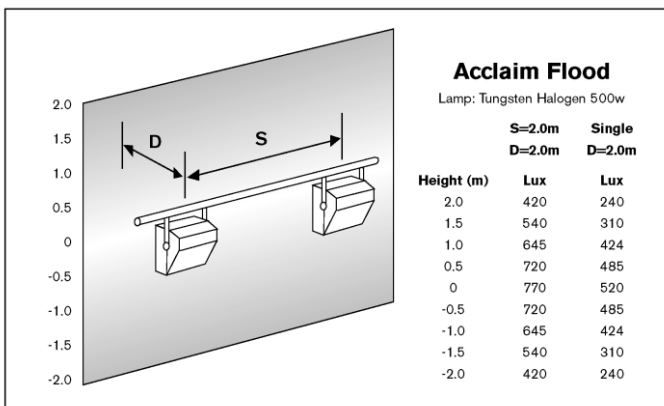

ended linear, 500W, 240V lamp.

PHYSICAL DATA

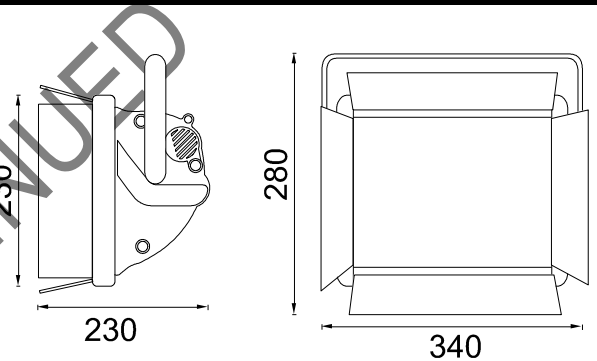

	Single	3 way	4 way
Weight:	2.8 Kg	8.5Kg	11.5Kg
Colour Frame Size:	230mm x 204mm		
Included:	1 x colour cassette and frame, 1 x M10 suspension bolt set & instruction leaflet.		

ORDER CODES & ACCESSORIES

Acclaim Flood	12ACFLOOD
Acclaim Flood 3 way	12ACFLOOD3
Acclaim Flood 4 way	12ACFLOOD4
Spare Colour Cassette with Flaps	SAA-AFHWD
Spare Colour Frame	SAA-AFSC
Suspension Hook Clam	20HC
Safety Bond	20SC

LAMPS

220-240V	500W	K1	9,900 lumens	2000hrs average life
220-240V	300W	K9	5,600 lumens	2000hrs average life
220-240V	200W	K11	3,520 lumens	2000hrs average life

Selecon reserves the right to change the specifications without notice (10/03)

SELECON, THE ONLY MANUFACTURER TO OFFER A LIMITED THREE YEAR WARRANTY ON ENTERTAINMENT PRODUCTS

www.seleconlight.com/english/support/warranty.html