



SL15/32, SL23/50

Coolbeam zoom spotlights 600W

Features

Excellent light output, superb distribution and the smoothest soft edge while maintaining beam size. Sharp gobo, edge and shutter focus. Very compact and narrow with the smallest dimensions in their category. Easy to use and maintain with many features for increased safety.

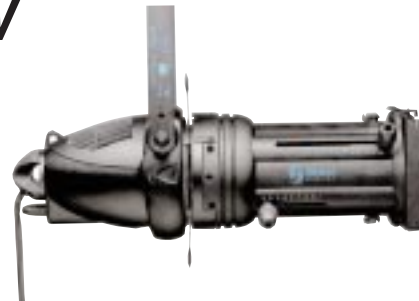

- ❑ Precision optical system with high light output
- ❑ High efficiency dichroic glass reflector and coated aspheric computer-designed lenses
- ❑ Coolbeam operation for extended gobo, shutter and gel life
- ❑ Optimised for energy efficient, high performance GKV 600W lamps; GLB long life lamps also available
- ❑ Consumes significantly less energy while providing more light than most conventional 1000W/1200W spotlights
- ❑ Fast and easy lamp centring with positive screw driver lock so that it won't move in transit
- ❑ Fast positive peak/flat adjustment via lead screw drive mechanism for smooth, tool-free field settings
- ❑ Bayonet action lamp changing system for simple lamp changes without affecting field setting
- ❑ Compact and lightweight, allowing closer hanging in tighter spaces
- ❑ Smooth 360° body rotation for quick and easy gobo and shutter positioning
- ❑ Shutters in three planes for triangular shutter cut
- ❑ Highly versatile rigging by combining 360° rotation with two balance positions for yoke
- ❑ Large rear handle for easy positioning
- ❑ Quick and easy access for reflector and lens cleaning
- ❑ Common lamp house with easily interchangeable tubes
- ❑ Wide gate will fit 2 gobo holders, including glass gobo holder, drop-in iris or rotating gobo holder
- ❑ Safety bond attachment point for the luminaire and accessories
- ❑ CE marking

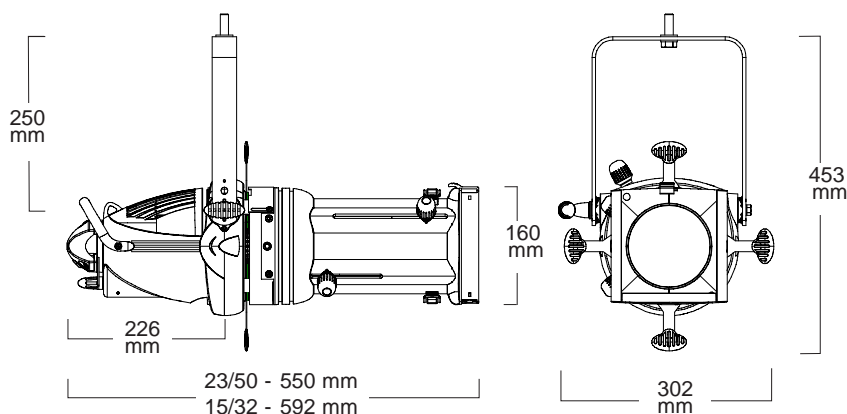

Weights and dimensions

	15/32	23/50
Weight	7 kg	6.9 kg
Packed weight	9.8 kg	9.6 kg
Packed volume	0.083m ³	0.08m ³
Filter cut size	158 x 158 mm	



Photometric data

Typical performance based on: 600w GKV 230/240V lamp

SL15/32

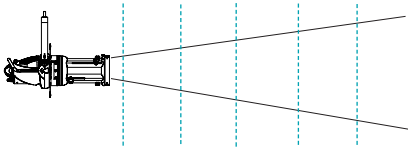

SL15/32 at 15°

Distance (m)	5	10	15	20	25
Beam Ø (m)	1.3	2.6	3.9	5.3	6.6
Illum (lux)	6160	1540	684	385	246

Beam candle power (cd) 154,000

SL15/32 at 26°

Distance (m)	5	10	15	20	25
Beam Ø (m)	2.3	4.6	6.9	9.2	11.5
Illum (lux)	4880	1220	542	305	195

Beam candle power (cd) 122,000

SL15/32 at 32°

Distance (m)	5	10	15	20	25
Beam Ø (m)	2.9	5.7	8.6	11.5	14.3
Illum (lux)	3280	820	364	205	131

Beam candle power (cd) 82,000

SL23/50

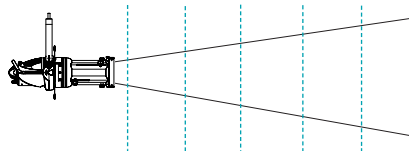

SL23/50 at 23°

Distance (m)	5	10	15	20	25
Beam Ø (m)	2.0	4.1	6.1	8.1	10.2
Illum (lux)	4640	1160	516	290	186

Beam candle power (cd) 116,000

SL23/50 at 35°

Distance (m)	5	10	15	20	25
Beam Ø (m)	3.2	6.3	9.5	12.6	15.8
Illum (lux)	2000	500	222	125	80

Beam candle power (cd) 50,000

SL23/50 at 50°

Distance (m)	5	10	15	20	25
Beam Ø (m)	4.7	9.3	14.0	18.7	23.3
Illum (lux)	1200	300	133	75	48

Beam candle power (cd) 30,000

Performance at any distance: divide beam candle power by distance²

For beam diameter at any distance:	15° multiply 0.26 x distance	23° multiply 0.41 x distance
	26° multiply 0.46 x distance	35° multiply 0.63 x distance
	32° multiply 0.57 x distance	50° multiply 0.93 x distance

Electrical & mechanical data

Construction

Die cast aluminium housing with black epoxy powder coat. Stainless steel shutters.

Gate

Plated steel

Lenses

Crown glass coated aspheric lens

Lamp

G9.5 base

GKV 400 hours 3200° K

GLB 1500 hours 3100° K

Supply voltage

120-240V, 50/60 Hz

Standards compliance

CE marking

Max operating ambient temperature

45°C

The Company reserves the right to make any variation in design or construction to the equipment described. © Strand Lighting Ltd 1999.

Strand™, Strand Lighting™, Strand Quartzcolor™ are trade marks of Strand Lighting Limited and Strand Lighting Inc.

Ordering information

SL 15/32 and 23/50 are supplied with 360° rotation mounting yoke, colour frame, GKV 600W lamp, 1.0m of power cable fitted with 15 amp or Schuko plug. A bare end version is also available without lamp and plug.

Cat No Description

11410	15/32 SL, 230/240V, 600W, BE
11413	15/32SL, 230/240V, 600W, Schuko plug
11414	15/32SL, 230/240V, 600W, 15amp plug
11420	23/50 SL, 230/240V, 600W, BE
11423	23/50SL, 230/240V, 600W, Schuko plug
11424	23/50SL, 230/240V, 600W, 15amp plug

Optional accessories

18045	Gobo holder size B
18049	Iris (24 leaf)
18114	Colour frame
18115	High hat
18143	Donut

Strand Lighting Ltd North Hyde House Hayes Rd Heston Middx UB2 5NL UK Tel: +44 (0)181 571 3588 Fax: +44 (0)181 571 3305
Strand Lighting GmbH Ullsteinstrasse 114-142 D-12109 Berlin Germany Tel: +49 (0) 30/70 79 51 0 Fax: +49 (0) 30/70 79 519 9
Strand Lighting Italia srl Via delle Gardenie 33 00040 Pomezia-Roma Italy Tel: +39 06 919631 Fax: +39 06 9147136
Strand Lighting Asia Ltd 7/F Corporation Square 8 Lam Lok Street Kowloon Bay Hong Kong Tel: +852 2757 3033 Fax: +852 2757 1767

LONDON - BERLIN - ROME - PARIS - MOSCOW - LOS ANGELES - NEW YORK - TORONTO - HONG KONG