

## GENERAL INFORMATION

Full-featured console for control of conventional and moving lights, media servers and LEDs with 40 hands-on multipurpose masters, 40 direct selects, preset operation, theatrical-style crossfader playback and full network capabilities.

### APPLICATIONS

- Theatre
- Television Studios
- Houses of Worship
- Touring
- Concerts
- Corporate Theatre
- Special Events

### FEATURES

- 6144 Outputs/Parameters (12 Universes of DMX512A)
- 3072 Control Channels
- Main Playback crossfader pair for theatrical-style sequence with split spring-loaded rate controls
- 40 Multipurpose Masters with graphical LCD displays (999 Pages)
- 40 Direct Selects with graphical LCD displays
- 4 Encoders and ML Display
- High-density channel display with Formats for channel sorting
- Channel Layouts for topographical views of channels
- Live Attributes display for spreadsheet view of moving lights
- List Views and Editors for Presets, Groups, Palettes, Sequences
- Dynamic Effects
- Integrated Electronic Manual and Help system
- Mouseless navigation of tabbed graphical displays
- Integral alpha keyboard for labeling
- MIDI In/Out
- Audio In/Out
- ETCNet2, Net3/ACN, Avab IPX, ArtNet Ethernet protocols
- Show import via ASCII (Avab Safari, Expert, Pronto, Presto, ETC Expression, Express, Strand 500)

## ORDERING INFORMATION

### Congo

MODEL	DESCRIPTION
CGO	Congo Console, 1024 Outputs
CGO256	Congo Output Upgrade, 256 Outputs
CGOCL	Congo Client Software Kit

\*Important Congo Ordering Information:

Congo is offered as a base console with 3072 control channels and 1024 outputs (2 universes of DMX512). A single control channel may control only intensity (dimmers) or it may control a DMX controlled device (moving light, media server, etc).

To increase the capacity of the console, order additional 256-output upgrades.

For example, to take the console to its maximum configuration, order a console and twenty (20) 256-output upgrades.

1024 outputs + (20x256) = 6144 outputs (12 universes of DMX512)

Two universes are available at the console via 5-Pin XLR, or all universes may be distributed via ETCNet2 DMX nodes (purchased separately).

### Congo Accessories

MODEL	DESCRIPTION
RRFU-CGO	Radio Remote Focus Unit (Congo)
CGO Littlite	Congo Littlite(R) Worklights
CGOMA	Monitor Arms for 15" LCD Displays with VESA mount*
CGO Flightcase	Congo Flightcase

\*Not all monitors fit these arms. Arms are designed to support 15" LCD displays with either the 75mm or 100mm VESA mounting holes in a generally central position on the back of the monitor. Monitors with additional speakers or VESA mounts located near the top of the monitor may not be suitable for use with these arms.

Congo Offline Editor software is available for download from [www.etcconnect.com](http://www.etcconnect.com)

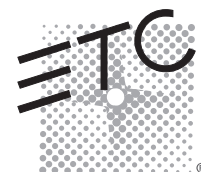

## SPECIFICATIONS

## SYSTEM CAPACITY

- 6144 Outputs/parameters
- 3072 Control Channels
- 9999 Presets
- 4x 999 Palettes (Focus, Color, Beam, All)
- 999 Groups
- 999 Macros
- 999 Sequences
- 999 Master Pages
- 999 Dynamic Effects Templates
- Supports three VGA monitors starting at 1024x768 resolution
- Hard Disk
- USB ports for USB Flash drive, floppy drives, pointing devices, keyboards

## DISPLAY FUNCTIONS

- Tabbed, mouseless navigation of graphical screens
- All show data may be viewed on a single monitor
- Tab layouts may be recorded to direct selects for quick recall
- Browser
  - File Management
  - Show Data lists
  - Patch Displays and functions
  - Help
  - Images
  - Movies
- Channel Displays
  - Live, Blind, Preset, Sequence and Group Editors
  - High-density views of channel data
  - Format allows user to choose a packed,
  - Flexichannel-style view of channels
  - Zoom allows user to define how many channels are viewed
  - Current direction of fade and preview of next intensity move
  - Color coded intensity levels indicate HTP winner
  - FCB indicators of changed or moving data
  - Channel number color indicates intensity only or moving light
- Channel Layouts
  - 999 Channel Layouts
  - User-defined topographical view of channels
  - May include other types of data – Presets, Palettes, Groups, etc.
  - Auto-selectable (visible layout changes based on channel selection)
- Attribute Displays
  - Live Attributes with Formats to display current rig status
  - Parameters may be edited directly in the Live Attributes tab
  - Attribute views in editors for viewing and editing parameter and time/delay data
- List Views
  - High-density view of recorded data
  - Group, Focus Palettes, Color Palettes, Beam Palettes, All Palettes, Preset, Sequence, Dynamic Effects, Master Page List views
  - Apply text labels to show data
  - Access Editor displays from within list views

## SPECIFICATIONS

- Editor Views
  - View and edit show data within editor views
  - Group, Focus Palettes, Color Palettes, Beam Palettes, All Palettes, Preset, Sequence,
  - Dynamic Effects, Master Page, Template Editor views
  - Multiple editor views may be open at the same time
- Patch Views
  - Channel List
  - Output List
  - Device List
  - Channel Database for applying up to four labels to each channel
  - Patch Wizard for clearing patch, range patching and moving light 'next available' patching
- Playback Views
  - Main Playback view
  - Connected Master Playback view
  - Timeline view of current crossfade progress and preview of next crossfade

## PLAYBACK CONTROLS

- Main Playback crossfader pair for theatrical-style sequence with split spring-loaded rate controls
- Master Playback for connection to sequences on the multipurpose Masters
- Manual or timed fade control
- 999 Sequences (standard mode triggered by
- "Go" or chaser mode)
- Grandmaster fader
- Blackout/On/Freeze rotary switch

## MASTERS SECTION

- 40 Multipurpose Masters with graphical LCD displays
- Bottom 20 Masters with Bump and Master keys with LED indicators
- Top 20 Masters with Master keys with LED indicators
- 999 Master Pages
- Masters may be independently paged in banks of 20 faders (top/bottom)
- Page +, Page – and direct Page keys for each bank of Masters
- Channels Only/Masters/Jam Mode rotary switch

## SPECIFICATIONS

**MOVING LIGHT SECTION**

- 4 Encoders with keys
- ML Display, 240x128 resolution
- Focus, Color and Beam encoder pages
- User-defined encoder pages
- 40 Direct Selects with graphical LCD displays
- Highlight, Fan and Mask
- Dynamic group selection

**INDEPENDENT SECTION**

- 6 Rotary faders
- 3 Switches with LED indicators
- May contain any channel data, including ML attributes
- Switches may be assigned latch or momentary operation
- All may be assigned inclusive, inhibitive or exclusive operation

**PROGRAMMING PAD FEATURES**

- Channel Functions
  - Selection lists constructed with Chan/ID, +, -, Thru
  - Levels set with Level Wheel or @ Level key
  - Assign Palettes and Dynamic Effects quickly
  - Assign channels to Masters
- Preset Functions
  - Record and Update
  - Apply Timing
  - Fetch and Select data based on recorded Presets
  - Assign Presets to Masters
  - Sequence Functions
    - Create and Assign Sequences to the Main Playback and Masters
    - Insert and Edit Steps
    - Apply Step Timing
- Group Functions
  - Create and Edit Groups
  - Assign Groups to Masters
- Palette Functions
  - Create and Edit Palettes
  - Assign Palettes to Masters
- Dynamic Effects Functions
  - Create and Edit Dynamic Effect Templates
  - Assign Dynamic Effects to channels
  - Modify running Dynamic Effects
  - Insert running Dynamic Effects into the library
  - Assign Dynamic Effects to Masters
- Electronic Manual and Help System
  - Create and store synonyms
  - Add notes/comments to electronic manual
  - Create Favorites

## SPECIFICATIONS

**INTERFACES**

- 2 DMX512 Ports (RDM Ready)
- Ethernet (ETCNet2, Net3/ACN, Avab IPX, ArtNet)
- Contact closure triggers through D-Sub connector
- APN Connector (Avab Peripheral Network)
- USB multipurpose bus (4 ports)
- Remote Focus Unit (Radio RFU)
- Phone Remote
- MIDI In/Out (Input: MIDI, MIDI Timecode, MIDI Show Control; Output: MIDI)
- Audio In/Out

PHYSICAL

Product Dimensions

MODEL	HEIGHT		WIDTH		DEPTH	
	inches	mm	inches	mm	inches	mm
CONGO	6.5	165	44.7	1135	25	634

Product Weights\*

MODEL	WEIGHT		SHIPPING WEIGHT	
	lbs	kgs	lbs	kgs
CONGO	81.5	37	132.25	60

\*Weights and dimensions typical. Congo is shipped in a carton on a pallet. The shipping weight is the combined weight of the console on the pallet.

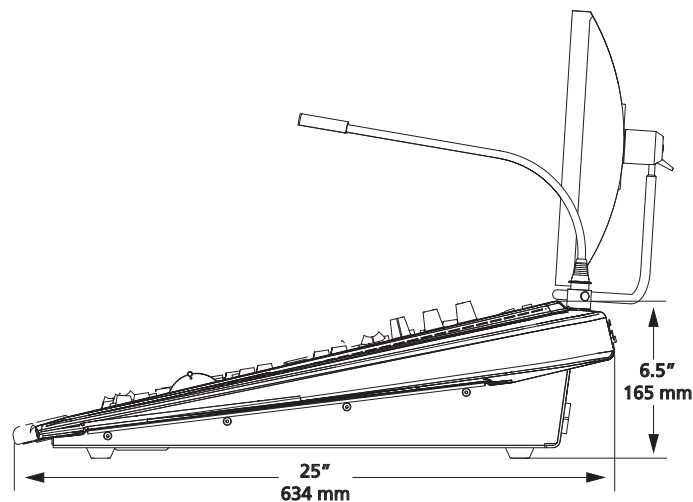
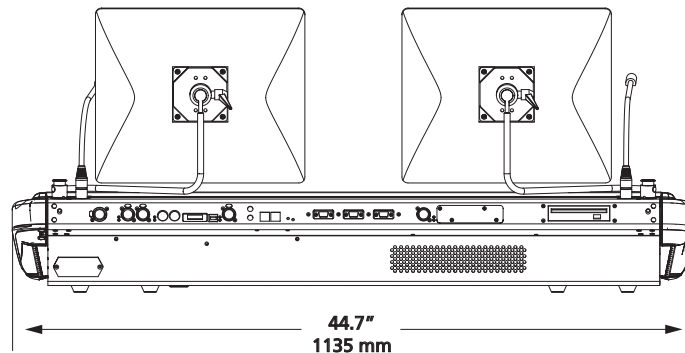

Corporate Headquarters • 3031 Pleasant View Rd, PO Box 620979, Middleton WI 53562 0979 USA • Tel +1 608 831 4116 • Fax +1 608 836 1736  
 London, UK • Unit 26-28, Victoria Industrial Estate, Victoria Road, London W3 6UU, UK • Tel +44 (0)20 8896 1000 • Fax +44 (0)20 8896 2000  
 Rome, IT • Via Ennio Quirino Visconti, 11, 00193 Rome, Italy • Tel +39 (06) 32 111 683 • Fax +39 (06) 32 656 990  
 Holzkirchen, DE • Ohmstrasse 3, 83607 Holzkirchen, Germany • Tel +49 (80 24) 47 00-0 • Fax +49 (80 24) 47 00-3 00  
 Hong Kong • Room 1801, 18/F, Tower 1 Phase 1, Enterprise Square, 9 Sheung Yuet Road, Kowloon Bay, Kowloon, Hong Kong • Tel +852 2799 1220 • Fax +852 2799 9325  
 Web • www.etcconnect.com • Copyright©2007 ETC. All Rights Reserved. All product information and specifications subject to change. 7310L1003 Rev. C Printed in USA 04/07