



# Strand Lighting

## P R O D U C T D A T A

### A Guide to Outlook

Outlook is a comprehensive family of control stations designed for architectural applications where a simple, flexible control solution with minimal installation and cabling cost is needed. Outlook is specifically designed for use with Strand Lighting Digital Environ, System 6, LD90, EC90SV and CD80SV dimmer cabinets.

The control stations access, modify and recall lighting levels stored in the dimmer cabinets via a common digital communication network cable without the need for an external central processor.

Control stations are available in various configurations and can be used in any combination to suit the user's requirements. During installation, an internal 16 position switch on the station determines the room to be controlled. Each of the possible 16 rooms can have up to 12 channels of control and 8 preset lighting scenes in addition to On and Off functions.

### Outlook Typical Schematic

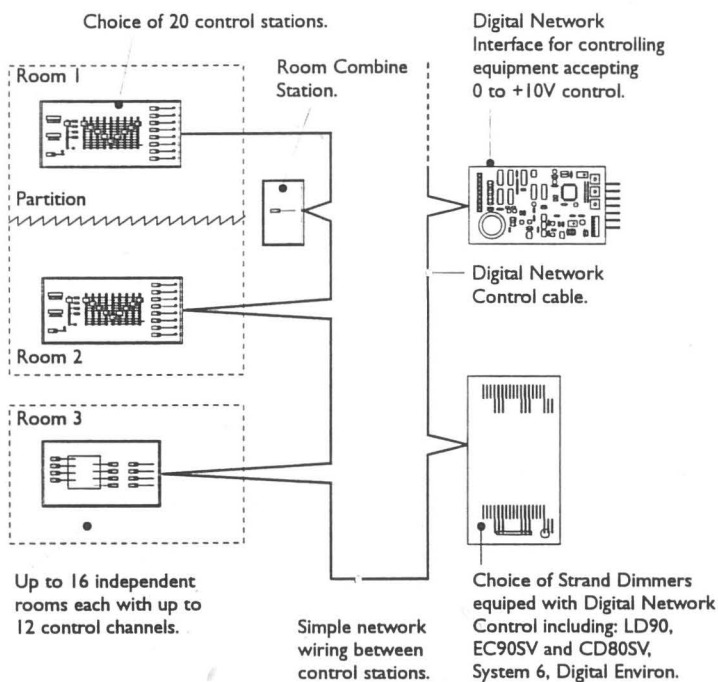

# 6.1.1

## ARCHITECTURAL

# OUTLOOK™

## Manual & Preset

### Lighting Control

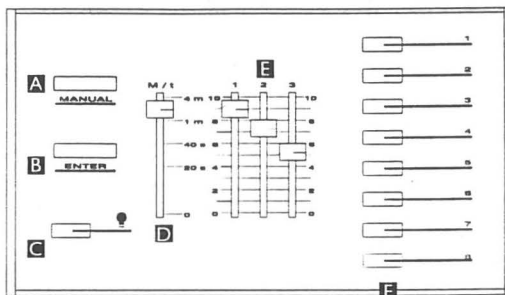

### Outlook Master Station

- A Manual - Activates local sliders.
- B Enter - Records slider settings into a preset.
- C Off - Selects black-out.
- D Master Slider - Overall control of slider levels and for setting fade times.
- E Channel Sliders - Individual control of lighting levels.
- F Preset Pushbuttons - For recall of 8 preset lighting scenes with fade times.

Typical applications include:

Conference and Meeting Rooms, Churches, Restaurants, Reception Areas and all small or medium sized applications.

- Comprehensive range of control stations
- Elegant screwless face plates with concealed fasteners
- Simple network control wiring
- Each system can control up to 16 rooms
- 8 Preset scenes plus On and Off per room
- Manual sliders for direct control of individual circuits
- Choice of 3, 6, 9 or 12 control channels per room
- Record facility to store slider settings for future pushbutton recall
- LCD Display Station for custom preset labels
- 1, 4 and 8 Preset Remote Pushbutton station options
- Audio Visual Interface and Infra Red Remote Controls
- Programmable fade times of between 0 and 4 minutes
- Record Lockout facility for playback-only operation
- Room Combine Stations for room partitioning
- Portable station options
- Designed for use with Digital Environ, System 6, LD90, EC90SV and CD80SV dimmers
- Digital Network Interface available for using Outlook with other dimmers

## Outlook™ Control Stations

## Master Stations

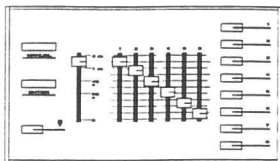

The Master Station is the most versatile station in the Outlook range combining the benefits of both preset and slider control. Master Stations have 3, 6, 9 or 12 sliders plus proportional master, activated by a Manual button, providing full control of the lighting.

8 Preset pushbuttons enable the recall of 8 presets with programmable fade times up to 4 minutes. There is also the provision of an Off button.

An Enter button enables the slider settings and fade time to be recorded into a preset.

Master Stations provide the following additional functions:

- Record Lockout - to prevent unauthorized modification of presets from the local station.
- Total Lockout - for disabling all other stations in the same room except the local station to prevent changes to the lighting.
- Preset Mastering - to proportionally master the level of a selected preset.
- Manual Fade Time - programmed for each room. When selecting Manual, the lighting fades to the levels set on the local sliders.
- Record Blind - to set up and record a preset lighting state from the manual slider settings without modifying the current lighting levels.

## Outlook Display Station

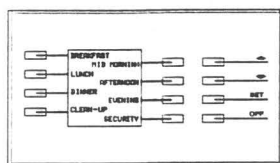

The Outlook Display Station has a 16 line, 16 character backlit LCD display used for labelling adjacent pushbutton functions.

The station has a "Set-up" or "Configuration" menu for selecting one of two\* modes of operation during installation:

## 1. Preset recall

Pushbuttons enable the recall of 8 labelled presets with programmed fade times. Raise and Lower buttons provide proportional mastering of the current preset, and an Off button fades lights off.

In this mode of operation, the Display Station provides the following additional functions:

- Custom label editing - 11 character labels for presets and 9 character labels for channels can be locally programmed.
- Channel level control - channel levels can be modified prior to recording a preset.
- Fade time programming - a fade time up to 4 minutes can be programmed for each preset.
- Record Lockout - to prevent local unauthorised modification of presets.
- Total Lockout - for disabling all other stations within the same room to prevent changes to the lighting.
- Clone - for copying labels to other Display Station in the same room to minimise programming.

## 2. Room Combination

Pushbuttons with custom room labels enable the user to combine, cancel and preview room combinations. Up and Down scroll buttons allow up to 16 rooms to be accessed.

In this mode of operation, the Display Station provides the following additional functions:

- Custom label editing - 11 character labels for rooms can be locally programmed.
- Clone - for copying room labels to other Display Station in this mode of operation to minimise programming.

A third operational mode configures the station for "System Wide Control" operation. Refer to the "System Wide Control" Datasheet for further information.

## Remote Preset Stations

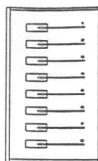

Preset Stations are available in versions with 1, 4 or 8 preset pushbuttons, for simple recall of pre-programmed lighting scenes within a room. Each pushbutton can be toggled to fade between its preset and Off.

## Slider Stations

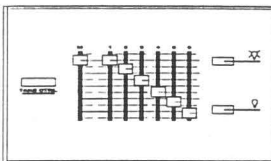

Slider Stations allow manual control of 3, 6, 9 or 12 channels with Manual ("take control") function to allow control to be switched from one slider station to another within a room. These stations also feature On and Off buttons for switching lights instantly to full or fading lights off respectively.

## Receptacle Station



The Receptacle Station provides a socket to connect a portable Master, Remote Preset, or Slider Station to the communications network.

## Audio Visual Interface

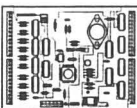

The A/V interface allows lighting presets to be selected automatically from external equipment such as slide projector controls, and sound systems. Each A/V Interface has 10 inputs with mimic outputs that accept a momentary contact closure to select one of the 8 presets, Off or On.

An additional input accepts a maintained contact closure to select the Total Lockout function (used to temporarily disable control from other stations within the room).

The A/V Interface is supplied as a printed circuit board to embody in equipment enclosures or with custom control panels. An external 18-24 volt dc power supply is required for the A/V Interface.

## Infra-Red Remote Controls



Infra-Red Remote Control provides the facility to control lighting from any position within a room up to 50ft (15m) from a Receiver Station. The hand held control unit has 8 pushbuttons for selection of presets 1 - 7 and Off.

## Outlook™ Control Stations

### Digital Network Interface

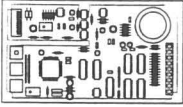

The Digital Network Interface enables the Outlook range of control stations to be used with dimming systems that do not directly support Outlook's Digital Network Control protocol. Each interface provides the necessary support for Outlook stations and so may be used for stand alone operation. The interface provides 6 analog 0 to +10 volt dc outputs for controlling external equipment. Refer to the "Outlook Digital Network Interface" Data Sheet for further details and a full specification.

### Room Combination

Function suites in Hotels and Conference Centers often have the requirement to partition the space to create different combinations of rooms. For lighting control to accommodate partitioning of the space and provide both separate room control and control of combined areas, a Room Combine Station or Interface is also required. Refer also to the "Display Station" which can be used for room combination.

### Room Combine Interface

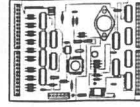

The Room Combine Interface is supplied as a printed circuit board which can be used either:

1. With partition switches, to automatically combine rooms when partitions are moved.
  2. With a custom control and mimic panel for manually selecting, cancelling and previewing multiple combinations of rooms.
- An external 18-24 volt dc power supply is required for the Room Combine Interface.

### Room Combine Stations

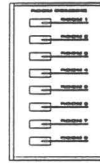

Room Combine Stations for 2, 3 or 8 rooms, allow the user to combine, cancel and preview a combination.

## Dimming Options and Configuration with Outlook

### Lighting Loads

Outlook Control Stations are designed for use with Digital Environ, System 6, LD90, EC90SV and CD80SV dimmer cabinets which have the capability of providing intensity control for tungsten, tungsten halogen, low voltage (transformer fed), fluorescent, neon and cold cathode lighting loads. Dimmers should be selected appropriate to the type of light source, load rating and the installation requirements. Alternative dimmers may be controlled from Outlook via the Digital Network Interface.

Strand Lighting Fact Sheets available include: "A Guide to Fluorescent Dimming" and "Dimming Transformer Fed Loads".

Note : System 6, Digital Environ and CD80SV are designed to North American standards, LD90 and EC90SV are designed to European standards.

### Digital Environ, LD90, EC90SV and CD80SV Dimmers

Using the dimmer cabinet keypad and display during set-up, each individual dimmer circuit is assigned to a control channel in one of the possible 16 rooms.

A Power Supply (Part No. 66100 or 66101) is required when using Outlook control stations with LD90 dimmers.

Power supplies 76462 and 76421 are required when using Outlook control stations with CD80SV and EC90SV respectively.

Digital Environ has a power supply for up to 20 Outlook stations fitted as standard. The System 6 range includes cabinets with a power supply for 20 Outlook stations.

### Digital Network Interface and System 6 Dimmers

The Digital Network Interface and System 6 dimmers are configured during installation and commissioning using three rotary switches which set the following:

- 1 A room number (in the range 1 - 9)
- 2 A channel number (corresponding to the first dimmer in the cabinet, or first interface output)
- 3 The option of splitting the cabinet / interface into two consecutive rooms with three channels in each.

#### Example A: A single 12 channel room.

Two 6 way cabinets or two interfaces would be used and assigned as follows:

Cabinet or Interface 1

- Room 1, Channel 1 (assigns dimmers to channels 1 - 6), un-split.

Cabinet or Interface 2

- Room 1, Channel 7 (assigns dimmers to channels 7 - 12), un-split.

#### Example B: Two rooms with 9 and 3 channels respectively.

Two System 6 Cabinets or two interfaces would be used and assigned as follows:

Cabinet or Interface 1

- Room 1, Channel 1 (assigns dimmers to channels 1 - 6), un split.

Cabinet or Interface 2

- Room 1, Channel 7, Split.

(assigns the first three channels to room 1, channels 7 - 9. The Split function allocates the remaining channels to the next room in sequence ie Room 2, channels 1 - 3).

## Outlook™ Specifications

### GENERAL

1 Outlook shall be a microprocessor based control system, utilizing digital communications between the control stations, dimmers supporting the Digital Network protocol, or Digital Network Interface (DN Interface) card.

2 The control station face plates shall be free of visible fasteners and shall be of aesthetic appearance.

3 Station faceplates shall be fabricated from 0.025" (0.64mm) aluminum with a die cast trim frame and shall be supplied in an off-white finish with legends printed in grey.

4 Control stations shall require US flush mounted masonry back boxes. Raco Series 690/960 or approved equal are recommended, and can be supplied to order.

Note: Back boxes must be grounded/earthed in accordance with local wiring practice to provide a discharge path to ground for static electricity.

5 Control station sliders shall have a 1.75" (45mm) travel with grey slider knobs.

Control station pushbuttons shall have grey button caps with integral red LED indicators. It shall not be necessary to remove button caps or sliders knobs, or to disassemble the control station for installation.

6 Control stations shall be supplied complete with a sub-plate which is screwed to the flush mounting back box with the screws provided. The sub-plate allows the control station to be hinged into position and secured with hexagonal set screws on the bottom edge of the trim ring. A 1/16" (1.6mm) Allen key shall be provided with each station.

7 All control cable terminations shall be via screw terminal plug and socket to facilitate removal of the station while maintaining continuity of the data highway.

8 All stations require a 24 volt dc supply (nominally 100mA per station) from a remote power supply.

9 A 16 position rotary switch shall be provided on the back of each station for room selection.

Station switch positions 1-9, A-F and 0 (total 16) shall be valid; this being the maximum number of rooms supported by Digital Environ, LD90, EC90SV & CD80SV Dimmer Cabinets. Switch positions 1 - 9 only shall be valid for System 6 and the DN Interface. Each room shall have a maximum number of 12 channels of control.

10 All stations assigned to control a room will mimic the command actions from other stations within that room.

11 Digital Environ, LD90, EC90SV & CD80SV Dimmer Cabinets shall contain factory default preset levels and a single fade time for each preset for 16 rooms. System 6 and the Digital Network Interfaces shall have defaults for the 9 supported rooms only. It shall be possible to reset the current stored preset levels of all rooms to the default from the dimmer cabinet.

Default levels and fade times are as follows:

Preset 1	100%	Preset 2	85%	Preset 3	70%	Preset 4	60%
Preset 5	50%	Preset 6	40%	Preset 7	30%	Preset 8	20%

All presets have 5 second default fade times

OFF	0%	5 seconds	(time only programmable)
ON	100%	0 seconds	(non-programmable preset)
Manual Fade Time	0 seconds	(programmable 0-4 minutes)	

12 All control functions shall be governed by, and all programmed and stored intensity levels (presets) shall be resident in the dimmer cabinets or Digital Network Interface.

13 A Belden 9773 cable shall provide a communication and low voltage power path from the dimmer cabinet(s) or DN Interface and power supply, to the Outlook Stations. The number of stations, dimmer cabinets and DN Interfaces that can be connected to the common communications cable shall be limited to 32. The total cable length shall not exceed 1000ft (300m).

### OUTLOOK MASTER STATIONS

Specific features of the Outlook Master Stations are:-

1 3, 6, 9 or 12 channel sliders corresponding to the number of channels for control, with proportional master.

2 8 Pushbuttons, labelled 1 through 8, for recalling presets stored in the dimmer electronics or DN interface. The presets shall have factory default levels but can be re-programmed and recorded from the channel sliders or from Display Stations. Each preset shall have its own programmable fade time.

Selecting an active preset button shall cause the channels within the room to fade to the Off preset.

3 The Master slider shall be used for setting the fade time between 0 and 4 minutes which can be recorded into a preset.

The time scaling of the Master slider shall be:-

0 - 1 minute for 0 - 80 % of the scale and 1 - 4 minutes for 80 - 100 %

4 Each station shall have a "Manual" button for activating the sliders for level setting and taking control away from other stations within the same room.

Note: If there are more channels in a room than sliders on the station, then channels not directly under slider control shall not change level.

Each room shall have a programmable Manual Fade Time between 0 and 4 minutes to fade the lighting from the current level to the local slider settings when Manual is selected.

5 Each station shall have an "Enter" button for recording lighting levels into a selected preset 1 - 8 for later pushbutton recall, and for recording preset and manual fade times.

Each station shall have an Off button where the channels fade to off in a programmable fade time. If it is not programmed it shall default to a fade time of 5 seconds.

Outlook Master Stations shall support the following additional features implemented through a defined pushbutton sequence:-

1 **Record Lockout** - (Playback only operation) - Shall prevent unauthorized alteration to pre-recorded presets and fade times.

2 **Total Lockout** - Shall prevent unauthorized modification to current lighting levels from other station(s) within a room. Stations shall continue to mimic status of their assigned room.

All Room Combine stations and Room Combine Interfaces shall be unaffected by this lockout function.

3 **Preset Mastering** - The Master slider shall proportionally master a preset selected from the local station.

4 **Record Blind** - Shall set up and record a preset lighting state from the manual slider settings without modifying the current lighting levels.

### OUTLOOK REMOTE STATIONS

Specific features of the Outlook Remote Stations shall be:

1 1, 4 or 8 preset pushbuttons for recall of pre-programmed lighting scenes within a room.

2 Re-selecting a currently active preset shall cause the channels within the room to fade to Off in a programmable fade time.

### OUTLOOK DISPLAY STATIONS

Specific features of the Outlook Display Station shall be as follows:

1 The Display Station shall have a 16 line, 16 character backlit LCD display.

2 The LCD display shall label the current function assignments of 8 adjacent pushbuttons used typically for selecting presets, channels, rooms, or other specific menu functions.

3 It shall be possible to program preset, channel and room labels from the Display Station. Labels shall be locally held in the stations non volatile memory allowing alternative labels to be created for the same button function at each station.

A menu option shall enable the custom labels to be reset to factory defaults when required.

4 A PC based software utility enables the custom labels to be created and downloaded into the station via an RS485 link. It is expected that this function be carried out by a Commissioning Engineer.

5 A "Set-up" or "Configuration" menu shall be used to select one of two modes of operation during installation:

#### 1 Preset Recall Operation

In the Preset Recall mode of operation there shall be 5 basic menu screens:

Label Editing

1 Via the Label Editing menu up to 12 channels and 8 presets in the room to be controlled by the station can be assigned 9 and 11 character labels respectively. A "Clone" facility shall copy the labels to other Display Stations controlling the same room, to minimise programming.

Preset Recall

1 8 Labelled pushbuttons enable 8 presets stored in the dimmer electronics or Digital Network Interface to be recalled.

The presets shall have factory default levels but can be re-programmed and recorded from Display Station menu options or from Outlook Master Stations. Each preset shall have its own programmable fade time.

2 Raise and Lower buttons shall provide proportional mastering of the current preset, with the percentage level displayed on the LCD.

3 Each station shall have an Off button where the channels fade to off in a programmable fade time.

4 The Preset Recall Menu of Display Stations set to address the same room shall mimic each other.

5 Display Stations shall support the following additional features implemented through a defined pushbutton sequence:-

Record Lockout - to prevent local unauthorised modification of presets.

Total Lockout - for disabling all other stations within the same room to prevent changes to the lighting.

Level Setting (or "Manual")

1 Via the "Set-up" or "Configuration" menu, the number of channels to be displayed by the Level Setting menu shall be defined in the range 1 to 12.

2 Up to 7 labelled channels shall be displayed at any one time on the LCD. A Page+/- button shall scroll the display as required.

3 Entering the Level Setting Menu simulates selecting "Manual" at an Outlook Master or Slider station. Control is taken away from other stations within the same room and channels fade from their current level to the last known "Manual" levels, in a programmable fade time. The channel levels shall be displayed as a percentage adjacent to the channel label.

4 Channels shall be selected and levels modified using Raise and Lower buttons prior to recording the resulting "look" as a preset.

Record Menu

1 Via the Record Menu, it shall be possible to record the current lighting levels as a preset in the range 1 - 8, selected using the Raise and Lower scroll buttons.

2 It shall be possible to lockout access to the Record Menu from either the Preset Recall or Set-up Menu.

**Outlook™ Specifications****Fade Times**

1 It shall be possible to program a fade time of up to 4 minutes for each preset 1 - 8, Off and the fade to the Level Setting or "Manual" Menu. Fades shall be programmed with a 0.1 second resolution.

**2 Room Combine Operation**

In the Room Combine mode of operation there shall be 2 basic menu screens:

**Label Editing**

1 Via the Label Editing menu, 11 character labels shall be programmed for up to 16 rooms. A "Clone" facility shall copy the labels to other Display Stations operating in Room Combination mode to minimise programming.

**Link Status**

1 Via the "Set-up" or "Configuration" menu, the first and subsequent range of rooms to be displayed shall be defined. Thus it shall be possible to assign different Display Stations to perform room combine functions for different groups of rooms.

2 Up to 8 labelled rooms shall be displayed at any one time on the LCD. Scroll Up and Down buttons shall scroll the display as required to access all possible 16 rooms.

3 From the LCD pushbuttons it shall be possible to combine, cancel and preview room combinations. Stations shall provide a visual indication at all times of the existing room combination within the scope of their room display range.

4 When rooms are combined, all stations that are assigned to those rooms shall control lighting in the combined area.

5 Display Stations that are set to address the same rooms shall mimic each other.

6 Multiple room combinations shall be possible from any number of Room Combine Panels or Display Stations. A room shall only be part of one group at any one time.

**OUTLOOK SLIDER STATIONS**

Specific features of the Outlook Slider Stations shall be:-

1 3, 6, 9 or 12 Channel Sliders corresponding to the number of channels for control.

2 Each station shall have an Off button where the channels fade to off in a programmable fade time.

If it is not programmed it shall default to a fade time of 5 seconds.

3 Each station shall have a "Manual" button for activating the sliders for level setting and taking control away from other stations within the same room.

Note: If there are more channels in a room than sliders on the station, then channels not directly under slider control shall not change level.

Each room shall have a programmable Manual Fade Time between 0 and 4 minutes to fade the lighting from the current level to the local slider settings when Manual is selected.

4 Each station shall have an On button. On represents a non-programmable preset with instant fade time which shall switch all lights in the room to full intensity.

**OUTLOOK RECEPTACLE STATION**

Specific features of the Receptacle Station shall be:

1 The receptacle Station shall have a communications-quality 5-pin XLR socket for connecting a portable station.

2 A 16 position rotary switch shall be provided on the back of the Receptacle Station to select the room to be controlled by the portable station irrespective of the portable stations switch setting. A Receptacle Station shall be room specific.

**OUTLOOK INFRA RED TRANSMITTER AND RECEIVER**

Specific features of the Transmitter and Receiver shall be:-

1 The Infra Red Transmitter shall be battery operated and shall transmit data up to a distance of 50ft (15m).

2 The Infra Red Transmitter shall recall presets 1 - 7 and Off within a room. A single LED indicator shall flash while a button is pressed.

3 The Infra Red Receiver shall have a rotary switch to select the room to be controlled when valid signals are received from a Transmitter. A Receiver Station shall be room specific.

**OUTLOOK AUDIO VISUAL INTERFACE**

Specific features of the A/V Interface shall be:

1 The A/V Interface shall have a 16 position rotary switch to select the room to be controlled.

2 The Interface shall have 11 inputs that accept external contact closures to select 8 presets, Off, On and the Total Lockout function within a room. The input-assignments shall be:

Inputs 1 - 8	Lighting Presets	(momentary contact)
Input 9	Off	(momentary contact)
Input 10	On	(momentary contact)
Input 11	Total Lockout	(maintained contact)

3 Each input shall have an associated mimic output which can be used to drive an LED indicator.

4 An external 18-24 volt dc power supply shall be required for the A/V Interface.

5 An A/V Interface shall mimic commands from other Outlook Control Stations assigned to the same room.

**OUTLOOK ROOM COMBINE STATION**

1 Room Combine Stations shall be available in 3 standard variants:-  
1, 3 and 8 pushbuttons for combining 2, 3 or 8 rooms respectively.

2 The first button on a station shall represent the room whose number is set on the 16 position rotary switch on the reverse of the station. Any subsequent buttons shall follow on, in ascending numerical order.

3 A single pushbutton Room Combine Station shall, with a toggle action, combine the rooms set by the 16 position rotary switch on the reverse of the station. The pushbutton LED shall show the combine status.

4 3 and 8 pushbutton Room Combine Stations shall provide a visual indication at all times of the existing room combinations within the scope of their address range. Stations shall support room Combine, Cancel and Preview functions.

5 When rooms are combined, all stations that are assigned to those rooms shall control lighting in the combined area.

6 Room Combine panels that are set to address the same rooms shall mimic each other.

7 Multiple room combinations shall be possible from any number of Room Combine Panels. A room shall only be part of one group at any one time.

**OUTLOOK ROOM COMBINE INTERFACE**

1 The Room Combine Interface shall have 16 assigned inputs corresponding to Rooms 1 through 16.

This interface shall be used when non-standard configurations are required.

2 A switch selection shall determine one of two modes of operation:

**A** As a custom room combine panel. The assigned inputs shall accept momentary "dry contact" closures to manually perform room Combine, Cancel and Preview functions.

1 Each input shall have an associated mimic output which can be used to drive an LED indicator.

2 The Room Combine Interface shall mimic commands from other Room Combine Stations and Interfaces.

**B** As an interface for partition switches. Inputs connected together via a maintained contact closure shall automatically combine those associated rooms.

1 In this mode of operation, only one group of combined rooms shall be possible at any one time from a single Room Combine Interface.

2 No visual indication of combinations shall be provided.

3 An external 18-24 volt dc power supply is required for the Room Combine Interface.

**CABLE SPECIFICATION**

Interconnection between all Outlook Stations, Dimmer Cabinets & DN Interfaces shall be:-  
Belden 9773 3 Twisted pairs each individually shielded.

Conductors	#18 AWG
Nominal conductor resistance:	21.0 Ω/Km
Nominal shield resistance:	27.2 Ω/Km
Capacitance between conductors:	98 pF per metre
Maximum Cable Run:	1000ft (300 m) in total

**POWER SUPPLY**

Outlook Stations require an external 24 volt dc power supply which can either be a self contained unit for mounting in a dimmer/distribution room, or, depending on the type of dimmer used, this supply may be derived from the dimming system.

Refer to Data Sheets on dimming products for further information.

The Microcontrol/Outlook Power Supply listed under "Ordering Information" can support up to 20 Outlook Stations, and is supplied complete in an enclosure for wall mounting in the dimmer/distribution room. It is suitable for 90 - 240 volts ac 60 or 50 Hz supplies.

Power Supply Catalog No. 66101 is for DIN rail mounting within LD90 and supports up to 8 Outlook control stations. Power supplies 76462 and 76421 are for mounting within CD805V and EC905V Dimmer Cabinets respectively and support up to 20 Outlook control stations.

**DOCUMENTATION**

A Pocket Programming Guide (Part No.85005) shall be supplied with each system. Project installation and connection drawings shall be supplied as specified.

**SAFETY**

Outlook Control Stations operate at 24 volt safe extra low voltage circuits (SELV) and contain no hazardous voltages.

**ENVIRONMENTAL SPECIFICATION**

For all Outlook Control Stations and associated equipment, including dimmers and power supply units, the following recommendations shall apply:-

Ambient temperature extremes	32° - 104° F (0° - 40° C)
Relative humidity	10% - 90% non-condensing
General conditions	Office level cleanliness - Interior use only.

**Faceplate Sizes**

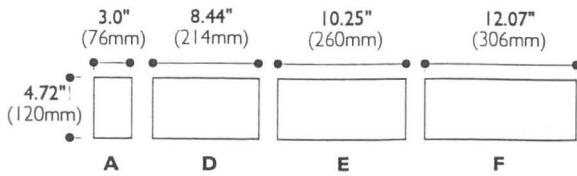

**Faceplate Side Detail**

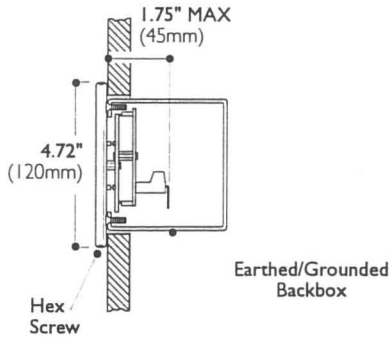

**Supplementary Power Supply Unit (Cat. No. 66100)**

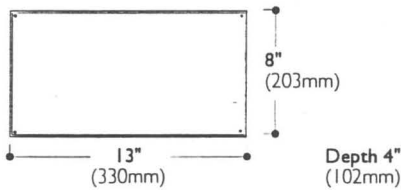

**Back Box Sizes**

All masonry back boxes are 3.5" (89mm) deep and all are 3.75" (95.3mm) high.

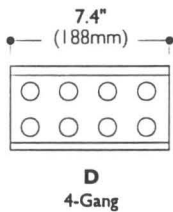

- A\* 1-Gang 1.97" (50mm)
- D 4-Gang 7.4" (188mm)
- E 5-Gang 9.22" (234mm)
- F 6-Gang 11.03" (280mm)

\* Note: Back boxes are subject to regional supply variations. Dimensions given are for guidance only and refer to Raco 690/960 series. Refer to your local Strand Representative for further details.

- Stations supplied with back box to order only.
- Bronze tinted Plexiglass locking covers are available to order for all Outlook Stations.
- Portable Enclosure kits enable standard stations to be converted to portable units. Kits are supplied complete with 25ft (8m) cable and mating connectors.

**Ordering Information**

Cat. No.	Faceplate/Back Box	Description
63003	D	Outlook – 3 Channel Master Station
63006	D	Outlook – 6 Channel Master Station
63009	E	Outlook – 9 Channel Master Station
63012	F	Outlook – 12 Channel Master Station
63030	D	Outlook – Display Station
63021	A	Outlook – 1 Preset Remote Station
63024	A	Outlook – 4 Preset Remote Station
63028	A	Outlook – 8 Preset Remote Station
63103	D	Outlook – 3 Channel Slider Station
63106	D	Outlook – 6 Channel Slider Station
63109	E	Outlook – 9 Channel Slider Station
63112	F	Outlook – 12 Channel Slider Station
63041	A	Outlook – Receptacle Station
63042	-	Outlook – Infra-red Transmitter
63043	A	Outlook – Infra-red Receiver
63044	-	Outlook – Audio Visual Interface (excludes back box or custom enclosure)
63031	A	Outlook – 2 Room Combine Station
63033	A	Outlook – 3 Room Combine Station
63038	A	Outlook – 8 Room Combine Station
63039	-	Outlook – Room Combine Interface (excludes back box or custom enclosure)
66100	-	Outlook/Microcontrol Power Supply with Enclosure
66101	-	Outlook (DIN Rail) Power Supply (LD90)
76462	-	Outlook Power Supply (CD805V)
76421	-	Outlook Power Supply (EC905V)
66711	-	Portable Enclosure kit (A-size)
66714	-	Portable Enclosure kit (D-size)
66715	-	Portable Enclosure kit (E-size)
66716	-	Portable Enclosure kit (F-size)
66800	-	1-Gang Masonry Back Box (A-size)
66804	-	4-Gang Masonry Back Box (D-size)
66805	-	5-Gang Masonry Back Box (E-size)
66806	-	6-Gang Masonry Back Box (F-size)
63040	-	Digital Network Interface

The Company reserves the right to make any variation in design or construction to the equipment described. © Strand Lighting Ltd 1995. Strand™, Strand Lighting™, Outlook™, Digital Environ™ LD90™, CD805V™, EC905V™ and Digital Network Interface™ are trade marks of Strand Lighting Limited and Strand Lighting Inc. Strand Lighting is a company within the Film & Television Division of The Rank Organisation Plc, United Kingdom. Country of origin United Kingdom.



- London:** Strand Lighting Ltd, Grant Way, Isleworth, Middlesex, TW7 5QD, United Kingdom. Tel: +44 (0)181 560 3171 Fax: +44 (0)181 568 2103
- Wolfenbüttel:** Strand Lighting GmbH, Salzbergstraße 2, 38302 Wolfenbüttel, Germany. Tel: +49 (0) 5331 3008-8 Fax: +49 (0) 5331 78883
- Rome:** Strand Lighting Srl, Via delle Gardenie 33, Pontina Vecchia Km 33,400, 00040 Pomezia-Roma, Italy. Tel: +39 (0) 6 914 7123 Fax: +39 (0) 6 914 7136
- Brussels:** Strand Lighting Ltd, Chaussée de Haecht 1801, 1130 Bruxelles, Belgium. Tel: +32 (0) 2 245 8686 Fax: +32 (0) 2 245 2235
- Stockholm:** Strand Lighting Ltd, Box 20105, Tappvägen 24, 161 02 Bromma, Sweden. Tel: +46 (0) 8 799 6950 Fax: +46 (0) 8 799 6954

ALSO FACILITIES IN: **LOS ANGELES • NEW YORK • HONG KONG • MILANO • MUNICH • BERLIN**