



Strand Lighting

P R O D U C T D A T A

Arturo 575W HMI DE Daylight Softlight

Arturo 575W HMI provides virtually shadow-less diffused illumination with daylight colour temperature. An optional eggcrate accessory may be fitted when directional limitation of the beam spread is required. Supplied complete with colour frame, and 7m cable to the ballast.

☑ 575W ☑ 110-240V* ☐ 53° x 89° 11kg
 ✱ 900 Lux ◀ 3m ✕ 222 x 400mm 16kg
 0.146m³ ✓ EN60 598 2-17

Cat. No. Description

24220 Arturo 575 HMI

Arturo 575 HMI DE Accessories

Cat. No. Description

42301	575W HMI double-ended lamp
25220	Compact magnetic ballast, 575W
25120	Electronic ballast, 575W
28201	Extension cable 575W, 8m
28202	Extension cable 575W, 15m
28310	Eggcrate, narrow
28311	Eggcrate, standard
28312	Additional colour frame
81011	Hercules stand, black, with castors
81022	Atlas stand
82012	Hook clamp to accept 29mm spigot (50mmØ barrel)
82013	Hook clamp to accept 29mm spigot (32-62mmØ barrel)

Arturo 1200W HMI DE Daylight Softlight

The mid-range Arturo 1200W HMI offers a powerful source of daylight fill from a compact lightweight head with a power consumption of only 6.4A. An optional eggcrate accessory may be fitted when directional limitation of the beam spread is required. Supplied complete with colour frame, and 7m cable to the ballast.

☑ 1200W ☑ 110-240V* ☐ 78° x 90° 16kg
 ✱ 860 Lux ◀ 5m ✕ 310mm x 510mm 22kg
 0.28m³ ✓ EN60 598 2-17

Cat. No. Description

24230 Arturo 1200 HMI

* depending on ballast used

Arturo 1200W HMI DE Accessories

Cat. No. Description

42302	1200W HMI double-ended lamp
25230	Compact magnetic ballast 1.2kW
25130	Electronic ballast, 1.2kW
25040	Electronic ballast, wattage dual 1.2kW/2.5kW
28203	Extension cable 1200V, 8m
28204	Extension cable 1200V, 15m
28314	Eggcrate, narrow
28315	Eggcrate, standard
28316	Additional colour frame
81011	Hercules stand, black, with castors
81022	Atlas stand
82012	Hook clamp to accept 29mm spigot (50mmØ barrel)
82013	Hook clamp to accept 29mm spigot (32-62mmØ barrel)

Arturo 2500W HMI DE Daylight Softlight

The Arturo 2500W HMI is the most powerful source of soft daylight illumination in the Arturo range. An optional eggcrate accessory may be fitted when directional limitation of the beam spread is required. Supplied complete with colour frame, and 7m cable to the ballast.

2500W ☑ 110-240V* ☐ 60° x 97° 20kg
 ✱ 2600 Lux ◀ 5m ✕ 410mm x 600mm 26kg
 0.39m³ ✓ EN60 598 2-17

Cat. No. Description

24240 Arturo 2500 HMI, head only

Arturo 2500 HMI DE Accessories

Cat. No. Description

42303	2500W HMI double-ended lamp
25240	Compact magnetic ballast, 2.5kW
25140	Electronic ballast, 2.5kW
25040	Electronic ballast, dual wattage 2.5kW/1.2kW
28205	Extension cable 2.5kW, 8m
28206	Extension cable 2.5kW, 15m
28316	Egg crate, narrow
28317	Egg crate, standard
28318	Additional colour frame
81011	Hercules stand, black, with castors
81022	Atlas stand
81015	Goliath stand, black
82012	Hook clamp to accept 29mm spigot (50mmØ barrel)
82013	Hook clamp to accept 29mm spigot (32-62mmØ barrel)

2.8.2

S O F T L I G H T S

ARTURO™ DAYLIGHT 575W, 1200W, 2500W

Arturo 575W HMI

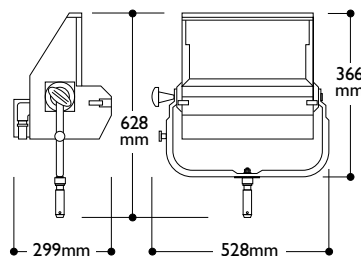

Arturo 1200W HMI

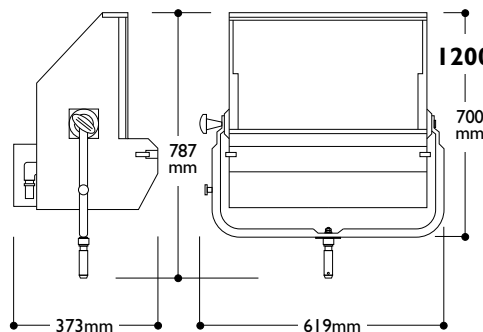

Arturo 2500W HMI

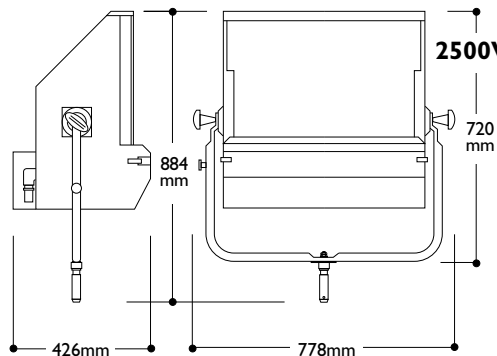

- Range of three double-ended HMI daylight softlights
- Designed for location fill lighting
- Daylight matching colour temperature maintained by the use of specially textured reflectors
- Asymmetric beam distribution for constant illumination as a subject walks towards the source
- Head incorporates UV safety glass with microswitch safety cut off
- Hour counter included to monitor lamp life
- Head mounted illuminated push buttons allow operation from head or ballast
- Can operate from compact magnetic or flicker free electronic ballasts
- Stirrup fitted with 29mm spigot

A GUIDE TO SYMBOLS AND ABBREVIATIONS

GENERAL ☑ Supply voltage ⚖ Weight of product 📦 Packed weight 📦 Packed volume
 ■ Overall dimension of product ✓ Compliance with international standards. ⚡ Watts (maximum recommended) ☐ Beam angle ◀ Throw (usual working distance from subject in metres) ✱ Illuminance (maximum Lux at throw distance stated with lamp recommended or supplied) ✕ Colour filter cut size
 DE Double-ended IP International Protection Standard

Photometric Data**Arturo 575W**

575W HMI/DE lamp (without eggcrate)

Throw (metres)	2		3		4		5	
	Lux	Ø	Lux	Ø	Lux	Ø	Lux	Ø
Intensity	2025		900		506		324	
Vertical (53°)		1.99		2.99		3.98		4.98
Horizontal (89°)		3.93		5.89		7.86		9.82

Performance at any distance $8100 \div \text{Distance}^2$ (without eggcrate)**Arturo 1200W**

1200W HMI/DE 1200W lamp (without eggcrate)

Throw (metres)	4		5		6		7	
	Lux	Ø	Lux	Ø	Lux	Ø	Lux	Ø
Intensity	1344		860		597		438	
Vertical (78°)		6.47		8.09		9.71		11.3
Horizontal (90°)		8.0		10.0		12.0		14.0

Performance at any distance $21500 \div \text{Distance}^2$ (without eggcrate)**Arturo 2500W**

2500W HMI/DE lamp (without eggcrate)

Throw (metres)	6		7		8		9		10	
	Lux	Ø	Lux	Ø	Lux	Ø	Lux	Ø	Lux	Ø
Intensity	1805		1326		1015		802		650	
Vertical (60°)		6.9		8.05		9.23		10.39		11.54
Horizontal (97°)		13.56		15.82		18.08		20.34		22.6

Performance at any distance $65000 \div \text{Distance}^2$ (without eggcrate)

Ø Vertical or horizontal spread in metres

Lamp Data

Specify lamps for replacement to the following specifications

	575W	1200W	2500W
Watts	575W	1200W	2500W
Designation	HMI/DE	HMI/DE	HMI/DE
Base	Screw fitting M4 x 10mm	Screw fitting M6 x 15.5mm	Tubular fitting 12mm x 21mm
Lumens	49000	110000	240000
Rated Life-Hours	750	750	500
Colour Temp	5600K	5600K	5600K

Electrical Data

Supply Voltage	110V to 240V 50/60Hz with appropriate ballast.
Max Lamp Watts	As designated by unit wattage.
Switching	Pushbutton switching from head or ballast with red and green illumination indicating status.
Cable/connections	7.5m integral head cable. 7 pin military specification bayonet connectors 575W & 1200W – 7 x 1.5mm ² 2500W – 3 x 4mm ² and 4 x 1mm ² .
Ballast	See separate data sheet.
Standards Compliance	EN60 598 2-17.

Environmental Data

Max Operating Ambient Temp	45°C.
IP Rating	IP20.
Tilt/Recommended angles of use	60° - 0 - 60°.

Mechanical Data

Paint/Finish	Black powder coated epoxy paint.
Lamp House	The housing is constructed from riveted sheet steel, specially shaped for robustness.
Reflectors	Primary and secondary reflectors in textured anodised aluminium. Side reflectors in polished anodised aluminium.
Mounting /Suspension	Tubular steel stirrup assembly with 29mm spigot for stand mounting.

Weight & Dimensions

	575W	1200W	2500W
Weight	11kg	16kg	20kg
Depth	299mm	373mm	426mm
Width	528mm	619mm	778mm
Height	628mm	787mm	884mm
Accessory size	220 x 400mm	310 x 510mm	410 x 600mm

Operational Data

Lamp Access	Through hinge-down cover to expose lamp trays and lampholders. Secured by toggle catches and with microswitch safety cut off.
Beam Adjustment	Horizontal and vertical beam control can be achieved by means of standard and narrow eggcrate accessories.
Tilt Adjustment	Tilt angle is set by heat insulated lock handle.
Accessory fitting	Eggcrates and colour frames are inserted into vertical runners and retained by hinging top lid.

**Strand Lighting**

London: Strand Lighting Ltd, Grant Way, Isleworth, Middlesex, TW7 5QD, United Kingdom.
Tel: +44 (0)181 560 3171 Fax: +44 (0)181 568 2103

Wolfenbüttel: Strand Lighting GmbH, Salzbergstraße 2, 38302 Wolfenbüttel, Germany.
Tel: +49 (0) 5331 3008-8 Fax: +49 (0) 5331 78883

Rome: Strand Lighting Srl, Via delle Gardenie 33, Pontina Vecchia Km 33,400, 00040 Pomezia-Roma, Italy
Tel: +39 (0) 6 914 7123 Fax: +39 (0) 6 914 7136

Brussels: Strand Lighting Ltd, Chaussée de Haecht 1801, 1130 Bruxelles, Belgium
Tel: +32 (0) 2 245 8686 Fax: +32 (0) 2 245 2235

Stockholm: Strand Lighting Ltd, Box 20105, Tappvägen 24, 161 02 Bromma, Sweden
Tel: +46 (0) 8 799 6950 Fax: +46 (0) 8 799 6954

ALSO

FACILITIES IN: **LOS ANGELES • NEW YORK • HONG KONG • MILANO • MUNICH • BERLIN**

© Copyright Strand Lighting Limited October 1995

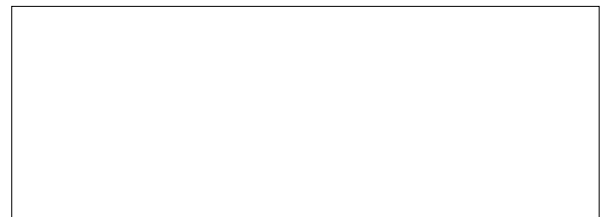

The Company reserves the right to make any variation in design or construction to the equipment described. Strand Lighting Ltd 1995. Arturo™ is a trade mark of Strand Lighting Limited. Strand Lighting is a company within the Film & Television Division of The Rank Organisation Plc, United Kingdom. Country of origin Italy.