



Strand Lighting

P R O D U C T D A T A

Arturo 1250W

Designed for the small studio or as a location fill light, Arturo 1250W provides virtually shadowless diffused illumination. The pole-operated version includes geared control of pan and tilt with friction clutches to allow for manual override. Optional eggcrate accessories may be fitted for directional control of the beam spread. Supplied complete with colour frame, and 3.5m power cable with in-line switch.

☑ 1250W ☑ 230/240V ☑ 62° x 95° ☑ 11kg
 ✱ 1200 Lux ◀ 3m ✕ 220mm x 400mm ☑ 15kg
 ☑ 0.118m³ ✓ EN60 598 2-17

Cat. No. Description

26500	Arturo 1250W, Manual Operation
26510	Arturo 1250W, Pole Operation

Arturo 1250W Accessories

Cat. No. Description

43104	P2/10, 625W 240V lamp
43103	P2/10, 625W 230V lamp
43074	P2/7, 1000W 240V lamp
43073	P2/7, 1000W 230V lamp
43124	P2/12, 1250W 240V lamp
43123	P2/10, 1250W 230V lamp
28310	Eggcrate, narrow
28311	Eggcrate, standard
28312	Additional colour frame
82002	Safety bond, 50kg
82012	Hook clamp to accept 29mm spigot (50mmØ barrel)
82013	Hook clamp to accept 29mm spigot (32-62mmØ barrel)
81011	Hercules stand, black, with castors
81022	Atlas with castors stand

Arturo 2500W

This Arturo is a 2.5kW dual power softlight with two lamps, switched individually, to give intensity control with constant colour temperature. Designed for 2 x 189mm linear tungsten halogen lamps of 1250W, 1000W or 625W. A three position rotary lamp allows switching between one lamp on, two on, or off. The pole-operated version includes geared control of pan and tilt with friction clutches to allow override. Optional eggcrate accessories may be fitted for directional control of beam spread. Supplied complete with colour frame and 7.0m of power cable.

☑ 2500W ☑ 230/240V ☑ 64° x 99° ☑ 14kg
 ✱ 1000 Lux ◀ 5m ✕ 310mm x 510mm ☑ 23kg
 ☑ 0.244m³ ✓ EN60 598 2-17

Cat. No. Description

26520	Arturo 1.25/2.5kW, Manual Operation
26530	Arturo 1.25/2.5kW, Pole Operation

Arturo 2500W Accessories

Cat. No. Description

43104	P2/10, 625W 240V lamp
43103	P2/10, 625W 230V lamp
43074	P2/7, 1000W 240V lamp
43073	P2/7, 1000W 230V lamp
43124	P2/12, 1250W 240V lamp
43123	P2/10, 1250W 230V lamp
28313	Eggcrate, narrow
28314	Eggcrate, standard
28315	Additional colour frame
82002	Safety bond, 50kg
82012	Hook clamp to accept 29mm spigot (50mmØ barrel)
82013	Hook clamp to accept 29mm spigot (32-62mmØ barrel)
81011	Hercules stand, black, with castors
81022	Atlas with castors stand

Arturo 5000W

This Arturo is a 5kW dual power softlight with four lamps, switched in pairs, to give intensity control with constant colour temperature. Designed for 4 x 189mm linear tungsten halogen lamps of 1250W, 1000W or 625W. A four position rotary switch allows lamp switching between one pair, two pairs, or off. The pole-operated version includes geared control of pan and tilt with friction clutches to allow override. Optional eggcrate accessories may be fitted for directional control of beam spread. Supplied complete with colour frame and 7.0m of power cable.

☑ 5000W ☑ 230/240V ☑ 68° x 105° ☑ 20.5kg
 ✱ 892 Lux ◀ 7m ✕ 410mm x 600mm ☑ 28kg
 ☑ 0.39m³ ✓ EN60 598 2-17

Cat. No. Description

26540	Arturo 2.5/5kW, Manual Operation
26550	Arturo 2.5/5kW, Pole Operation

Arturo 5000W Accessories

Cat. No. Description

43104	P2/10, 625W 240V lamp
43103	P2/10, 625W 230V lamp
43074	P2/7, 1000W 240V lamp
43073	P2/7, 1000W 230V lamp
43124	P2/12, 1250W 240V lamp
43123	P2/10, 1250W 230V lamp
28316	Eggcrate, narrow
28317	Eggcrate, standard
28318	Additional colour frame
82002	Safety bond, 50kg
82012	Hook clamp to accept 29mm spigot (50mmØ barrel)
82013	Hook clamp to accept 29mm spigot (32-62mmØ barrel)
81011	Hercules stand, black, with castors
81022	Atlas with castors stand
81015	Goliath stand, black

2.3.4

S O F T L I G H T S

ARTURO™ Softlights 1250W, 2500W & 5000W

Arturo
1250W

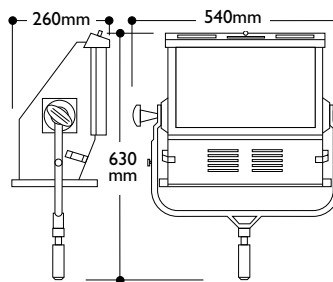

Arturo
2500W

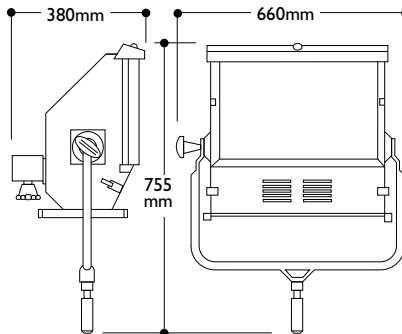

Arturo
5000W

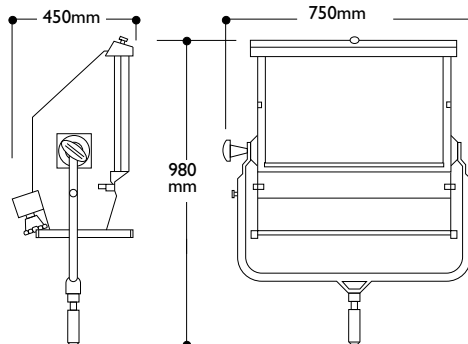

- A range of three tungsten halogen studio softlights for 1250W, 2500W and 5000W operation
- Accepts 189mm linear tungsten halogen lamps at 1250W, 1000W or 650W
- Suitable for studio and location
- Optical system ensures shadowless indirect fill light from secondary reflector design
- Asymmetric beam distribution gives constant illumination as a subject approaches the source
- Manual or Pole-operated versions available
- Lamp switching reduces intensity without a change of colour temperature on 2500W and 5kW models
- All units have easy access to lamps for replacement
- Supplied in black with colour/diffuser frame and stirrup with 29mm spigot
- Eggcrate accessories available for extra beam control

A GUIDE TO SYMBOLS AND ABBREVIATIONS

GENERAL ☑ Supply voltage ☑ Weight of product ☑ Packed weight ☑ Packed volume ☑ Overall dimension of product ✓ Compliance with international standards. ☑ Watts (maximum recommended) ☑ Beam angle ◀ Throw (usual working distance from subject in metres) ✱ Illuminance (maximum Lux at throw distance stated with lamp recommended or supplied) ✕ Colour filter cut size IP International Protection Standard

Photometric Data**Arturo 1250W** (without eggcrate)

Typical performance based on P2/12 1250W 230 or 240V lamp

Throw (metres)	2		3		4		5		6	
	Lux	Ø	Lux	Ø	Lux	Ø	Lux	Ø	Lux	Ø
Intensity	2700		1200		675		432		300	
Vertical		2.4		3.6		4.8		6.0		7.21
Horizontal		4.36		6.54		8.73		10.91		13.0

Arturo 2500W (without eggcrate)

Typical performance based on 2 x P2/12 1250W 230 or 240V lamp

Throw (metres)	4		5		6		7		8	
	Lux	Ø	Lux	Ø	Lux	Ø	Lux	Ø	Lux	Ø
Intensity	1562		1000		694		510		390	
Vertical		5.0		6.24		7.5		8.75		10.0
Horizontal		9.36		11.07		14.0		16.4		18.73

Arturo 5000W (without eggcrate)

Typical performance based on 4 x P2/12 1250W 230 or 240V lamp

Throw (metres)	6		7		8		9		10	
	Lux	Ø	Lux	Ø	Lux	Ø	Lux	Ø	Lux	Ø
Intensity	1216		892		683		540		437	
Vertical		8.09		9.44		10.79		12.14		13.5
Horizontal		15.83		18.24		20.85		23.45		26.0

Ø Vertical or horizontal spread in metres

Lamp Data

Specify lamps for replacement to the following specifications.

Watts	625W	1000W	1250W
Designation	P2/10	P2/7	P2/12
Base	R7s	R7s	R7s
Lumens	16900	26000	35000
Rated Life-Hours	200	200	200
Colour Temp.	3200K	3200K	3200K

Electrical Data

Supply Voltage	230V or 240V 50/60Hz
Max Lamp Watts	As designated for each compartment
Lamp Base/Socket	R7s
Switching and Cable	Arturo 1250W: 4m of 3 x 1.5mm ² cable with in-line switch. Arturo 2500W: 7m of 3 x 2.5mm ² cable head mounted rotary switch (three position 1-on, 2-on, off). Arturo 5000W: 7m of 3 x 4.0mm ² cable head mounted rotary switch (four position 1-pair, 2-pair [all-on], off).
Standards Compliance	EN60 598 2-17 GS approved

Environmental Data

Max Operating Ambient Temp	45°C
IP Rating	IP20
Tilt/Recommended angles of use	90° - 0 - 90°

Mechanical Data

Paint/Finish	Black powder coated epoxy paint.
Lamp House	The housing is constructed from riveted sheet steel, specially shaped for robustness.
Reflectors	Primary and secondary reflectors in textured anodised aluminium. Side reflectors in polished anodised aluminium.
Mounting/Suspension	Tubular steel stirrup assembly with 29mm spigot for stand mounting. PO version fitted with cast brass gear boxes with friction clutches for manual override, driven from standard Quartzcolor PO cups.

Weights and Dimensions

	1250MO	1250PO	2500MO	2500PO	5000MO	5000PO
Weight	10kg	11kg	12.4kg	14.0kg	20.0kg	24.0kg
Depth	260mm	260mm	380mm	380mm	450mm	450mm
Width	540mm	521mm	660mm	650mm	750mm	743mm
Height	630mm	585mm	755mm	700mm	980mm	930mm
Accessory size	220 x 400mm		310 x 510mm		410 x 600mm	

Operational Data

Lamp Access	Through hinge-down cover to expose lamp trays and lampholders. Secured by toggle catches.
Beam Adjustment	Horizontal and vertical beam control can be achieved by means of standard and narrow eggcrate accessories.
Tilt Adjustment	Tilt angle is set by heat insulated lock handle PO angle is set by operation of cup.
Accessory fitting	Eggcrates and colour frames are inserted into vertical runners and retained by hinging top lid.

**Strand Lighting**

London: Strand Lighting Ltd, Grant Way, Isleworth, Middlesex, TW7 5QD, United Kingdom.
Tel: +44 (0)181 560 3171 Fax: +44 (0)181 568 2103

Wolfenbüttel: Strand Lighting GmbH, Salzbergstraße 2, 38302 Wolfenbüttel, Germany.
Tel: +49 (0) 5331 3008-8 Fax: +49 (0) 5331 78883

Rome: Strand Lighting Srl, Via delle Gardenie 33, Pontina Vecchia Km 33,400, 00040 Pomezia-Roma, Italy
Tel: +39 (0) 6 914 7123 Fax: +39 (0) 6 914 7136

Brussels: Strand Lighting Ltd, Chaussée de Haecht 1801, 1130 Bruxelles, Belgium
Tel: +32 (0) 2 245 8686 Fax: +32 (0) 2 245 2235

Stockholm: Strand Lighting Ltd, Box 20105, Tappvågen 24, 161 02 Bromma, Sweden
Tel: +46 (0) 8 799 6950 Fax: +46 (0) 8 799 6954

ALSO FACILITIES IN: **LOS ANGELES • NEW YORK • HONG KONG • MILANO • MUNICH • BERLIN**

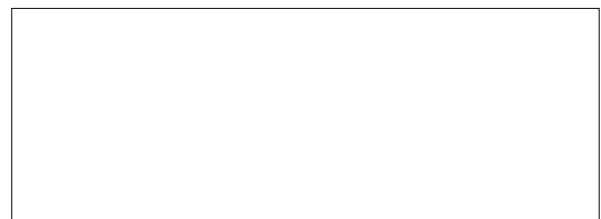

The Company reserves the right to make any variation in design or construction to the equipment described. © Strand Lighting Ltd 1995. Strand™, Strand Lighting™ and Arturo™ are trade marks of Strand Lighting Limited. Strand Lighting is a company within the Film & Television Division of The Rank Organisation Plc, United Kingdom. Country of origin Italy.