

SCALE 1: 10

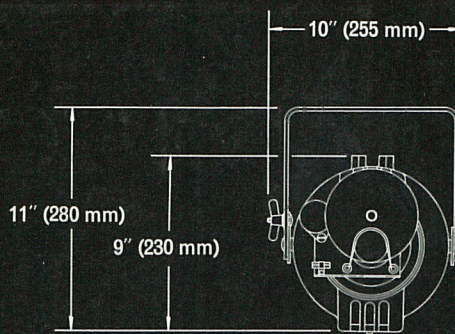

WEIGHT
Patt 202 series 15 \pm lb. (7 kilos)

SPECIFICATION

The effects spot shall be constructed of aluminium alloy die-castings with baffled ventilation slots and shall contain a built-in transformer, a miniature 2-pin lampholder, a spherical reflector and a condenser lens system incorporating a heat-absorbing glass.

The built-in double wound transformer for a 250-watt 24 volt tungsten-halogen projection lamp shall have an additional 1 watt 12 volt output, terminating in an external 2.5mm jack socket, for the motor drive of the effects disc. A hinged rear casting shall provide access to the transformer and to the internal terminal block which shall be fitted with 30-in. (0.75m) external length of 3-conductor sheathed cable secured by a strain-relief gland.

The whole optical assembly consisting of a 2-in. (50mm) diameter polished aluminium spherical reflector, a miniature 2-pin lampholder fitted with a heat-sink, and a condenser lens consisting of two 1 3/4-in. (45mm) diameter plano-convex lenses with a disc of heat-absorbing glass shall be mounted on a die-cast front which shall also incorporate runners for 2-in (50mm) square backplate effects attachments. Access to the lampholder and to all lens surfaces shall be by releasing two chrome toggle fasteners which normally secure the front casting to the main body of the lamphouse. The exterior and the interior of the lamphouse shall be finished matt black. The effects spot shall be mounted in a reversible cadmium plated mild steel fork fitted with a friction disc tilt clamp and provided with a 3/8-in. bolt and wing nut for suspension.

EFFECTS ATTACHMENT

Each effects spot shall be supplied with an effects attachment on a 2-in. square rotatable backplate. This attachment shall consist of a 12 volt motor rim-driving a 4 3/4-in.

(120mm) non-flammable effects disc and a pair of lens guide rods with spring clips for the two 1 3/4-in. (45mm) objective lenses supplied. The spring-tensioned motor drive shall be provided with a 9-in. (230mm) length of flexible cable terminating in a 2.5mm jack plug, for interconnection to the lamphouse, and an alternative drive wheel providing a 33% speed reduction. The type of effects disc supplied shall be as follows:-

Patt 202/K – with Kaleidospot colour disc, and set of six alternative break-up pattern discs with two mounting clips.

Patt 202/SC – with Storm Cloud disc.

Patt 202/FC – with Fleecy Cloud disc.

Patt 202/S – with Snow disc.

Patt 202/F – with Flame disc, special break-up disc and fast motor drive.

LAMP

250-watt 24 volt tungsten halogen.

ACCESSORIES

Ref. 367 6-in. (150mm) diameter die-cast ceiling or base plate.

Ref. 671 Colour filter holder.

CONVERSIONS

With the exception of the Flame effect, which is provided with a faster motor drive, effects discs are interchangeable.

Ref. 680 Kaleidospot colour disc and pattern glasses.

Ref. 681 Storm Cloud disc.

Ref. 682 Fleecy Cloud disc.

Ref. 683 Snow disc.